



City of Fort Bragg

416 N Franklin Street
Fort Bragg, CA 95437
Phone: (707) 961-2823
Fax: (707) 961-2802

Meeting Agenda City Council

**THE FORT BRAGG CITY COUNCIL MEETS CONCURRENTLY AS
THE FORT BRAGG MUNICIPAL IMPROVEMENT DISTRICT NO. 1
AND THE FORT BRAGG REDEVELOPMENT SUCCESSOR
AGENCY**

Monday, May 10, 2021

6:00 PM

Town Hall, 363 N. Main Street

CALL TO ORDER

PLEDGE OF ALLEGIANCE

ROLL CALL

PLEASE TAKE NOTICE

Tonight's City Council meeting is presented in a hybrid format, both in-person at Town Hall and virtually via Zoom. The Governor's Executive Orders N-25-20 and N-29-20 suspend certain requirements of the Brown Act, and City Councilmembers and staff may choose to participate in person or by video conference.

The meeting will be live-streamed on the City's website at <https://city.fortbragg.com/> and on Channel 3. Public comments regarding matters on the agenda may be made in person at Town Hall or by joining the Zoom video conference and using the Raise Hand feature when the Mayor or Acting Mayor calls for public comment. Any written public comments received after agenda publication will be forwarded to the Councilmembers as soon as possible after receipt. All comments on agenda matters will become a permanent part of the agenda packet on the day after the meeting or as soon thereafter as possible. Public comments may be submitted to City Clerk June Lemos at jlemos@fortbragg.com.

ZOOM WEBINAR INVITATION

*You are invited to a Zoom webinar.
When: May 10, 2021 06:00 PM Pacific Time (US and Canada)
Topic: City Council Meeting*

*Please click the link below to join the webinar:
<https://zoom.us/j/94257520821>
Or Telephone:*

*Dial (for higher quality, dial a number based on your current location): US: +1 669 900 9128
Webinar ID: 942 5752 0821*

TO SPEAK DURING PUBLIC COMMENT PORTIONS OF THE AGENDA VIA ZOOM, PLEASE JOIN THE MEETING AND USE THE RAISE HAND FEATURE WHEN THE MAYOR OR ACTING MAYOR CALLS FOR PUBLIC COMMENT ON THE ITEM YOU WISH TO ADDRESS.

AGENDA REVIEW

1. MAYOR'S RECOGNITIONS AND ANNOUNCEMENTS

- 1A. [21-159](#) Presentation by Tim Karas, Ed.D, President/Superintendent of Mendocino-Lake Community College District

Attachments: [Mendocion College PPT](#)

2. PUBLIC COMMENTS ON: (1) NON-AGENDA, (2) CONSENT CALENDAR & (3) CLOSED SESSION ITEMS

MANNER OF ADDRESSING THE CITY COUNCIL: All remarks and questions shall be addressed to the City Council; no discussion or action will be taken pursuant to the Brown Act. No person shall speak without being recognized by the Mayor or Acting Mayor. Public comments are restricted to three (3) minutes per speaker.

TIME ALLOTMENT FOR PUBLIC COMMENT ON NON-AGENDA ITEMS: Thirty (30) minutes shall be allotted to receiving public comments. If necessary, the Mayor or Acting Mayor may allot an additional 30 minutes to public comments after Conduct of Business to allow those who have not yet spoken to do so. Any citizen, after being recognized by the Mayor or Acting Mayor, may speak on any topic that may be a proper subject for discussion before the City Council for such period of time as the Mayor or Acting Mayor may determine is appropriate under the circumstances of the particular meeting, including number of persons wishing to speak or the complexity of a particular topic. Time limitations shall be set without regard to a speaker's point of view or the content of the speech, as long as the speaker's comments are not disruptive of the meeting.

BROWN ACT REQUIREMENTS: The Brown Act does not allow action or discussion on items not on the agenda (subject to narrow exceptions). This will limit the Council's response to questions and requests made during this comment period.

3. STAFF COMMENTS

4. MATTERS FROM COUNCILMEMBERS

5. CONSENT CALENDAR

All items under the Consent Calendar will be acted upon in one motion unless a Councilmember requests that an individual item be taken up under Conduct of Business.

- 5A. [21-209](#) Amend City Council Resolution 4365-2021 Approving a Professional Services Agreement with Parker Lucas & Associates DBA Community Development Services for Community Development Block Grant (CDBG) Funded Business Loan Services and Authorizing City Manager to Execute Same (Amount Not to Exceed \$105,774; Account No. 331-5035-0630)

Attachments: [RESO 4365-2021 \(as amended\)](#)
[RESO 4365-2021 \(as adopted\)](#)
[Community Development Services Contract](#)
[E&O Insurance Quote](#)

- 5B. [21-129](#) Adopt City Council Resolution Approving Parcel Map for Minor Division 1-20 (DIV 1-20); Carlos and Heather Franco (owner/applicant); Minor Subdivision of a 22,989 Square Foot Parcel Into Three Parcels of 7,515, 7,793, and 7,681 Square Feet and Accepting the 10 Foot Wide Public

Utility Easement as Shown on the Parcel Map

Attachments: [RESO Approve DIV 1-20](#)
[Parcel Map DIV 1-20](#)
[Easement and Maintenance Agreement](#)

- 5C. [21-183](#) Adopt City Council Resolution Authorizing the City Manager to Execute the Acceptance of an Offer of a 15-foot wide Public Right of Way dedication for South Sanderson Way from Robert L. Habekoss and Rosemary E. Habekoss

Attachments: [RESO Habekoss Right of Way](#)

- 5D. [21-208](#) Adopt City Council Resolution Approving an Increase in Compensation for Seasonal/Temporary Classifications and the Police Services Transporter Classification

Attachments: [RESO Approve Temp-Seasonal Classifications Wage Increase](#)

- 5E. [21-210](#) Adopt City Council Resolution Confirming the Continued Existence of a Local Emergency in the City of Fort Bragg

Attachments: [RESO Declaring Continuing Local Emergency](#)

- 5F. [21-213](#) Adopt City Council Resolution Cancelling the Regularly Scheduled City Council Meeting of August 23, 2021 to Accommodate Summer Vacation Schedules

Attachments: [RESO Cancelling August 23 Council Meeting](#)

- 5G. [21-206](#) Receive and File Minutes of the March 17, 2021 Special Public Safety Committee Meeting

Attachments: [PSCM Special 2021-03-17.pdf](#)

- 5H. [21-212](#) Approve Minutes of April 26, 2021

Attachments: [CCM2021-04-26](#)

- 5I. [21-218](#) Approve Minutes of Special Closed Session of April 30, 2021

Attachments: [CCM2021-04-30_Closed](#)

- 5J. [21-219](#) Approve Minutes of Special Meeting of May 3, 2021

Attachments: [CCM2021-05-03_Special](#)

- 5K. [21-223](#) Approve Minutes of Special Closed Session of May 4, 2021

Attachments: [CCM2021-05-04_Closed](#)

6. DISCLOSURE OF EX PARTE COMMUNICATIONS ON AGENDA ITEMS

7. PUBLIC HEARING

When a Public Hearing has been underway for a period of 60 minutes, the Council must vote on whether to continue with the hearing or to continue the hearing to another meeting.

8. CONDUCT OF BUSINESS

- 8A. [21-220](#)** Receive Report and Consider Introducing by Title Only and Waiving the First Reading of Ordinance 966-2021 Amending Chapter 9.30 (Cannabis Businesses) of Title 9 (Public Peace, Safety and Morals) of the Fort Bragg Municipal Code

Attachments: [05102021 Ordinance Amending Chapter 9.30](#)
[ATT 1- Proposed Ordinance on Cannabis Cultivation](#)
[Public Comment 8A](#)

- 8B. [21-217](#)** Receive Report and Consider Two Requests for a Waiver of the Fee to Appeal a Planning Commission Decision to the City Council

Attachments: [05102021 Appeal Fee Waiver](#)
[Att. 1 - Ferris Request](#)
[Public Comment 8B](#)

- 8C. [21-216](#)** Receive Report and Consider Adoption of Municipal Improvement District Resolution Approving Budget Amendment No. 2021-10 Adjusting Selected Expenditure and Revenue Budgets

Attachments: [05102021 Biosolids Dryer Staff Report](#)
[Att. 1 Resolution](#)
[Att. 2 Exhibit A Budget Amendments](#)
[Att. 3 Dryer Proposals](#)
[Att. 4 Sodium Hypochlorite quote](#)

- 8D. [21-225](#)** Receive Report and Consider Adoption of City Council Resolution Recommending and Encouraging Voluntary Implementation of Stage 1 Water Conservation Measures in Fort Bragg

Attachments: [05102021 Stage 1 Water Conservation Measures](#)
[Att 1 - RESO Voluntary Stage 1 Water Conservation](#)
[Att 2 - NoyoFlows](#)
[Public Comment 8D](#)

- 8E. [21-222](#)** City Council Report on Actions Following Adoption of Interim Urgency Ordinance Placing a 45-day Moratorium on the Approval of Applications and Permits for Formula Businesses in the Inland Zoning Area

Attachments: [05102021 Moratorium Council Report](#)
[Att 1 - Council Moratorium Report](#)

9. CLOSED SESSION

ADJOURNMENT

The adjournment time for all Council meetings is no later than 10:00 p.m. If the Council is still in session at 10:00 p.m., the Council may continue the meeting upon majority vote.

**NEXT REGULAR CITY COUNCIL MEETING:
6:00 P.M., MONDAY, MAY 24, 2021**

STATE OF CALIFORNIA)
)ss.
COUNTY OF MENDOCINO)

I declare, under penalty of perjury, that I am employed by the City of Fort Bragg and that I caused this agenda to be posted in the City Hall notice case on May 6, 2021.

June Lemos, CMC
City Clerk

NOTICE TO THE PUBLIC:

DISTRIBUTION OF ADDITIONAL INFORMATION FOLLOWING AGENDA PACKET DISTRIBUTION:

- *Materials related to an item on this Agenda submitted to the Council/District/Agency after distribution of the agenda packet are available for public inspection upon making reasonable arrangements with the City Clerk for viewing same during normal business hours.*
- *Such documents are also available on the City of Fort Bragg's website at <https://city.fortbragg.com> subject to staff's ability to post the documents before the meeting.*

ADA NOTICE AND HEARING IMPAIRED PROVISIONS:

It is the policy of the City of Fort Bragg to offer its public programs, services and meetings in a manner that is readily accessible to everyone, including those with disabilities. Upon request, this agenda will be made available in appropriate alternative formats to persons with disabilities.

If you need assistance to ensure your full participation, please contact the City Clerk at (707) 961-2823. Notification 48 hours in advance of any need for assistance will enable the City to make reasonable arrangements to ensure accessibility.

This notice is in compliance with the Americans with Disabilities Act (28 CFR, 35.102-35.104 ADA Title II).



City of Fort Bragg

416 N Franklin Street
Fort Bragg, CA 95437
Phone: (707) 961-2823
Fax: (707) 961-2802

Text File

File Number: 21-159

Agenda Date: 5/10/2021

Version: 1

Status: Mayor's Office

In Control: City Council

File Type: Report

Agenda Number: 1A.

Presentation by Tim Karas, Ed.D, President/Superintendent of Mendocino-Lake Community College District



MENDOCINO
COLLEGE

Tim Karas, Ed.D

**Superintendent/President
Fort Bragg City Council Presentation
May 10, 2021**

PHILOSOPHY

Personal philosophy — to remain “student-centered, faculty- and staff-focused, and community-minded”

Educational philosophy- community colleges are agents of positive change to strengthen our democratic and civil society. We are the engines of economic and social mobility. We ensure higher education is a right for all, not only a privileged few.

BACKGROUND



- Mission College
Director, Library Services
Dean, Language Arts & Liberal Studies
- College of Alameda
Vice-President, Instruction
President
- Mendocino College
Superintendent/President



- West Valley College
- University of Hawaii
- Humboldt State University
- San Jose State University
- Boise State University
- Exeter University, UK
- Fielding Graduate University



- Born and raised in San Jose, CA
- Mother from Germany
- **Father from Greece**
- Partner, John



- San Francisco Bay Area/Silicon Valley
- Eureka, CA
- Boise, ID
- Honolulu, HI

MENDOCINO COLLEGE

FOUR LOCATIONS

Main Campus- Ukiah



North County Center- Willits



Lake Center- Lakeport



Coast Center- Fort Bragg



Coast Center- Fort Bragg

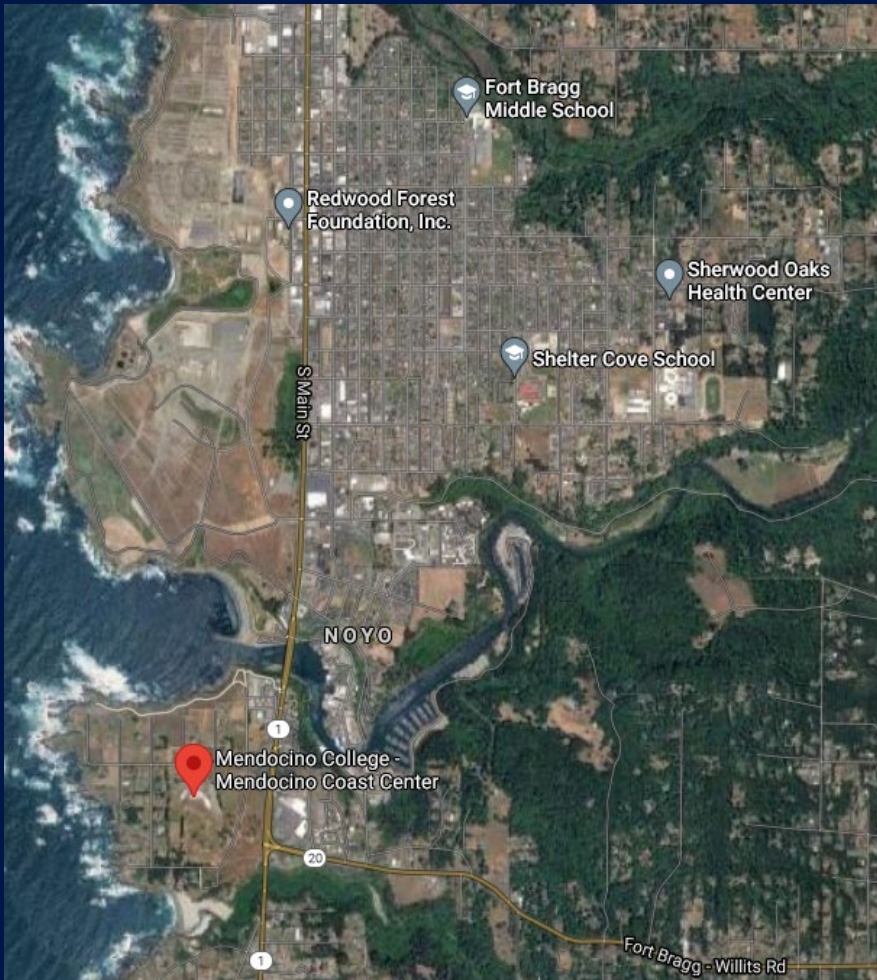

The Coast Center, located at 1211 Del mar Drive, is comprised of four separate buildings on an 11 acre campus, was built by the College of the Redwoods in 1987 with a second build out in 1996 for the 300 buildings. Total square footage of the center is approximately 25,000 sqft.

In 2017, MLCCD renovated the existing library, removing many fixed shelves and furniture in order to more open the space and invite student collaboration.

Fine Wood Working, located at 440 Alger Street and miles away from the Coast Center, was built in 1982, and is approximately 4,700 sqft.

Student Data

SPRING 2020 ENROLLMENT DATA



SPRING 2020 ENROLLMENT

4,050

CENSUS DAY

Students by Residence

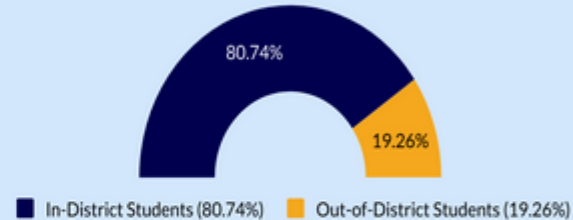

In-District Students

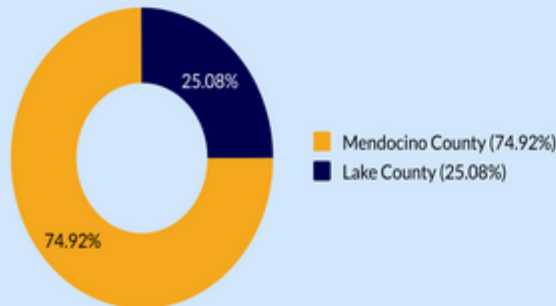

Admission Status

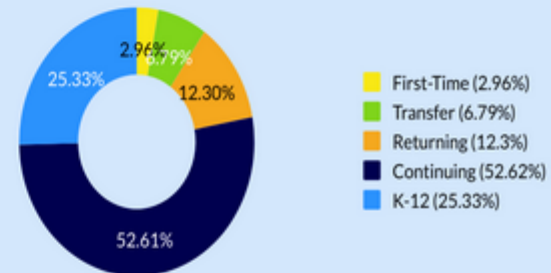

Enrollment by Location

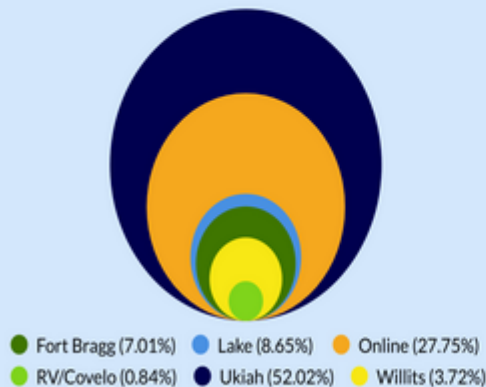

Enrollment Status

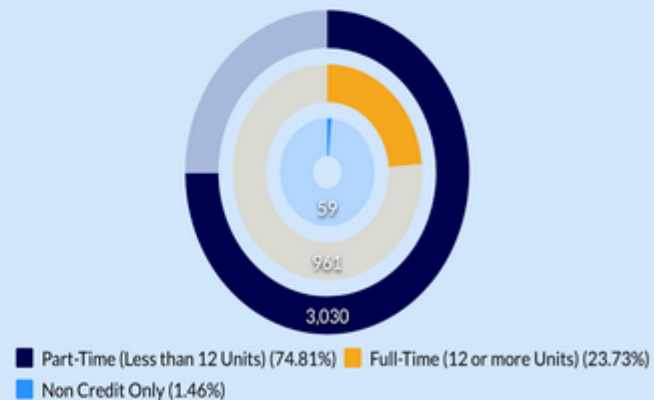

SPRING 2020 STUDENT DEMOGRAPHICS

Ethnicity



■ Native American (4.52%)
 ■ Asian (2.93%)
 ■ Black (1.8%)
■ Hispanic (37.57%)
 ■ Pacific Islander (0.22%)
■ White (50.04%)
 ■ Multi-Ethnic (1.47%)
 ■ Unknown (1.47%)

Gender



■ Female (63%)
■ Male (37%)

Student Age

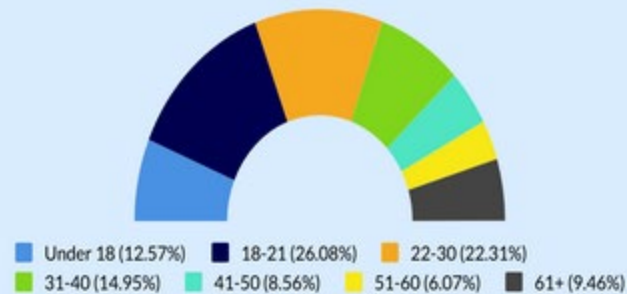

■ Under 18 (12.57%)
 ■ 18-21 (26.08%)
 ■ 22-30 (22.31%)
■ 31-40 (14.95%)
 ■ 41-50 (8.56%)
 ■ 51-60 (6.07%)
 ■ 61+ (9.46%)

2019-2020 AWARDS

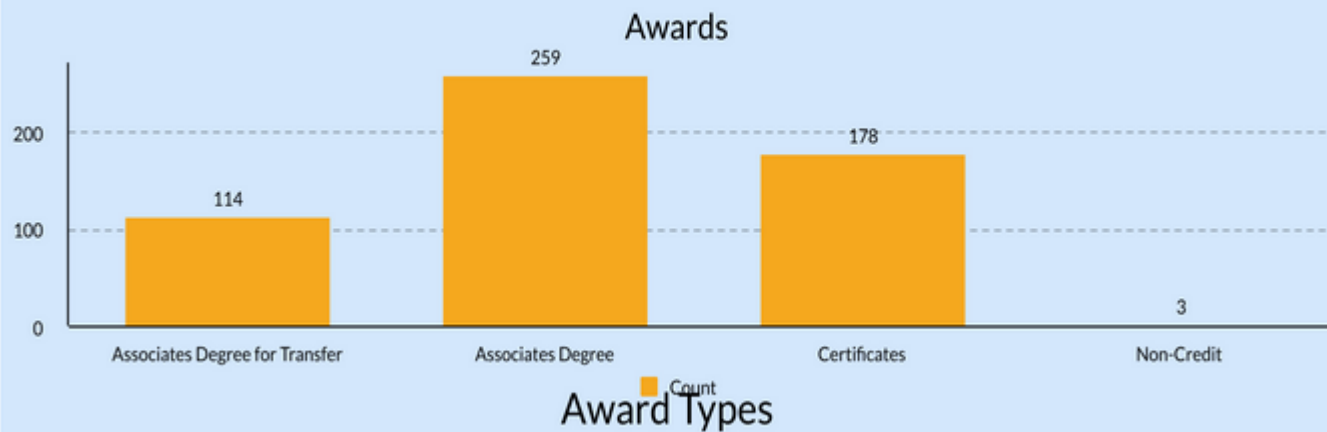

PROGRAM HIGHLIGHTS

STEM EDUCATION

For the Coast Center the strategic direction is to build STEM (Science, Technology, Engineering, Mathematics) focus.

- An example is our current campaign through the Mendocino College Foundation: Friends of the MC Coast Center to raise funds to establish a physiology lab. This is a gateway course to STEM and Allied Health pathways. These courses in combination with the on ground availability of human biology and chemistry, provide the opportunity for coastal students to obtain almost all of their nursing pre-requisites on the coast.
- Through quarterly meetings with principals and counselors, the three coastal HSs (FBHS, Mendocino HS and Point Arena HS) have been able to share ideas and resources. We are currently exploring ways to utilize our expertise with virtual education to offer a course on ground at one location while zooming to another site. Allowing us to offer courses, we would not otherwise have the faculty to instruct.

DUAL ENROLLMENT

Fort Bragg High School



Mendocino College VP Polak and FBUSD Superintendent Walker are pioneers of dual enrollment. We offer college and career success classes for every FBHS freshman. This ensures that every FBHS student is a Mendocino College student. We are currently developing four year dual enrollment schedules that, with Upward Bound summer courses and AP classes, will allow a FBHS student to obtain their AA while in HS. CTE certificate is also being developed.

Fine Woodworking

The Coast Center is proud to offer the Fine Woodworking Program, which leads to two possible certificates of achievement.

<https://thekrenovschool.org>





Questions



City of Fort Bragg

416 N Franklin Street
Fort Bragg, CA 95437
Phone: (707) 961-2823
Fax: (707) 961-2802

Text File

File Number: 21-209

Agenda Date: 5/10/2021

Version: 1

Status: Consent Agenda

In Control: City Council

File Type: Resolution

Agenda Number: 5A.

Amend City Council Resolution 4365-2021 Approving a Professional Services Agreement with Parker Lucas & Associates DBA Community Development Services for Community Development Block Grant (CDBG) Funded Business Loan Services and Authorizing City Manager to Execute Same (Amount Not to Exceed \$105,774; Account No. 331-5035-0630) The City Council adopted Resolution No. 4365-2021 on March 22, 2021 approving a contract with Community Development Services (CDS) for CDBG business loan services in the amount of \$102,013. In order to comply with Section 5.0(d) of the Professional Services Agreement, CDS must obtain professional errors and omissions (E&O) liability insurance with limits of One Million Dollars. The cost of the E&O insurance is \$3,761 which CDS has asked to be included in the amount of the contract. Approval of the amended resolution will increase the contract amount from \$102,013 to \$105,774.

**AMENDED
RESOLUTION NO. 4365-2021**

RESOLUTION OF THE FORT BRAGG CITY COUNCIL APPROVING A PROFESSIONAL SERVICES AGREEMENT WITH PARKER LUCAS & ASSOCIATES DBA COMMUNITY DEVELOPMENT SERVICES (CDS) FOR COMMUNITY DEVELOPMENT BLOCK GRANT (CDBG) BUSINESS LOAN SERVICES AND AUTHORIZES CITY MANAGER TO EXECUTE SAME (AMOUNT NOT TO EXCEED \$105,774; ACCOUNT NO. 331-5035-0630)

WHEREAS, the City of Fort Bragg wishes to be proactive in the creation of economic development opportunities for the community; and

WHEREAS, the City applied for and was awarded Community Development Block Grant (CDBG) funding to provide financial assistance to businesses; and

WHEREAS, the City of Fort Bragg will have three active CDBG awards to provide financial assistance to businesses; and

WHEREAS, a Request for Proposals (RFP) for consultant services to provide CDBG loan underwriting activities and other CDBG business assistance program activities was broadly released on October 21, 2020, and the only response was from Community Development Services (CDS); and

WHEREAS, CDS is a highly qualified CDBG economic development consulting firm that is one of the firms on the CDBG Business Assistance Underwriting Consultant List; and

WHEREAS, a City review team evaluated the proposals and determined that Community Development Services is specially trained, experienced, and competent to perform the special services required and recommended award of a contract to Community Development Services, and

WHEREAS, based on all the evidence presented, the City Council finds as follows:

1. Securing services from Community Development Services (CDS) will ensure that the City is prepared to engage in economic development opportunities funded through the CDBG program.
2. A City review team reviewed the CDS proposal and found CDS to be specially trained, experienced, and competent to perform the required tasks.
3. There is sufficient General Administration funding available from awarded and upcoming awards through CDBG grants to pay for business loan development and loan servicing activities.

NOW, THEREFORE, BE IT RESOLVED that the City Council of the City of Fort Bragg does hereby approve a Professional Services Agreement with Community Development Services for Community Development Block Grant Funded Business Loan Services and authorizes the City Manager to Execute Same (Amount Not to Exceed \$105,774; Account No. 331-5035-0630).

The above and foregoing Resolution was introduced by Councilmember _____, seconded by Councilmember _____, and passed and adopted at a regular

meeting of the City Council of the City of Fort Bragg held on the 10th day of May, 2021,
by the following vote:

AYES:
NOES:
ABSENT:
ABSTAIN:
RECUSED:

BERNIE NORVELL
Mayor

ATTEST:

June Lemos, CMC
City Clerk

RESOLUTION NO. 4365-2021

RESOLUTION OF THE FORT BRAGG CITY COUNCIL APPROVING A PROFESSIONAL SERVICES AGREEMENT WITH PARKER LUCAS & ASSOCIATES DBA COMMUNITY DEVELOPMENT SERVICES (CDS) FOR COMMUNITY DEVELOPMENT BLOCK GRANT (CDBG) BUSINESS LOAN SERVICES AND AUTHORIZES CITY MANAGER TO EXECUTE SAME (AMOUNT NOT TO EXCEED \$102,013; ACCOUNT NO. 331-5035-0630)

WHEREAS, the City of Fort Bragg wishes to be proactive in the creation of economic development opportunities for the community; and

WHEREAS, the City applied for and was awarded Community Development Block Grant (CDBG) funding to provide financial assistance to businesses; and

WHEREAS, the City of Fort Bragg will have three active CDBG awards to provide financial assistance to businesses; and

WHEREAS, a Request for Proposals (RFP) for consultant services to provide CDBG loan underwriting activities and other CDBG business assistance program activities was broadly released on October 21, 2020, and the only response was from Community Development Services (CDS); and

WHEREAS, CDS is a highly qualified CDBG economic development consulting firm that is one of the firms on the CDBG Business Assistance Underwriting Consultant List; and

WHEREAS, a City review team evaluated the proposals and determined that Community Development Services is specially trained, experienced, and competent to perform the special services required and recommended award of a contract to Community Development Services, and

WHEREAS, based on all the evidence presented, the City Council finds as follows:

1. Securing services from Community Development Services (CDS) will ensure that the City is prepared to engage in economic development opportunities funded through the CDBG program.
2. A City review team reviewed the CDS proposal and found CDS to be specially trained, experienced, and competent to perform the required tasks.
3. There is sufficient General Administration funding available from awarded and upcoming awards through CDBG grants to pay for business loan development and loan servicing activities.

NOW, THEREFORE, BE IT RESOLVED that the City Council of the City of Fort Bragg does hereby approve the a Professional Services Agreement with Community Development Services for Community Development Block Grant Funded Business Loan Services and authorizes the City Manager to Execute Same (Amount Not to Exceed \$103,013; Account No. 331-5035-0630).

The above and foregoing Resolution was introduced by Councilmember Peters, seconded by Councilmember Albin-Smith, and passed and adopted at a regular meeting

of the City Council of the City of Fort Bragg held on the 22nd day of March, 2021, by the following vote:

AYES: Councilmembers Albin-Smith, Morsell-Haye, Rafanan, Peters and Mayor Norvell.
NOES: None.
ABSENT: None.
ABSTAIN: None.
RECUSED: None.



BERNIE NORVELL
Mayor

ATTEST:



June Lemos, CMC
City Clerk

**CITY OF FORT BRAGG
PROFESSIONAL SERVICES AGREEMENT
WITH
COMMUNITY DEVELOPMENT SERVICES**

THIS AGREEMENT is made and entered into this ____ day of May, 2021 (“Effective Date”), by and between the CITY OF FORT BRAGG, a municipal corporation, 416 N. Franklin Street, Fort Bragg, California 95437 (“City”), and PARKER LUCAS & ASSOCIATES DBA COMMUNITY DEVELOPMENT SERVICES, a California corporation, 3895 Main Street, Kelseyville, California 95451 (“Consultant”).

WITNESSETH:

A. WHEREAS, City proposes to utilize the services of Consultant as an independent contractor to provide loan underwriting services for Community Development Block Grant activities as more fully described herein; and

B. WHEREAS, City and Consultant desire to contract for the specific services described in Exhibit “A” (the “Project”) and desire to set forth their rights, duties and liabilities in connection with the services to be performed; and

C. WHEREAS, no official or employee of City has a financial interest, within the provisions of Sections 1090-1092 of the California Government Code, in the subject matter of this Agreement.

D. WHEREAS, the legislative body of the City on May 10, 2021 by Resolution No. _____ authorized execution of this Agreement on behalf of the City in accordance with Chapter 3.20 of the City Municipal Code and/or other applicable law;

NOW, THEREFORE, for and in consideration of the mutual covenants and conditions contained herein, the parties hereby agree as follows:

1.0. SERVICES PROVIDED BY CONSULTANT

1.1. Scope of Work. Consultant shall provide the professional services described in the Consultant’s Proposal (“Proposal”), attached hereto as **Exhibit A** and incorporated herein by this reference.

1.2. Professional Practices. All professional services to be provided by Consultant pursuant to this Agreement shall be provided by personnel experienced in their respective fields and in a manner consistent with the standards of care, diligence and skill ordinarily exercised by professional consultants in similar fields and circumstances in accordance with sound professional practices. Consultant also warrants that it is familiar with all laws that may affect its performance of this Agreement and shall advise City of any changes in any laws that may affect Consultant’s performance of this Agreement. Consultant shall keep itself informed of State and Federal laws and regulations which in any manner affect those employed by it or in any way affect the performance of its service pursuant to this Agreement. The Consultant shall at all times observe and comply with all such laws and regulations. City officers and employees shall not be liable at law or in equity occasioned by failure of the Consultant to comply with this section.

1.3. Performance to Satisfaction of City. Consultant agrees to perform all the work to the complete satisfaction of the City as hereinafter specified. Evaluations of the work will be done by the City Manager or his or her designee. If the quality of work is not satisfactory, City in its

discretion has the right to:

- (a) Meet with Consultant to review the quality of the work and resolve the matters of concern;
- (b) Require Consultant to repeat the work at no additional fee until it is satisfactory; and/or
- (c) Terminate the Agreement as hereinafter set forth.

1.4. Warranty. Consultant warrants that it shall perform the services required by this Agreement in compliance with all applicable Federal and California employment laws, including, but not limited to, those laws related to minimum hours and wages; occupational health and safety; fair employment and employment practices; workers' compensation insurance and safety in employment; and all other Federal, State and local laws and ordinances applicable to the services required under this Agreement. Consultant shall indemnify and hold harmless City from and against all claims, demands, payments, suits, actions, proceedings, and judgments of every nature and description including attorneys' fees and costs, presented, brought, or recovered against City for or on account of any liability under any of the above-mentioned laws, which may be incurred by reason of Consultant's performance under this Agreement. To the extent that this Agreement may be funded by fiscal assistance from another governmental entity, Consultant and any subcontractors shall comply with all applicable rules and regulations to which City is bound by the terms of such fiscal assistance program.

1.5. Non-discrimination. In performing this Agreement, Consultant shall not engage in, nor permit its agents to engage in, discrimination in employment of persons because of their race, religion, color, national origin, ancestry, age, physical handicap, medical condition, marital status, sexual gender, sexual orientation, or disability except as permitted pursuant to Section 12940 of the Government Code. Such actions shall include, but not be limited to the following: employment, upgrading, demotion or transfer, recruitment or recruitment advertising, layoff or termination, rates of pay or other forms of compensation and selection for training, including apprenticeship. Consultant agrees to post in conspicuous places, available to employees and applicants for employment, a notice setting forth provisions of this non-discrimination clause.

Consultant shall, in all solicitations and advertisements for employees placed by, or on behalf of Consultant, state that all qualified applicants will receive consideration for employment without regard to race, religion, color, national origin, ancestry, age, physical handicap, medical condition, marital status, sexual gender, sexual orientation, or disability. Consultant shall cause the paragraphs contained in this Section to be inserted in all subcontracts for any work covered by the Agreement, provided that the foregoing provisions shall not apply to subcontracts for standard commercial supplies or raw materials.

1.6. Non-Exclusive Agreement. Consultant acknowledges that City may enter into agreements with other consultants for services similar to the services that are subject to this Agreement or may have its own employees perform services similar to those services contemplated by this Agreement.

1.7. Delegation and Assignment. This is a personal service contract, and the duties set forth herein shall not be delegated or assigned to any person or entity without the prior written consent of City. Consultant may engage a subcontractor(s) as permitted by law and may employ other personnel to perform services contemplated by this Agreement at Consultant's sole cost and expense. All insurance requirements contained in this Agreement are independently applicable to any and all subcontractors that Consultant may engage during the term of this Agreement.

1.8. Confidentiality. Employees of Consultant in the course of their duties may have access to financial, accounting, statistical, and personnel data of private individuals and employees of City. Consultant covenants that all data, documents, discussion, or other information developed or received by Consultant or provided for performance of this Agreement are deemed confidential and shall not be disclosed by Consultant without written authorization by City. City shall grant such authorization if disclosure is required by law. All City data shall be returned to City upon the termination of this Agreement. Consultant's covenant under this Section shall survive the termination of this Agreement.

2.0. COMPENSATION AND BILLING

2.1. Compensation. Consultant's total compensation shall not exceed **One Hundred Five Thousand Seven Hundred Seventy-four Dollars (\$105,774.00)**.

2.2. Additional Services. Consultant shall not receive compensation for any services provided outside the scope of work specified in the Consultant's Proposal or which is inconsistent with or in violation of the provisions of this Agreement unless the City or the Project Manager for this Project, prior to Consultant performing the additional services, approves such additional services in writing. It is specifically understood that oral requests and/or approvals of such additional services or additional compensation shall be barred and are unenforceable. Should the City request in writing additional services that increase the hereinabove described "Scope of Work," an additional fee based upon the Consultant's standard hourly rates shall be paid to the Consultant for such additional services. The City Manager may approve contract change orders not exceeding a total of 10% of the approved contract or up to the contingency amount whichever amount is less for any one project.

2.3. Method of Billing. Consultant may submit invoices to the City for approval on a progress basis, but not more often than monthly. Said invoice shall be based on the total of all Consultant's services which have been completed to City's sole satisfaction. City shall pay Consultant's invoice within forty-five (45) days from the date City receives said invoice. Each invoice shall describe in detail, the services performed, the date of performance, and the associated time for completion. Any additional services approved and performed pursuant to this Agreement shall be designated as "Additional Services" and shall identify the number of the authorized change order, where applicable, on all invoices.

2.4. Records and Audits. Records of Consultant's services relating to this Agreement shall be maintained in accordance with generally recognized accounting principles and shall be made available to City or its Project Manager for inspection and/or audit at mutually convenient times for a period of three (3) years from the date of final payment.

3.0. TIME OF PERFORMANCE

3.1. Commencement and Completion of Work. The professional services to be performed pursuant to this Agreement shall commence within five (5) days from the issuance of Notice to Proceed. Said services shall be performed in strict compliance with the schedule set forth in the Scope of Work attached hereto as **Exhibit A**. Consultant will complete the services in accordance with this Agreement by **March 31, 2026**. The Time of Completion may only be modified by a written amendment of the Agreement signed by both the City and the Consultant and in accordance with its terms.

3.2. Excusable Delays. Neither party shall be responsible for delays or lack of performance resulting from acts beyond the reasonable control of the party or parties. Such acts shall include, but not be limited to, acts of God, fire, strikes, material shortages, compliance with

laws or regulations, riots, acts of war, or any other conditions beyond the reasonable control of a party. If a delay beyond the control of the Consultant is encountered, a time extension may be mutually agreed upon in writing by the City and the Consultant. The Consultant shall present documentation satisfactory to the City to substantiate any request for a time extension.

4.0. TERM AND TERMINATION

4.1. Term. This Agreement shall commence on the Effective Date and expire on **June 30, 2026** unless previously terminated as provided herein or as otherwise agreed to in writing by the parties.

4.2. Notice of Termination. The City reserves and has the right and privilege of canceling, suspending or abandoning the execution of all or any part of the work contemplated by this Agreement, with or without cause, at any time, by providing at least ten (10) days prior written notice to Consultant. The termination of this Agreement shall be deemed effective upon receipt of the notice of termination. In the event of such termination, Consultant shall immediately stop rendering services under this Agreement unless directed otherwise by the City. If the City suspends, terminates or abandons a portion of this Agreement, such suspension, termination or abandonment shall not make void or invalidate the remainder of this Agreement.

If the Consultant defaults in the performance of any of the terms or conditions of this Agreement, it shall have ten (10) days after service upon it of written notice of such default in which to cure the default by rendering a satisfactory performance. In the event that the Consultant fails to cure its default within such period of time, the City shall have the right, notwithstanding any other provision of this Agreement, to terminate this Agreement without further notice and without prejudice to any other remedy to which it may be entitled at law, in equity or under this Agreement.

The City shall have the right, notwithstanding any other provisions of this Agreement, to terminate this Agreement, at its option and without prejudice to any other remedy to which it may be entitled at law, in equity or under this Agreement, immediately upon service of written notice of termination on the Consultant, if the latter should:

- a. Be adjudged a bankrupt;
- b. Become insolvent or have a receiver of its assets or property appointed because of insolvency;
- c. Make a general assignment for the benefit of creditors;
- d. Default in the performance of any obligation or payment of any indebtedness under this Agreement;
- e. Suffer any judgment against it to remain unsatisfied or unbonded of record for thirty (30) days or longer; or
- f. Institute or suffer to be instituted any procedures for reorganization or rearrangement of its affairs.

4.3. Compensation. In the event of termination, City shall pay Consultant for reasonable costs incurred and professional services satisfactorily performed up to and including the date of City's written notice of termination within thirty-five (35) days after service of the notice of termination. Compensation for work in progress shall be prorated based on the percentage of work completed as of the effective date of termination in accordance with the fees set forth herein.

In ascertaining the professional services actually rendered hereunder up to the effective date of termination of this Agreement, consideration shall be given to both completed work and work in progress, to complete and incomplete drawings, and to other documents pertaining to the services contemplated herein whether delivered to the City or in the possession of the Consultant. City shall not be liable for any claim of lost profits.

4.4. Documents. In the event of termination of this Agreement, all documents prepared by Consultant in its performance of this Agreement including, but not limited to, finished or unfinished design, development and construction documents, data studies, drawings, maps and reports, shall be delivered to the City within ten (10) days of delivery of termination notice to Consultant, at no cost to City. Any use of uncompleted documents without specific written authorization from Consultant shall be at City's sole risk and without liability or legal expense to Consultant.

5.0. INSURANCE

5.1. Minimum Scope and Limits of Insurance. Consultant shall obtain, maintain, and keep in full force and effect during the life of this Agreement all of the following minimum scope of insurance coverages with an insurance company admitted to do business in California, rated "A," Class X, or better in the most recent Best's Key Insurance Rating Guide, and approved by City:

- (a) Broad-form commercial general liability, in a form at least as broad as ISO form #CG 20 01 04 13, including premises-operations, products/ completed operations, broad form property damage, blanket contractual liability, independent contractors, personal injury or bodily injury with a policy limit of not less than One Million Dollars (\$1,000,000.00) per occurrence, Two Million Dollars (\$2,000,000.00) aggregate, combined single limits. If such insurance contains a general aggregate limit, it shall apply separately to this Agreement or shall be twice the required occurrence limit. If Consultant maintains higher limits than the specified minimum limits, City requires and shall be entitled to coverage for the high limits maintained by the Consultant.
- (b) Business automobile liability for owned vehicles, hired, and non-owned vehicles, with a policy limit of not less than One Million Dollars (\$1,000,000.00), combined single limits, each incident for bodily injury and property damage.
- (c) Workers' compensation insurance as required by the State of California and Employers Liability Insurance with a minimum limit of \$1,000,000 per accident for any employee or employees of Consultant. Consultant agrees to waive, and to obtain endorsements from its workers' compensation insurer waiving subrogation rights under its workers' compensation insurance policy against the City, its officials, officers, agents, employees, and volunteers for losses arising from work performed by Consultant for the City and to require each of its subcontractors, if any, to do likewise under their workers' compensation insurance policies.

Before execution of this Agreement by the City, the Consultant shall file with the City Clerk the following signed certification:

I am aware of, and will comply with, Section 3700 of the Labor Code, requiring every employer to be insured against liability of

Workers' Compensation or to undertake self-insurance before commencing any of the work.

The Consultant shall also comply with Section 3800 of the Labor Code by securing, paying for and maintaining in full force and effect for the duration of this Agreement, complete Workers' Compensation Insurance, and shall furnish a Certificate of Insurance to the City Clerk before execution of this Agreement by the City. The City, its officers and employees shall not be responsible for any claims in law or equity occasioned by failure of the consultant to comply with this section.

- (d) Professional errors and omissions ("E&O") liability insurance with policy limits of not less than One Million Dollars (\$1,000,000.00), combined single limits, per occurrence and aggregate. Architects' and engineers' coverage shall be endorsed to include contractual liability. If the policy is written as a "claims made" policy, the retro date shall be prior to the start of the contract work. Consultant shall obtain and maintain said E&O liability insurance during the life of this Agreement and for three years after completion of the work hereunder.

Neither the City nor any of its elected or appointed officials, officers, agents, employees, or volunteers makes any representation that the types of insurance and the limits specified to be carried by Consultant under this Agreement are adequate to protect Consultant. If Consultant believes that any such insurance coverage is insufficient, Consultant shall provide, at its own expense, such additional insurance as Consultant deems adequate.

5.2. Endorsements. The commercial general liability insurance policy and business automobile liability policy shall contain or be endorsed to contain the following provisions:

- (a) Additional insureds: "The City of Fort Bragg and its elected and appointed boards, officers, officials, agents, employees, and volunteers are additional insureds with respect to: liability arising out of activities performed by or on behalf of the Consultant pursuant to its contract with the City; products and completed operations of the Consultant; premises owned, occupied or used by the Consultant; automobiles owned, leased, hired, or borrowed by the Consultant."
- (b) Notice: "Consultant shall provide immediate written notice if (1) any of the required insurance policies is terminated; (2) the limits of any of the required policies are reduced; or (3) the deductible or self-insured retention is increased. In the event of any cancellation or reduction in coverage or limits of any insurance, Consultant shall forthwith obtain and submit proof of substitute insurance. Should Consultant fail to immediately procure other insurance, as specified, to substitute for any canceled policy, the City may procure such insurance at Consultant's sole cost and expense."
- (c) Other insurance: "The Consultant's insurance coverage shall be primary insurance as respects the City of Fort Bragg, its officers, officials, agents, employees, and volunteers. Any other insurance maintained by the City of Fort Bragg shall be excess and not contributing with the insurance provided by this policy."
- (d) Any failure to comply with the reporting provisions of the policies shall not affect coverage provided to the City of Fort Bragg, its officers, officials,

agents, employees, and volunteers.

- (e) The Consultant's insurance shall apply separately to each insured against whom claim is made or suit is brought, except with respect to the limits of the insurer's liability.

5.3. Deductible or Self-Insured Retention. If any of such policies provide for a deductible or self-insured retention to provide such coverage, the amount of such deductible or self-insured retention shall be approved in advance by City. No policy of insurance issued as to which the City is an additional insured shall contain a provision which requires that no insured except the named insured can satisfy any such deductible or self-insured retention.

5.4. Certificates of Insurance. Consultant shall provide to City certificates of insurance showing the insurance coverages and required endorsements described above, in a form and content approved by City, prior to performing any services under this Agreement. The certificates of insurance and endorsements shall be attached hereto as **Exhibit B** and incorporated herein by this reference.

5.5. Non-limiting. Nothing in this Section shall be construed as limiting in any way, the indemnification provision contained in this Agreement, or the extent to which Consultant may be held responsible for payments of damages to persons or property.

6.0 OTHER GOVERNMENTAL REGULATIONS

6.1 Compliance. To the extent that this Agreement may be funded by fiscal assistance from another governmental entity, Consultant and any subcontractors shall comply with all applicable rules and regulations to which City is bound by the terms of such fiscal assistance program.

6.2 CDBG Requirements. Required contract provisions for Community Development Block Grant (CDBG)-Aided Consultant Contracts are attached as **Exhibit C**, and said provisions are incorporated into this Agreement by reference. All forms provided in **Exhibit C** are to be completed and attached to this Agreement.

7.0. GENERAL PROVISIONS

7.1. Entire Agreement. This Agreement constitutes the entire agreement between the parties with respect to any matter referenced herein and supersedes any and all other prior writings and oral negotiations. This Agreement may be modified only in writing, and signed by the parties in interest at the time of such modification. The terms of this Agreement shall prevail over any inconsistent provision in any other contract document appurtenant hereto, including exhibits to this Agreement.

7.2. Representatives. The City Manager or his or her designee shall be the representative of City for purposes of this Agreement and may issue all consents, approvals, directives and agreements on behalf of the City, called for by this Agreement, except as otherwise expressly provided in this Agreement.

Consultant shall designate a representative for purposes of this Agreement who shall be authorized to issue all consents, approvals, directives and agreements on behalf of Consultant called for by this Agreement, except as otherwise expressly provided in this Agreement.

7.3. Project Managers. The Project Manager designated to work directly with

Consultant in the performance of this Agreement will be **Natalie McLaughli**. It shall be the Consultant's responsibility to assure that the Project Manager is kept informed of the progress of the performance of the services and the Consultant shall refer any decision, which must be made by City, to the Project Manager. Unless otherwise specified herein, any approval of City required hereunder shall mean the approval of the Project Manager.

Consultant designates **Jeff Lucas** as its Project Manager, who shall represent it and be its agent in all consultations with City during the term of this Agreement and who shall not be changed by Consultant without the express written approval by the City. Consultant or its Project Manager shall attend and assist in all coordination meetings called by City.

7.4. Notices. Any notices, documents, correspondence or other communications concerning this Agreement or the work hereunder may be provided by personal delivery, facsimile or if mailed, shall be addressed as set forth below and placed in a sealed envelope, postage prepaid, and deposited in the United States Postal Service. Such communication shall be deemed served or delivered: a) at the time of delivery if such communication is sent by personal delivery; b) at the time of transmission if such communication is sent by facsimile; and c) 72 hours after deposit in the U.S. Mail as reflected by the official U.S. postmark if such communication is sent through regular United States mail.

IF TO CONSULTANT:

Jeff Lucas
Community Development Services
3895 Main Street
Kelseyville, CA 95451
Tel: 707-279-1540

IF TO CITY:

City Clerk
City of Fort Bragg
416 N. Franklin St.
Fort Bragg, CA 95437
Tel: 707-961-2823
Fax: 707-961-2802

7.5. Attorneys' Fees. In the event that litigation is brought by any party in connection with this Agreement, the prevailing party shall be entitled to recover from the opposing party all costs and expenses, including reasonable attorneys' fees, incurred by the prevailing party in the exercise of any of its rights or remedies hereunder or the enforcement of any of the terms, conditions, or provisions hereof.

7.6. Governing Law. This Agreement shall be governed by and construed under the laws of the State of California without giving effect to that body of laws pertaining to conflict of laws. In the event of any legal action to enforce or interpret this Agreement, the parties hereto agree that the sole and exclusive venue shall be a court of competent jurisdiction located in Mendocino County, California. Consultant agrees to submit to the personal jurisdiction of such court in the event of such action.

7.7. Assignment. Consultant shall not voluntarily or by operation of law assign, transfer, sublet or encumber all or any part of Consultant's interest in this Agreement without City's prior written consent. Any attempted assignment, transfer, subletting or encumbrance shall be void and shall constitute a breach of this Agreement and cause for termination of this Agreement. Regardless of City's consent, no subletting or assignment shall release Consultant of Consultant's obligation to perform all other obligations to be performed by Consultant hereunder for the term of this Agreement.

7.8. Indemnification and Hold Harmless. If Consultant is not a design professional performing "design professional" services under this Agreement, as that term is defined in Civil Code Section 2782.8, Consultant agrees to defend, indemnify, hold free and harmless the City, its elected and appointed officials, officers, agents and employees, at Consultant's sole expense,

from and against any and all claims, demands, actions, suits or other legal proceedings brought against the City, its elected and appointed officials, officers, agents and employees arising out of the performance of the Consultant, its employees, and/or authorized subcontractors, of the work undertaken pursuant to this Agreement. The defense obligation provided for hereunder shall apply whenever any claim, action, complaint or suit asserts liability against the City, its elected and appointed officials, officers, agents and employees based upon the work performed by the Consultant, its employees, and/or authorized subcontractors under this Agreement, whether or not the Consultant, its employees, and/or authorized subcontractors are specifically named or otherwise asserted to be liable. Notwithstanding the foregoing, the Consultant shall not be liable for the defense or indemnification of the City for claims, actions, complaints or suits arising out of the sole active negligence or willful misconduct of the City. This provision shall supersede and replace all other indemnity provisions contained either in the City's specifications or Consultant's Proposal, which shall be of no force and effect.

If Consultant is a design professional performing "design professional" services under this Agreement, as that term is defined in Civil Code Section 2782.8, Consultant agrees to defend, indemnify, hold free and harmless the City, its elected and appointed officials, officers, agents and employees, at Consultant's sole expense, from and against any and all claims, demands, actions, suits or other legal proceedings arising out of, pertaining to, or relating to the negligence, recklessness, or willful misconduct of Consultant brought against the City, its elected and appointed officials, officers, agents and employees arising out of the performance of the Consultant, its employees, and/or authorized subcontractors, of the work undertaken pursuant to this Agreement. The defense obligation provided for hereunder shall apply whenever any claim, action, complaint or suit asserts liability against the City, its elected and appointed officials, officers, agents and employees based upon the negligence, recklessness, or willful misconduct of the Consultant, its employees, and/or authorized subcontractors under this Agreement, whether or not the Consultant, its employees, and/or authorized subcontractors are specifically named or otherwise asserted to be liable. Notwithstanding the foregoing, the Consultant shall not be liable for the defense or indemnification of the City for claims, actions, complaints or suits arising out of the sole active negligence or willful misconduct of the City. This provision shall supersede and replace all other indemnity provisions contained either in the City's specifications or Consultant's Proposal, which shall be of no force and effect.

7.9. Independent Contractor. Consultant is and shall be acting at all times as an independent contractor and not as an employee of City. Consultant shall have no power to incur any debt, obligation, or liability on behalf of City or otherwise act on behalf of City as an agent. Neither City nor any of its agents shall have control over the conduct of Consultant or any of Consultant's employees, except as set forth in this Agreement. Consultant shall not, at any time, or in any manner, represent that it or any of its or employees are in any manner agents or employees of City. Consultant shall secure, at its sole expense, and be responsible for any and all payment of Income Tax, Social Security, State Disability Insurance Compensation, Unemployment Compensation, and other payroll deductions for Consultant and its officers, agents, and employees, and all business licenses, if any are required, in connection with the services to be performed hereunder. Consultant shall indemnify and hold City harmless from any and all taxes, assessments, penalties, and interest asserted against City by reason of the independent contractor relationship created by this Agreement. Consultant further agrees to indemnify and hold City harmless from any failure of Consultant to comply with the applicable worker's compensation laws. City shall have the right to offset against the amount of any fees due to Consultant under this Agreement any amount due to City from Consultant as a result of Consultant's failure to promptly pay to City any reimbursement or indemnification arising under this paragraph.

7.10. PERS Eligibility Indemnification. In the event that Consultant or any employee, agent, or subcontractor of Consultant providing services under this Agreement claims or is

determined by a court of competent jurisdiction or the California Public Employees Retirement System (PERS) to be eligible for enrollment in PERS as an employee of the City, Consultant shall indemnify, defend, and hold harmless City for the payment of any employee and/or employer contributions for PERS benefits on behalf of Consultant or its employees, agents, or subcontractors, as well as for the payment of any penalties and interest on such contributions, which would otherwise be the responsibility of City.

Notwithstanding any other agency, state or federal policy, rule, regulation, law or ordinance to the contrary, Consultant and any of its employees, agents, and subcontractors providing service under this Agreement shall not qualify for or become entitled to, and hereby agree to waive any claims to, any compensation, benefit, or any incident of employment by City, including but not limited to eligibility to enroll in PERS as an employee of City and entitlement to any contribution to be paid by City for employer contribution and/or employee contributions for PERS benefits.

7.11. Cooperation. In the event any claim or action is brought against City relating to Consultant's performance or services rendered under this Agreement, Consultant shall render any reasonable assistance and cooperation which City might require.

7.12. Ownership of Documents. All findings, reports, documents, information and data including, but not limited to, computer tapes or discs, preliminary notes, working documents, files and tapes furnished or prepared by Consultant or any of its subcontractors in the course of performance of this Agreement, shall be and remain the sole property of City. Consultant agrees that any such documents or information shall not be made available to any individual or organization without the prior consent of City, but shall be made available to the City within ten (10) days of request or within ten (10) days of termination. Any use of such documents for other projects not contemplated by this Agreement, and any use of incomplete documents, shall be at the sole risk of City and without liability or legal exposure to Consultant. City shall indemnify and hold harmless Consultant from all claims, damages, losses, and expenses, including attorneys' fees, arising out of or resulting from City's use of such documents for other projects not contemplated by this Agreement or use of incomplete documents furnished by Consultant. Consultant shall deliver to City any findings, reports, documents, information, data, preliminary notes and working documents, in any form, including but not limited to, computer tapes, discs, files audio tapes or any other Project related items as requested by City or its authorized representative, at no additional cost to the City. Consultant or Consultant's agents shall execute such documents as may be necessary from time to time to confirm City's ownership of the copyright in such documents.

7.13. Public Records Act Disclosure. Consultant has been advised and is aware that this Agreement and all reports, documents, information and data, including, but not limited to, computer tapes, discs or files furnished or prepared by Consultant, or any of its subcontractors, pursuant to this Agreement and provided to City may be subject to public disclosure as required by the California Public Records Act (California Government Code Section 6250 *et seq.*). Exceptions to public disclosure may be those documents or information that qualify as trade secrets, as that term is defined in the California Government Code Section 6254.7, and of which Consultant informs City of such trade secret. The City will endeavor to maintain as confidential all information obtained by it that is designated as a trade secret. The City shall not, in any way, be liable or responsible for the disclosure of any trade secret including, without limitation, those records so marked if disclosure is deemed to be required by law or by order of the Court.

7.14. Conflict of Interest. Consultant and its officers, employees, associates and subconsultants, if any, will comply with all conflict of interest statutes of the State of California applicable to Consultant's services under this agreement, including, but not limited to, the Political Reform Act (Government Code Sections 81000, *et seq.*) and Government Code Section 1090.

During the term of this Agreement, Consultant and its officers, employees, associates and subconsultants shall not, without the prior written approval of the City Representative, perform work for another person or entity for whom Consultant is not currently performing work that would require Consultant or one of its officers, employees, associates or subconsultants to abstain from a decision under this Agreement pursuant to a conflict of interest statute.

7.15. Responsibility for Errors. Consultant shall be responsible for its work and results under this Agreement. Consultant, when requested, shall furnish clarification and/or explanation as may be required by the City's representative, regarding any services rendered under this Agreement at no additional cost to City. In the event that an error or omission attributable to Consultant occurs, then Consultant shall, at no cost to City, provide all necessary design drawings, estimates and other Consultant professional services necessary to rectify and correct the matter to the sole satisfaction of City and to participate in any meeting required with regard to the correction.

7.16. Prohibited Employment. Consultant will not employ any regular employee of City while this Agreement is in effect.

7.17. Order of Precedence. In the event of an inconsistency in this Agreement and any of the attached Exhibits, the terms set forth in this Agreement shall prevail. If, and to the extent this Agreement incorporates by reference any provision of any document, such provision shall be deemed a part of this Agreement. Nevertheless, if there is any conflict among the terms and conditions of this Agreement and those of any such provision or provisions so incorporated by reference, the conflict shall be resolved by giving precedence in the following order, if applicable: This Agreement, the City's Request for Proposals, the Consultant's Proposal.

7.18. Costs. Each party shall bear its own costs and fees incurred in the preparation and negotiation of this Agreement and in the performance of its obligations hereunder except as expressly provided herein.

7.19. No Third Party Beneficiary Rights. This Agreement is entered into for the sole benefit of City and Consultant and no other parties are intended to be direct or incidental beneficiaries of this Agreement and no third party shall have any right in, under or to this Agreement.

7.20. Headings. Paragraph and subparagraph headings contained in this Agreement are included solely for convenience and are not intended to modify, explain or to be a full or accurate description of the content thereof and shall not in any way affect the meaning or interpretation of this Agreement.

7.21. Construction. The parties have participated jointly in the negotiation and drafting of this Agreement. In the event an ambiguity or question of intent or interpretation arises with respect to this Agreement, this Agreement shall be construed as if drafted jointly by the parties and in accordance with its fair meaning. There shall be no presumption or burden of proof favoring or disfavoring any party by virtue of the authorship of any of the provisions of this Agreement.

7.22. Amendments. Only a writing executed by the parties hereto or their respective successors and assigns may amend this Agreement.

7.23. Waiver. The delay or failure of either party at any time to require performance or compliance by the other of any of its obligations or agreements shall in no way be deemed a waiver of those rights to require such performance or compliance. No waiver of any provision of this Agreement shall be effective unless in writing and signed by a duly authorized representative of the party against whom enforcement of a waiver is sought. The waiver of any right or remedy

in respect to any occurrence or event shall not be deemed a waiver of any right or remedy in respect to any other occurrence or event, nor shall any waiver constitute a continuing waiver.

7.24. Severability. If any provision of this Agreement is determined by a court of competent jurisdiction to be unenforceable in any circumstance, such determination shall not affect the validity or enforceability of the remaining terms and provisions hereof or of the offending provision in any other circumstance. Notwithstanding the foregoing, if the value of this Agreement, based upon the substantial benefit of the bargain for any party, is materially impaired, which determination made by the presiding court or arbitrator of competent jurisdiction shall be binding, then both parties agree to substitute such provision(s) through good faith negotiations.

7.25. Counterparts. This Agreement may be executed in one or more counterparts, each of which shall be deemed an original. All counterparts shall be construed together and shall constitute one agreement.

7.26. Corporate Authority. The persons executing this Agreement on behalf of the parties hereto warrant that they are duly authorized to execute this Agreement on behalf of said parties and that by doing so the parties hereto are formally bound to the provisions of this Agreement.

IN WITNESS WHEREOF, the parties hereto have caused this Agreement to be executed by and through their respective authorized officers, as of the date first above written.

CITY

CONSULTANT

By: _____
Tabatha Miller
Its: City Manager

By: _____
Jeff Lucas
Its: Principal

ATTEST:

By: _____
June Lemos, CMC
City Clerk

APPROVED AS TO FORM:

By: _____
Keith F. Collins
City Attorney

EXHIBIT A

Scope of Work

1. Business Financial Assistance Program Start Up

- a. CDS will review the City's CDBG Business Assistance Program narrative in cooperation with the City and State Housing and Community Development staff to develop procedures and the timeline for program implementation.
- b. CDS will prepare and utilize, subject to City approval, CDBG-compliant program application forms, loan closing documents, agreements, and any other documents as may be necessary to implement the Program. CDS has developed a standard loan application form packet which has been reviewed and approved periodically by HCD staff. We will provide these documents as well as the laser pro loan closing documents we use to City staff for review and approval. We will also review the document organization system we have developed with City staff and improve upon the system based on City staff input.
- c. CDS will assist City staff with HCD required administrative report forms for monthly grant drawdown's, bi annual & annual reporting, and grant closing activities as needed by City staff. We are very familiar with the reporting requirements and timelines associated with the CDBG ED program. These reporting functions, and the corresponding documentation, will be completed in cooperation with, and on approval of, City staff on an as needed basis. CDS will also prepare, at the City's request, any additional reporting documentation for use at the local level.
- d. In addition to the tasks described above, CDS will work with City staff to expand CDBG knowledge and capacity with regard to utilization of CDBG funds in accordance with City program goals and objectives. CDS will update staff on a regular basis regarding the ongoing implementation of CDBG ED programs.

2. Business Loan Program Project Application Outreach

a. CDS routinely works with both the private and public sectors in order to facilitate and implement cost effective services on behalf of local small businesses and prospective borrowers. CDS works with City staff, local banks, especially SBMC, the Chamber of Commerce and the EDFC to find and work up potential loans.

The most efficient marketing program is based on networking and word of mouth with loan application and program reference material being available at the local level through websites and at convenient locations. CDS will provide information for the City, Chamber, and local banks regarding the program and how to contact us. Referrals will be made from these sources and local businesses.

b. CDS will prepare information sheets regarding the program for reference by our referral network and for the general public.

c. CDS will cultivate the program network as described in section 2.a. in order to market the program throughout the city. CDS will meet regularly with local bank staff to market the loan program and search out referrals and companion loans. The face-to-face meetings, when appropriate, will be followed up with telephone contacts to bank commercial loan department contacts. CDS staff will participate in providing loan program webinars. CDS will also work closely with staff to advise potential borrowers of the availability of business loan funds, provide information as needed, and pursue potential deals as appropriate.

d. CDS will review and assist applicants with the loan application process and, as early on in the process as practicable, advise the applicant of the credit worthiness of the application and the potential fit with the CDBG business loan program. If the loan makes sense, we will package the deal and carry it forward.

e. Whenever possible CDS will refer applicants to local appropriate service providers when more work is necessary to prepare the applicant for future consideration. This is an important element of what we do.

f. The very best way to market this program is to successfully complete loans that work for the City and the business. It is the business community and the banks that will market the program for us if we do our jobs properly.

3. Business Loan Processing

a. CDS has two offices. The Colusa County office is located at 100 Sunrise Blvd. Suite A, in the Colusa County Industrial Park. The other CDS office is located at 3895 Main Street, Kelseyville CA 95451. Most of our loan processing work will be done in the Kelseyville office. On site meetings will occur in Fort Bragg at the business location. CDS will not package a loan without first meeting the business owner at their place of business.

- a. CDS will work with State CDBG staff to confirm CDBG eligibility based on job creation/retention potential and other criteria, maintain documentation, and perform tracking of job creation and public benefit. CDS has processed over 750 CDBG business loans over the past 30 years which have required ongoing communication and problem solving with bank and CDBG program staff.
- b. CDS analyzes every loan application utilizing the fundamental five Cs of credit analysis to determine creditworthiness and the CDBG Six Underwriting Criteria. The criteria are addressed in each loan proposal we prepare. This assessment includes running a credit check on each applicant with over 20% ownership of the business. Also, HCD now uses an employment forecast spreadsheet developed by CDS as part of the project review process. We will continue to use this spreadsheet as part of our loan proposals.
- c. CDS will use standard underwriting criteria in conjunction with CDBG ED overlay requirements during the underwriting process to mitigate lending risk as much as possible.
- d. CDS interviews the applicant, visits the business site, gathers the necessary documentation, analyzes the information, prepares the loan proposal, presents the loan proposal, documents the loan decision, prepares the additional necessary supporting documentation, prepares the loan check sheet and signature documents.
- e. CDS then prepares loan closing documents, prepares escrow instructions, and will work with City staff to properly disburse the loan funds.
- f. CDS will work with staff to arrange the loan committee meetings, present the proposal to the committee, and if approved, complete the approval process, prepare the loan closing documents and title instructions, work with staff on the drawdown of funds, assist, and report on job creation/retention fulfillment, low/mod income placements.

4. Loan Closing & Documentation

- a. CDS uses LaserPro® loan closing documentation software, the commercial loan industry standard. All loan conditions are reviewed by the loan committee and HCD staff for appropriateness. Hard copy originals of all loan closing documents will be provided for review by City staff.
- b. CDS follows appropriate program underwriting criteria and analysis for each loan using the appropriate CDBG Economic Development Business Loan Review Checklist to ensure compliance with CDBG Federal overlay requirements, National Objectives, Public Benefit and underwriting requirements. CDS participates in the development CDBG underwriting criteria and utilizes the HCD CDBG ED loan checklist on a routine basis.

- c. CDS will utilize LaserPro® documents and CDBG public benefit documentation in accordance with the loan conditions of each approved loan. These include promissory note, business loan agreement, deed of trust, UCC filings and other loan and loan closing documents required, utilizing industry standard documents that are CDBG-compliant.
- d. CDS will provide specific escrow instructions based on the conditions set by the loan committee and HCD staff after the preliminary title search is completed and the loan has been approved.
- e. CDS will communicate with the title company throughout the process. We often utilize Fidelity Title Company as they are experienced with CDBG lending practices.
- f. When we are able to arrange a companion loan, we will coordinate the issues of security, disbursement, and use of funds with the participating lender. CDS is an experienced lender, we prefer companion loans with local banks because we can share risk and spread our resources further.

5. Monitor Loan Performance

- a. If needed, CDS will assist the City with loan modifications as needed and present the modifications to the CDBG Loan Committee for review and approval. If approved, the modification is then memorialized and the loan documents revised to reflect the modification.
- b. If requested to do so, CDS will routinely perform required post loan closing tasks including monitoring the on-going viability of the borrowers, including recommendations for action if necessary; monitoring and documentation of job creation/retention as required; and periodic site visits to verify availability and condition of collateral, examine business records and procedures, and offer assistance, obtain annual business financials, tax returns, and make sure all insurance coverage documentation is in place.

6. General Administration Activities

- a. CDS will update loan related documents as needed in accordance with HCD CDBG ED program guidelines and requirements. Mr. Lucas talks with CDBG management staff on a weekly basis, and is up to date on CDBG program requirements.
- b. CDS will provide, in cooperation with the staff, ongoing liaison and advocacy on the City's behalf with the CDBG ED program field representatives and the program manager regarding all CDBG issues. CDS will perform this function at the direction of City staff. We will also act as an interpreter and advocate on behalf of the loan applicants and recipients.
- c. CDS will assist the City with implementing the program by providing routine updates on program changes and interpretations, as well as by being responsive to specific questions posed by staff by email or telephone. We acknowledge that the CDBG ED program is often changing;

therefore, we make a practice of regular communication with HCD staff. Whenever we are unclear, we contact staff for discussion and determination. On another level, as business lenders, we have a good deal of experience with assisting small and medium sized businesses. We often provide technical assistance to prospective borrowers, thus improving their debt service capacity.

d. CDS prepares all loan files in accordance with established business loan practices and in compliance with HCD CDBG program requirements. We will prepare all the necessary loan and CDBG compliance documentation, keeping copies of the files for day to day reference and reporting. The original loan agreements and all support documentation will be kept in a fire proof safe with the City for reference and legal purposes.

e. After termination of the contract, CDS will provide to the City all documents we have prepared on behalf of the program in an orderly fashion to ensure the proper transition of files, including status of follow-up items, grant close out, and other related documentation.

f. CDS has experienced many grant monitoring site visits and grant close outs. We will work with staff to make the necessary preparations and assist City staff to insure the close out occurs properly. CDS will prepare in advance of the actual monitoring by providing accurate and complete documentation in accordance with HCD standards. We will identify and correct any gaps and assist in scheduling the monitoring. CDS staff will be present during the monitoring. CDS will draft any follow up or response information needed as a result of the monitoring.

7. CDBG OTC On Call Duties

CDS will perform such other on-call duties, as may be necessary, but which cannot be specified in advanced so as to reasonably assure the successful implementation of the program and compliance with applicable regulations and policies promulgated by the State Department of Housing and Community Development. These activities may include writing and/or processing Over-the-Counter grant applications approved by HCD for economic development projects, attending HCD program workshops to ensure knowledge of the most current guidelines, research, report writing, grant application writing, market surveys and other duties as requested.

If the City determines that a business is appropriate for CDBG OTC financing, CDS will conduct the underwriting process in much the same way as presented in section 3 above. However, the interaction with HCD staff and the business applicant is much more detailed and time consuming when preparing an OTC. Historically, OTC projects require a grant application process separate from any existing open grants held by the jurisdiction. Therefore, the OTC application process can take up to nine months to complete. The cost for preparing an OTC can be as much as \$35,000, (280 hrs. x \$125/hr.) dependent on the complexity of the deal and the readiness and capacity of the business to provide us with the documentation we need. Because

of this, CDS would perform a preliminary determination of eligibility and appropriateness for consideration by the city and HCD before pursuing an OTC application.

Budget and Schedule of Charges

Our proposal is based on the assumption that HCD will approve the City CDBG funding application in the amount of \$500,000 of which 7.5% (\$37,500) is administration and 10% (\$50,000) is Activity Delivery. We are proposing our standard hourly rate for services to be provided at \$125 an hour. This rate includes all reproduction, supplies, and related costs. We do not bill for travel time. Our cost for services is \$7,500 for administrative work and \$50,000 for activity delivery.

Work Schedule

CDS is prepared to begin program implementation upon the approval to proceed from the City of Fort Bragg. We anticipate disbursing the available loan funds within twelve months of the beginning of program implementation.

Insurance

CDS will provide documentation of the required insurances if the City selects CDS to perform the services described above.

Consultant Agreement

CDS will agree to the contract provided with the RFP.

Community Development Services
Budget - Draft
CDBG 19-20 BA & ME
CV2&3

Grant Total \$ 500,000.00 \$ 117,000.00 \$ 237,611.00

	19-20 BA	19-20 FA	CV2&3*
General Admin	\$ 7,500.00	\$ 1,000.00	\$ 4,752.00
Activity Delivery	\$ 50,000.00	\$ 15,000.00	\$ 23,761.00
Activity Total	\$ 57,500.00	\$ 16,000.00	\$ 28,513.00
Total Contract	\$ 102,013.00		



EXHIBIT B

CERTIFICATE OF LIABILITY INSURANCE

DATE (MM/DD/YYYY)

3/25/2021

THIS CERTIFICATE IS ISSUED AS A MATTER OF INFORMATION ONLY AND CONFERS NO RIGHTS UPON THE CERTIFICATE HOLDER. THIS CERTIFICATE DOES NOT AFFIRMATIVELY OR NEGATIVELY AMEND, EXTEND OR ALTER THE COVERAGE AFFORDED BY THE POLICIES BELOW. THIS CERTIFICATE OF INSURANCE DOES NOT CONSTITUTE A CONTRACT BETWEEN THE ISSUING INSURER(S), AUTHORIZED REPRESENTATIVE OR PRODUCER, AND THE CERTIFICATE HOLDER.

IMPORTANT: If the certificate holder is an ADDITIONAL INSURED, the policy(ies) must be endorsed. If SUBROGATION IS WAIVED, subject to the terms and conditions of the policy, certain policies may require an endorsement. A statement on this certificate does not confer rights to the certificate holder in lieu of such endorsement(s).

PRODUCER Lincoln-Leavitt 650 N Main St CA Lic. #0C73811 Lakeport CA 95453	CONTACT NAME: Aida Cruz PHONE (A/C No. Ext): (707) 263-7162 E-MAIL ADDRESS: aida-cruz@leavitt.com	FAX (A/C No): (707) 263-5018
	INSURER(S) AFFORDING COVERAGE	
INSURED Community Development Services, Inc 3895 Main St Kelseyville CA 95451	INSURER A: Sentinel Insurance Company	
	INSURER B:	
	INSURER C:	
	INSURER D:	
	INSURER E:	
	INSURER F:	

COVERAGES

CERTIFICATE NUMBER: CL2132503363

REVISION NUMBER:

THIS IS TO CERTIFY THAT THE POLICIES OF INSURANCE LISTED BELOW HAVE BEEN ISSUED TO THE INSURED NAMED ABOVE FOR THE POLICY PERIOD INDICATED. NOTWITHSTANDING ANY REQUIREMENT, TERM OR CONDITION OF ANY CONTRACT OR OTHER DOCUMENT WITH RESPECT TO WHICH THIS CERTIFICATE MAY BE ISSUED OR MAY PERTAIN, THE INSURANCE AFFORDED BY THE POLICIES DESCRIBED HEREIN IS SUBJECT TO ALL THE TERMS, EXCLUSIONS AND CONDITIONS OF SUCH POLICIES. LIMITS SHOWN MAY HAVE BEEN REDUCED BY PAID CLAIMS.

INSR LTR	TYPE OF INSURANCE	ADDL INSD	SUBR WVD	POLICY NUMBER	POLICY EFF (MM/DD/YYYY)	POLICY EXP (MM/DD/YYYY)	LIMITS	
A	<input checked="" type="checkbox"/> COMMERCIAL GENERAL LIABILITY <input type="checkbox"/> CLAIMS-MADE <input checked="" type="checkbox"/> OCCUR GEN'L AGGREGATE LIMIT APPLIES PER: <input checked="" type="checkbox"/> POLICY <input type="checkbox"/> PRO-JECT <input type="checkbox"/> LOC OTHER:	X		57SBAAX4777	4/18/2021	4/18/2022	EACH OCCURRENCE	\$ 1,000,000
							DAMAGE TO RENTED PREMISES (Ea occurrence)	\$ 1,000,000
							MED EXP (Any one person)	\$ 10,000
							PERSONAL & ADV INJURY	\$ 1,000,000
							GENERAL AGGREGATE	\$ 2,000,000
							PRODUCTS - COMP/OP AGG	\$ 2,000,000
							XCYBR	\$
A	AUTOMOBILE LIABILITY <input type="checkbox"/> ANY AUTO <input type="checkbox"/> ALL OWNED AUTOS <input checked="" type="checkbox"/> HIRED AUTOS <input type="checkbox"/> SCHEDULED AUTOS <input checked="" type="checkbox"/> NON-OWNED AUTOS			57SBAAX4777	4/18/2021	4/18/2022	COMBINED SINGLE LIMIT (Ea accident)	\$ 1,000,000
							BODILY INJURY (Per person)	\$
							BODILY INJURY (Per accident)	\$
							PROPERTY DAMAGE (Per accident)	\$
								\$
	UMBRELLA LIAB <input type="checkbox"/> EXCESS LIAB <input type="checkbox"/> OCCUR <input type="checkbox"/> CLAIMS-MADE <input type="checkbox"/> DED <input type="checkbox"/> RETENTION \$						EACH OCCURRENCE	\$
							AGGREGATE	\$
								\$
	WORKERS COMPENSATION AND EMPLOYERS' LIABILITY ANY PROPRIETOR/PARTNER/EXECUTIVE OFFICER/MEMBER EXCLUDED? (Mandatory in NH) If yes, describe under DESCRIPTION OF OPERATIONS below	Y/N	N/A				PER STATUTE	OTH-ER
							E.L. EACH ACCIDENT	\$
							E.L. DISEASE - EA EMPLOYEE	\$
							E.L. DISEASE - POLICY LIMIT	\$

DESCRIPTION OF OPERATIONS / LOCATIONS / VEHICLES (ACORD 101, Additional Remarks Schedule, may be attached if more space is required)

Certificate holder is included as an Additional Insured as respects the General Liability coverage per attached Form No. SS 12 11 04 05 T. Subject to all policy terms, conditions, limitations and exclusions.

CERTIFICATE HOLDER**CANCELLATION**

City of Fort Bragg, Including Its Officers, Officials, Employees and Volunteers 416 North Franklin Street Fort Bragg, CA 95437	SHOULD ANY OF THE ABOVE DESCRIBED POLICIES BE CANCELLED BEFORE THE EXPIRATION DATE THEREOF, NOTICE WILL BE DELIVERED IN ACCORDANCE WITH THE POLICY PROVISIONS. AUTHORIZED REPRESENTATIVE Aida Cruz Aida Cruz/AICRUZ
--	--

© 1988-2014 ACORD CORPORATION. All rights reserved.



THIS ENDORSEMENT CHANGES THE POLICY. PLEASE READ IT CAREFULLY.

ADDITIONAL INSURED - OWNERS, LESSEES OR CONTRACTORS - SCHEDULED PERSON OR ORGANIZATION

This endorsement modifies insurance provided under the following:

BUSINESS LIABILITY COVERAGE FORM

SCHEDULE

Name Of Additional Insured Person(s) Or Organization(s):

CITY OF FORT BRAGG

Location(s) Of Covered Operations:

416 N FRANKLIN ST., FORT BRAGG, CA 95437

Information required to complete this Schedule, if not shown above, will be shown in the Declarations.

A. Section C. – Who Is An Insured is amended to include as an additional insured the person(s) or organization(s) shown in the Schedule, but only with respect to liability for "bodily injury", "property damage" or "personal and advertising injury" caused, in whole or in part, by:

1. Your acts or omissions; or
2. The acts or omissions of those acting on your behalf;

in the performance of your ongoing operations for the additional insured(s) at the location(s) designated above.

B. With respect to the insurance afforded to these additional insureds, the following additional exclusions apply:

This insurance does not apply to "bodily injury" or "property damage" occurring after:

1. All work, including materials, parts or equipment furnished in connection with such work, on the project (other than service, maintenance or repairs) to be performed by or on behalf of the additional insured(s) at the location of the covered operations has been completed; or
2. That portion of "your work" out of which the injury or damage arises has been put to its intended use by any person or organization other than another contractor or subcontractor engaged in performing operations for a principal as a part of the same project.



THIS ENDORSEMENT CHANGES THE POLICY. PLEASE READ IT CAREFULLY.

POLICY CHANGE

This endorsement changes the policy effective on the Inception Date of the policy unless another date is indicated below:

Policy Number: 57 SBA AX4777 SC

Named Insured and Mailing Address; COMMUNITY DEVELOPMENT SERVICES, INC

3895 MAIN ST
KELSEYVILLE CA 95451

Policy Change Effective Date: 04/18/21

**Effective hour is the same as stated in the
Declarations Page of the Policy.**

Policy Change Number: 001

Agent Name: LINCOLN-LEAVITT INS AGENCY INC
Code: 128971

POLICY CHANGES:

SENTINEL INSURANCE COMPANY, LIMITED

ANY CHANGES IN YOUR PREMIUM WILL BE REFLECTED IN YOUR NEXT BILLING STATEMENT. IF YOU ARE ENROLLED IN REPETITIVE EFT DRAWS FROM YOUR BANK ACCOUNT, CHANGES IN PREMIUM WILL CHANGE FUTURE DRAW AMOUNTS.

THIS IS NOT A BILL.

NO PREMIUM DUE AS OF POLICY CHANGE EFFECTIVE DATE

BUSINESS LIABILITY OPTIONAL COVERAGES ARE REVISED

ADDITIONAL INSURED(S) ARE ADDED
THE FOLLOWING ARE ADDITIONAL INSURED FOR BUSINESS LIABILITY COVERAGE IN THIS POLICY.

LOCATION 001 BUILDING 001

SEE FORM IH 12 00

FORM NUMBERS OF ENDORSEMENTS ADDED AT ENDORSEMENT ISSUE:
PRO RATA FACTOR: 1.000

THIS ENDORSEMENT DOES NOT CHANGE THE POLICY EXCEPT AS SHOWN.

Form SS 12 11 04 05 T
Process Date: 03/29/21

Page 001 (CONTINUED ON NEXT PAGE)
Policy Effective Date: 04/18/21
Policy Expiration Date: 04/18/22

POLICY CHANGE (Continued)

Policy Number: 57 SBA AX4777

Policy Change Number: 001

IH12001185 ADDITIONAL INSURED-OWNERS, LESSEES OR

CONTRACTORS - SCHEDULED PERSON OR ORGANIZATION

POLICY NUMBER: 57 SBA AX4777



THIS ENDORSEMENT CHANGES THE POLICY. PLEASE READ IT CAREFULLY.

ADDITIONAL INSURED-OWNERS, LESSEES OR
CONTRACTORS - SCHEDULED PERSON OR ORGANIZATION

LOC 001 BLDG 001
THE CITY OF FORT BRAGG, INCLUDING ITS OFFICERS, OFFICIALS, EMPLOYEES
AND VOLUNTEERS
416 N. FRANKLIN STREET
FORT BRAGG, CA 95437
RE: NUMBER OF JOB LOCATIONS: 1
DESCRIPTION OF COMPLETED OPERATIONS: CONSULTING SERVICES PROVIDED
REGARDING THE HCD CDBG GRANT PROGRAMS

FOR CONSULTANT CONTRACTS ONLY

WORKERS' COMPENSATION DECLARATION

I hereby affirm under penalty of perjury one of the following declarations:

I have and will maintain a certificate of consent to self-insure for workers' compensation, as provided for by Section 3700 of the Labor Code, for the performance of work for which this contract is issued.

I have and will maintain workers' compensation insurance, as required by Section 3700 of the Labor Code, for the performance of the work for which this contract is issued. My workers' compensation insurance carrier and policy number are:

Carrier _____

Policy Number _____ Exp. Date: _____

Name of Agent: _____ Phone No.: _____

I certify that, in the performance of the work for which this contract is issued, I shall not employ any person in any manner so as to become subject to the workers' compensation laws of California, and agree that, if I should become subject to the workers' compensation provisions of Section 3700 of the Labor Code, I shall forthwith comply with those provisions.

Date: 3/31/2021

Consultant: 

WARNING: FAILURE TO SECURE WORKERS' COMPENSATION COVERAGE IS UNLAWFUL, AND SHALL SUBJECT AN EMPLOYER TO CRIMINAL PENALTIES AND CIVIL FINES UP TO ONE HUNDRED THOUSAND DOLLARS (\$100,000), IN ADDITION TO THE COST OF COMPENSATION, DAMAGES AS PROVIDED FOR IN SECTION 3706 OF THE LABOR CODE, INTEREST, AND ATTORNEY'S FEES.

EXHIBIT C

**CITY OF FORT BRAGG
416 Franklin Street
Fort Bragg, California 95437**

**REQUIRED CONTRACT PROVISIONS
for CDBG-Aided Consultant Contracts**

Table of Contents

Section	Page
1. General Provisions	27
2. Conflict of Interest Provisions	28
3. Affirmative Action.....	28
4. Non Discrimination Clause	28
5. Section 3 Clauses.....	28
6. Equal Opportunity.....	29
7. Rehabilitation Act of 1973 and the “504 Coordinator”	31
8. Disadvantaged/Minority/Women Business Enterprise(DBE/WBE) Clauses	31
9. Copeland “Anti-Kickback” Act	32
10. Clean Air Act and Clean Water Act.....	32
11. Energy Policy and Conservation Act	32
12. Prevailing Wages.....	32
13. Sections 103 and 107 Contract Work Hours and Safety Standards Act	32
14. Bonus or Commission, Prohibition Against Payments of.....	33
15. Labor Standards—Federal Labor Standards Provisions	33
16. Labor Standards—State Labor Standards Provisions	33
17. Anti-lobbying, Consultant's/Sub-consultant's Certification Concerning	34
Forms Included:	
1. Disadvantaged/Minority/Women Business Enterprise (DBE/WBE)	35
2. Consultant's/Sub-Consultant's Certification Concerning Anti-Lobbying	36
3. Disclosure of Lobbying Activities.....	37
4. Consultant's Certification Concerning Conflict of Interest	40
5. Certification Regarding Debarment, Suspension, Ineligibility and Voluntary Exclusion Lower Tier Covered Transactions	41

1. General Provisions

- 1.1 This project is funded wholly or in part by the State of California Community Development Block Grant Program and is subject to both Federal and State regulatory requirements. The consultant and its sub-contractors agree to comply with all State and Federal laws and regulations that pertain to construction, health and safety, labor, fair employment practices, equal opportunity, and all other matters applicable to the Consultant and any subcontractors. The consultant further agrees to comply with all Federal laws and regulations applicable to the CDBG Program and with other Federal provisions as set forth below.
- 1.2 These contract provisions shall apply to all work performed on the contract by the consultant's own organization and with the assistance of workers under the consultant's immediate superintendence and to all work performed on the contract by piecework, station work, or by subcontract.
- 1.3 Except as otherwise provided for in each section, the consultant shall insert in each subcontract all of the stipulations contained in these Required Contract Provisions for CDBG-Aided Consultant Contracts, and further require their inclusion in any lower tier subcontract or purchase order that may in turn be made. The Required Contract Provisions for CDBG-Aided Consultant Contracts shall not be incorporated by reference in any case. The prime consultant shall be responsible for compliance by any sub-consultant or lower tier sub-consultant with these Required Contract Provisions for CDBG-Aided Consultant Contracts.
- 1.4 The consultant and its sub-consultants shall perform the project in accordance with Federal, State and local housing and building codes as are applicable.
- 1.5 All data and design and engineering work created under this Agreement shall be owned by the Subgrantee / owner of the subject property and shall not be subject to copyright protection. The rights to any invention which is developed in the course of this Agreement shall be the property of the Subgrantee/subject property owner.
- 1.6 The consultant and its sub-consultants shall maintain at least the minimum State-required Worker's Compensation Insurance for those employees who will perform the contract activity(ies) or any part of it.
- 1.7 The consultant and its sub-consultants shall maintain, if so required by law, unemployment insurance, disability insurance and liability insurance in an amount to be determined by the State which is reasonable to compensate any person, firm, or corporation who may be injured or damaged by the consultant or any sub-consultant in performing the project or any part of it.
- 1.8 The consultant and its sub-consultants shall retain all books, records, accounts, documentation, and all other materials relevant to the agreement for a period of five (5) years from date of termination of the agreement, or five (5) years from the conclusion or resolution of any and all audits or litigation relevant to the agreement and any amendments, whichever is later.
- 1.9 The consultant and its sub-consultants shall permit the State, Federal government, the Bureau of State Audits, the Department of Housing and Community Development, the City of Fort Bragg and/or their representatives, upon reasonable notice, unrestricted access to any or all books, records, accounts, documentation, and all other materials

relevant to the agreement for the purpose of monitoring, auditing, or otherwise examining said materials.

2. Conflict of Interest Provisions.

2.1 Conflict of Interest of Members, Officers, or Employees of Consultants, Members of Local Governing Body, or other Public Officials

Pursuant to 24 CFR 570.611, no member, officer, or employee of the Consultant, or its designees or agents, no member of the governing body of the locality in which the program is situated, and no other public official of such locality or localities who exercise or have exercised any functions or responsibilities with respect to CDBG activities assisted under this part, or who are in a position to participate in a decision-making process or gain inside information with regard to such activities, may obtain a financial interest or benefit from a CDBG-assisted activity, or have a financial interest in any contract, subcontract or agreement with respect to a CDBG-assisted activity or its proceeds, either for themselves or those with whom they have business or immediate family ties, during their tenure or for one (1) year thereafter.

2.2 Conflict of Interest of Certain Federal Officials

No member of or delegate to the Congress of the United States, and no resident commissioner, shall be admitted to any share or part of this Agreement or to any benefit to arise from the same.

3. Affirmative Action:

The work to be performed under this contract is on a project assisted under a program providing direct federal financial assistance from the United States Department of Housing and Urban Development (HUD) and subject to 24 CFR 85.36(e). All bidders are notified that the CDBG grantee and all sub-grantees will affirmatively insure that in any contract entered into pursuant to this advertisement, disadvantaged, minority and women's business enterprises will be afforded full opportunity to submit bids in response to this invitation and will not be discriminated against on the grounds of race, color, religious creed, sex, or nation origin in consideration for an award. Minority and women-owned and operated businesses are encouraged to apply.

4. Non Discrimination Clause

The Civil Rights, Housing and Community Development, and Age Discrimination Acts Assurances:

During the performance of this Agreement, the Consultant assures that no otherwise qualified person shall be excluded from participation or employment, denied program benefits, or be subjected to discrimination based on race, color, national origin, sex, age, handicap, religion, familial status, or religious preference, under any program or activity funded by this contract, as required by Title VI of the Civil Rights Act of 1964, Title I of the Housing and Community Development Act of 1974, as amended, the Age Discrimination Act of 1975, the Fair Housing Amendment Act of 1988, and all implementing regulations.

5. Section 3 Clauses: The Training, Employment, and Contracting Opportunities for Business and Lower Income Persons Assurance of Compliance

- 5.1 The work to be performed under this Agreement is on a project assisted under a program providing direct Federal financial assistance from the Department of Housing and Urban Development and is subject to the requirements of Section 3 of the Housing and Urban Development Act of 1968, as amended, 12 U.S.C. 1701u. Recipients, contractors and subcontractors shall direct their efforts to provide, to the greatest extent feasible, training and employment opportunities generated from the expenditure of Section 3 covered assistance to Section 3 residents in other order of priority provided in 24 CFR 135.34(a)(2).
- 5.2 The parties to this Agreement will comply with the provisions of said Section 3 and the regulations issued pursuant thereto by the Secretary of Housing and Urban Development set forth in 24 CFR Part 135, and all applicable rules and orders of the Department issued thereunder prior to the execution of this contract. The parties to this contract certify and agree that they are under no contractual or other disability which would prevent them from complying with these requirements.
- 5.3 The consultant will include these Section 3 clauses in every contract and subcontract for work in connection with the project and will, at the direction of the State or City, take appropriate action pursuant to the contract upon a finding that any consultant or sub-consultant is in violation of regulations issued by the Secretary of Housing and Urban Development, 24 CFR Part 135 and will not let any contract unless the Consultant or consultant or sub-consultant has first provided it with a preliminary statement of ability to comply with the requirements of these regulations.
- 5.4 Compliance with the provisions of Section 3, the regulations set forth in 24 CFR Part 135, and all applicable rules and orders of the Department issued thereunder prior to the execution of the Agreement shall be a condition of the Federal financial assistance provided to the project, binding upon the consultant, its successors, and assigns. Failure to fulfill these requirements shall subject the consultant and its sub-consultants, its successors, and assigns to those sanctions specified by the grant or contract through which Federal assistance is provided, and to such sanctions as are specified by 24 CFR Part 135.

6. Equal Opportunity

During the performance of this Contract, the Contractor agrees as follows:

- 6.1 The Contractor with comply with Executive Order 11246 of September 24, 1965 entitled Equal Employment Opportunity as amended by Executive Order 11375 of October 1967 as supplemented in Department of Labor regulations (41 CFR chapter 60).
- 6.2 The Contractor will not discriminate against any employee or applicant for employment because of race, color, religion, sex, or national origin. The Contractor will take affirmative action to insure that applicants are employed and that employees are treated equally during employment, without regard to race, color, religion, sex, or national origin. Such action shall include, but not be limited to, the following: employment upgrading, demotion, transfer, recruitment, or recruitment advertising; layoff or termination; rates of pay or other forms of compensation; and selection for training including apprenticeship. The Contractor agrees to post in conspicuous places, available to employees and applicants for employment, notices to be provided by the City Setting forth the provisions of this nondiscrimination clause.

- 6.3 The Contractor will, in all solicitations or advertisements for employees placed by or on behalf of the Contractor, state that all qualified applicants will receive consideration for employment without regard to their race, color, religion, sex, or national origin.
- 6.4 The Contractor will send to each labor union or representative of workers with which he has a collective bargaining agreement or other contract or understanding, a notice, to be provided by the agency contracting officer, advising the labor union or workers' representative of the contractor's commitments under Section 202 of Executive Order No. 11246 of September 24, 1965, and shall post copies of the notice in conspicuous places available to employees and applicants for employment.
- 6.5 The Contractor will furnish all information and reports required by Executive Order No. 11246 of September 24, 1965, and by the rules, regulations, and orders of the Secretary of Labor, or pursuant thereto, and will permit access to his books, records, and accounts by the contracting agency and the Secretary of Labor for purposes of investigation to ascertain compliance with such rules, regulations, and orders.
- 6.6 In the event of the Contractor's noncompliance with the nondiscrimination clauses of this contract or with any of such rules, regulations, or orders, this contract may be cancelled, terminated or suspended in whole or in part and the contractor may be declared ineligible for further Government contracts in accordance with procedures authorized in Executive Order No.11246 of Sept. 24, 1965, and such other sanctions may be imposed and remedies invoked as provided in Executive Order No.11246 of September 24, 1965, or by rule, regulation, or order of the Secretary of Labor, or as otherwise provided by law.
- 6.7 The Contractor will include the provisions of paragraphs (1) through (7) in every subcontract or purchase order unless exempted by rules, regulations, or orders of the Secretary of Labor issued pursuant to Section 204 of Executive Order No. 11246 of September 24, 1965, so that such provisions will be binding upon each subcontractor or vendor. The contractor will take such action with respect to any subcontract or purchase order as may be directed by the Secretary of Labor as a means of enforcing such provisions including sanctions for noncompliance: Provided, however, that in the event the contractor becomes involved in, or is threatened with, litigation with a subcontractor or vendor as a result of such direction, the contractor may request the United States to enter into such litigation to protect the interests of the United States.
- 6.8 The Contractor shall file, and shall cause each of his subcontractors to file, Compliance Reports with the contracting agency or the Secretary of Labor as may be directed. Compliance Reports shall be filed within such times and shall contain such information as to the practices, policies, programs, and employment policies, programs, and employment statistics of the contractor and each subcontractor, and shall be in such form, as the Secretary of Labor may prescribe.
- 6.9 Bidders or prospective contractors or subcontractors may be required to state whether they have participated in any previous contract subject to the provisions of this Order, or any preceding similar Executive order, and in that event to submit, on behalf of themselves and their proposed subcontractors, Compliance Reports prior to or as an initial part of their bid or negotiation of a contract.
- 6.10 Whenever the Contractor or subcontractor has a collective bargaining agreement or other Contract or understanding with a labor union or an agency referring workers or providing or supervising apprenticeship or training for such workers, the Compliance Report shall include such information as to such labor union's or agency's practices and policies affecting compliance as the Secretary of Labor may prescribe: Provided, That to the

extent such information is within the exclusive possession of a labor union or an agency referring workers or providing or supervising apprenticeship or training and such labor union or agency shall refuse to furnish such information to the contractor, the contractor shall so certify to the Secretary of Labor as part of its Compliance Report and shall set forth what efforts he has made to obtain such information.

- 6.11 The Secretary of Labor may direct that any bidder or prospective contractor or subcontractor shall submit, as part of his Compliance Report, a statement in writing, signed by an authorized officer or agent on behalf of any labor union or any agency referring workers or providing or supervising apprenticeship or other training, with which the bidder or prospective contractor deals, with supporting information, to the effect that the signer's practices and policies do not discriminate on the grounds of race, color, religion, sex or national origin, and that the signer either will affirmatively cooperate in the implementation of the policy and provisions of this order or that it consents and agrees that recruitment, employment, and the terms and conditions of employment under the proposed contract shall be in accordance with the purposes and provisions of the order. In the event that the union or the agency shall refuse to execute such a statement, the Compliance Report shall so certify and set forth what efforts have been made to secure such a statement and such additional factual material as the Secretary of Labor may require.
- 6.12 The Contractor will cause the foregoing provisions to be inserted in all subcontracts for work covered by this Agreement so that such provisions will be binding upon each subcontractor, provided that the foregoing provisions shall not apply to contracts or subcontracts for standard commercial supplies or raw materials.

7. Rehabilitation Act of 1973 and the "504 Coordinator"

The Consultant further agrees to implement the Rehabilitation Act of 1973, as amended, and its regulations, 24 CFR Part 8, including, but not limited to, for Consultants with fifteen(15) or more permanent full or part time employees, the local designation of a specific person charged with local enforcement of this Act, as the "504 Coordinator."

8. Disadvantaged/Minority/Women Business Enterprise Federal Regulatory Requirements Under 24 CFR 85.36(e):

The Contractor will take all necessary affirmative steps to assure that minority firms, women's business enterprises, and labor surplus area firms are used when possible.

Affirmative steps shall include:

- 8.1 Placing qualified small and minority businesses and women's business enterprises on solicitation lists;
- 8.2 Assuring that small and minority businesses, and women's business enterprises are solicited whenever they are potential sources;
- 8.3 Dividing total requirements, when economically feasible, into smaller tasks or quantities to permit maximum participation by small and minority business, and women's business enterprises;
- 8.4 Establishing delivery schedules, where the requirement permits, which encourage participation by small and minority business, and women's business enterprises;

8.5 Using the services/assistance of the Small Business Administration (SBA), and the Minority Business Development Agency (MBDA) of the Department of Commerce.

9. Copeland "Anti-Kickback" Act (18 U.S.C. 874)

Contractor shall comply with the Copeland "Anti-Kickback" Act (18 U.S.C. 874) as supplemented in Department of Labor regulations (29 CFR Part 3).

10. Compliance with Clean Air Act and Clean Water Act.

Contractor shall comply with all applicable standards, orders and requirements issued under Section 306 of the Clean Air Act (42 U.S.C. 1857(h)).

10.1 Contractor shall comply with all applicable standards, orders and requirements issued under Section 508 of the Clean Air Act (33 U.S.C. 1368).

10.2 Contractor shall comply with Executive Order 11738 and Environmental Protection Agency regulations (40 CFR Part 15).

11. Compliance with Energy Policy and Conservation Act (Pub. L. 94-163, 89 Stat. 871)

The Contractor shall comply with the mandatory standards and policies relating to energy efficiency which are contained in the state energy conservation plan issued in compliance with the Energy Policy and Conservation Act (Pub. L. 94-163, 89 Stat. 871).

12. Prevailing Wages

12.1 Where funds provided through this Agreement are used for construction work, or in support of construction work, the Consultant shall ensure that the requirements of California Labor Code (LC), Chapter 1, commencing with Section 1720, Part 7 (pertaining to the payment of prevailing wages and administered by the California Department of Industrial Relations) are met.

12.2 For the purposes of this requirement "construction work" includes, but is not limited to rehabilitation, alteration, demolition, installation or repair done under contract and paid for, in whole or in part, through this Agreement. All construction work shall be done through the use of a written contract with a properly licensed building contractor incorporating these requirements (the "construction contract"). Where the construction contract will be between the Consultant and a licensed building contractor, the Consultant shall serve as the "awarding body" as that term is defined in the Labor Code. Where the Consultant will provide funds to a third party that will enter into the construction contract with a licensed building contractor, the third party shall serve as the "awarding body." Prior to any disbursement of funds, including but not limited to release of any final retention payment, the Department may require a certification from the awarding body that prevailing wages have been or will be paid.

13. Compliance with Sections 103 and 107 of the Contract Work Hours and Safety Standards Act (40 U.S.C. 327-330)

Contractor will comply with Sections 103 and 107 of the Contract Work Hours and Safety Standards Act (40 U.S.C. 327-330) as supplemented by Department of Labor regulations (29 CFR part 5). Requires the contracting officer to insert the clauses set forth in 29 CFR Part 5, Construction contracts awarded by grantees and subgrantees in excess of \$2000, and in excess of \$2500 for other contracts which involve the employment of mechanics or laborers).

14. Bonus or Commission, Prohibition Against Payments of

The assistance provided under this Agreement shall not be used in the payment of any bonus or commission for the purpose of:

- A. Obtaining the Department's approval of the application for such assistance; or
- B. The Department's approval of the applications for additional assistance; or
- C. Any other approval or concurrence of the Department required under this Agreement, Title I of the Housing and Community Development Act of 1974, or the State regulations with respect thereto; provided, however, that reasonable fees for bona fide technical, consultant, managerial or other such services, other than actual solicitation, are not hereby prohibited if otherwise eligible as program costs.

15. Labor Standards—Federal Labor Standards Provisions

Contractor shall comply with all provisions contained in the form HUD-1040, Federal Labor Standards Provisions. The Consultant shall cause or require to be inserted in full, in all such contracts subject to such regulations, provisions meeting the requirements of:

- 15.1 Davis-Bacon Act (40 U.S.C. 3141-3148) requires that workers receive no less than the prevailing wages being paid for similar work in their locality. Prevailing wages are computed by the Department of Labor and are issued in the form of federal wage decisions for each classification of work. The law applies to most construction, alteration, or repair contracts over \$2,000.
- 15.2 “Anti-Kickback Act of 1986” (41 U.S.C. 51-58) prohibits any person from:
 - (1) providing, attempting to provide, or offering to provide any kickback;
 - (2) soliciting, accepting, or attempting to accept any kickback; or
 - (3) including directly or indirectly, the amount of any kickback prohibited by clause (1) or (2) in the contract price charged by a subcontractor to a prime contractor or a higher tier subcontractor or in the contract price charged by a prime contractor to the United States.
- 15.3 Contract Work Hours and Safety Standards Act - CWHSSA (40 U.S.C. 3702) requires that workers receive “overtime” compensation at a rate of one to one-half (1-1/2) times their regular hourly wage after they have worked forty (40) hours in one week.
- 15.4 Title 29, Code of Federal Regulations, Subtitle A, Parts I, 3 and 5 are the regulations and procedures issued by the Secretary of Labor for the administration and enforcement of the Davis-Bacon Act, as amended.

16. Labor Standards—State Labor Standards Provisions

State prevailing wage rates shall apply when the State wage rate is higher than the Federal wage rate. All contractors and subcontractors are subject to the application of Section 1720 et seq. of the California Labor Code which details the regulations and procedures governing the payment of State prevailing wages.

All contractors and subcontractors are subject to the provisions of Section 3700 of the California Labor Code which requires that every employer be insured against liability for workers' compensation or to undertake self-insurance in accordance with the provisions of the code.

All contractors and subcontractors are subject to the provisions of Sections 1810-1814 of the California Labor Code which provide that the maximum hours a worker is to be employed is limited to eight hours a day and 40 hours a week and the contractor or subcontractor shall forfeit, as a penalty, \$25 for each worker employed in the execution of the contract for each calendar day during which a worker is required or permitted to labor more than eight hours in any calendar day or more than 40 hours in any calendar week and is not paid overtime.

Section 1815 of the California Labor Code requires that notwithstanding the provisions of Sections 1810-1814, employees of contractors who work in excess of eight hours per day and 40 hours per week shall be compensated for all hours worked in excess of eight hours per day at not less than 1½ times the basic rate of pay.

17. Anti-Lobbying Certification

The consultant shall require that the language included in the Consultant's/Sub-consultant's Certification concerning Anti-Lobbying form be included in all subcontracts entered into in connection with this activity and that consultant and all subconsultants shall certify and disclose per the requirements of that form.

CITY OF FORT BRAGG
416 North Franklin Street
Fort Bragg, California 95437

**DISADVANTAGED/MINORITY/WOMEN BUSINESS ENTERPRISE FEDERAL
REGULATORY REQUIREMENTS UNDER 24 CFR 85.36(E)**

Pursuant to HUD reporting requirements for CDBG recipients and subrecipients, all contractors and subcontractors must submit the following information to the City of Fort Bragg for annual CDBG reporting:

1. Is Consultant's business Women Owned? Yes No

A woman-owned business enterprise (WBE) is defined as a business that is at least 51% owned, operated and controlled on a daily basis by one or more (in combination) female American citizens.

2. Is Consultant's business a Section 3 Business? Yes No

Section 3 businesses are those that can provide evidence of meeting one of the following three criteria:

- a) 51 percent or more owned by Section 3 residents; or
- b) At least 30 percent of its full time employees include persons that are currently Section 3 residents, or were Section 3 residents within three years of the date of first hire*; or
- c) Provides evidence, as required, of a commitment to subcontract in excess of 25 percent of the dollar award of all subcontracts to businesses that meet the qualifications of a) or b) above.

3. Consultant's Employer Identification Number: 91-184-1998

4. Consultant's business Racial/Ethnic Code: 11

CODES:

- | | |
|--|---|
| 11-White | 16-American Indian/Alaskan Native & White |
| 12-Black/African American | 17-Asian & White |
| 13-Asian | 18-Black/African American & White |
| 14-American Indian/Alaskan American
Black/African Amer. | 19-American Indian/Alaskan Native & |
| 15-Native Hawaiian/other Pacific Islander | 20-Other Multi-Racial |

5. Will any subcontractors be hired by consultant in order to accomplish the contract scope of work? Yes No

If YES, list known subcontractors: _____
(use additional page if needed)

If YES, a copy of this form must be provided to each subcontractor and submitted to the City of Fort Bragg within 10 days of contract/subcontract date.

Signed _____
(Contractor representative)

Company name: _____

By: _____
(Print Name and Title)

Date: _____

CITY OF FORT BRAGG
416 North Franklin Avenue
Fort Bragg, California 95437

CONSULTANT'S/SUB-CONSULTANT'S CERTIFICATION
CONCERNING ANTI-LOBBYING

The Consultant shall require that the language of this certification be included in all contracts or subcontracts entered into in connection with this grant activity(ies) and that all subrecipients shall certify and disclose accordingly. This certification is a material representation of fact upon which reliance was placed when this transaction was made or entered into. Submission of this certification is a prerequisite for making or entering into this transaction imposed by 31 U.S.C. 1352. Any person who fails to file the required certification shall be subject to a civil penalty of not less than \$10,000 and no more than \$100,000 for such failure. "The undersigned certifies, to the best of his or her knowledge or belief, that:

A. No Federal appropriated funds have been paid or will be paid, by or on behalf of it, to any person for influencing or attempting to influence an officer or employee of any agency, a Member of Congress, an officer or employee of Congress, or an employee of a Member of Congress in connection with the awarding of any Federal contract, the making of any Federal grant, the making of any Federal loan, the entering into of any cooperative agreement, and the extension, continuation, renewal, amendment, or modification of any Federal contract, grant, loan, or cooperative agreement;

B. If any funds other than Federal appropriated funds have been paid or will be paid to any person for influencing or attempting to influence an officer or employee of any agency, a Member of Congress, an officer or employee of Congress, or an employee of a Member of Congress in connection with this Federal contract, grant, loan, or cooperative agreement, it will complete and submit the "Disclosure of Lobbying Activities" form in accordance with its instructions.

(Consultant/Sub-consultant)

By

Signature

Jeff Lucas, Principal

Typed Name and Title

Date

3/25/2021

INSTRUCTIONS FOR COMPLETION OF DISCLOSURE OF LOBBYING ACTIVITIES FORM

This disclosure form shall be completed by the reporting entity, whether subawardee or prime Federal recipient, at the initiation or receipt of covered Federal action or a material change to previous filing pursuant to title 31 U.S.C. Section 1352. The filing of a form is required for such payment or agreement to make payment to lobbying entity for influencing or attempting to influence an officer or employee of any agency, a Member of Congress an officer or employee of Congress or an employee of a Member of Congress in connection with a covered Federal action. Attach a continuation sheet for additional information if the space on the form is inadequate. Complete all items that apply for both the initial filing and material change report. Refer to the implementing guidance published by the Office of Management and Budget for additional information.

1. Identify the type of covered Federal action for which lobbying activity is and/or has been secured to influence, the outcome of a covered Federal action.
2. Identify the status of the covered Federal action.
3. Identify the appropriate classification of this report. If this is a follow-up report caused by a material change to the information previously reported, enter the year and quarter in which the change occurred. Enter the date of the last, previously submitted report by this reporting entity for this covered Federal action.
4. Enter the full name, address, city, State and zip code of the reporting entity. Include Congressional District if known. Check the appropriate classification of the reporting entity that designates if it is or expects to be a prime or subaward recipient. Identify the tier of the subawardee, e.g., the first subawardee of the prime is the first tier. Subawards include but are not limited to subcontracts, subgrants and contract awards under grants.
5. If the organization filing the report in Item 4 checks "Subawardee" then enter the full name, address, city, State and zip code of the prime Federal recipient. Include Congressional District, if known.
6. Enter the name of the Federal agency making the award or loan commitment. Include at least one organization level below agency name, if known. For example, Department of Transportation, United States Coast Guard.
7. Enter the Federal program name or description for the covered Federal action (item 1). If known, enter the full Catalog of Federal Domestic Assistance (CFDA) number for grants, cooperative agreements, loans and loan commitments.
8. Enter the most appropriate Federal identifying number available for the Federal action identification in item 1 (e.g., Request for Proposal (RFP) number, Invitation for Bid (IFB) number, grant announcement number, the contract grant. or loan award number, the application/proposal control number assigned by the Federal agency). Include prefixes, e.g., "RFP-DE-90-001."
9. For a covered Federal action where there has been an award or loan commitment by the Federal agency, enter the Federal amount of the award/loan commitments for the prime entity identified in item 4 or 5.
10. (a) Enter the full name, address, city, State and zip code of the lobbying entity engaged by the reporting entity identified in item 4 to influence the covered Federal action.

- (b) Enter the full names of the individual(s) performing services and include full address if different from 10 (a). Enter Last Name, First Name and Middle Initial (MI).
11. Enter the amount of compensation paid or reasonably expected to be paid by the reporting entity (item 4) to the lobbying entity (item 10). Indicate whether the payment has been made (actual) or will be made (planned). Check all boxes that apply. If this is a material change report, enter the cumulative amount of payment made or planned to be made.
 12. Check the appropriate box(es). Check all boxes that apply. If payment is made through an in-kind contribution, specify the nature and value of the in-kind payment.
 13. **Check the appropriate box(es). Check all boxes that apply. If other, specify nature.**
 14. Provide a specific and detailed description of the services that the lobbyist has performed or will be expected to perform and the date(s) of any services rendered. Include all preparatory and related activity not just time spent in actual contact with Federal officials. Identify the Federal officer(s) or employee(s) contacted or the officer(s) employee(s) or Member(s) of Congress that were contacted.
 15. Check whether or not a continuation sheet(s) is attached.
 16. The certifying official shall sign and date the form, print his/her name title and telephone number.

Public reporting burden for this collection of information is estimated to average 30 minutes per response, including time for reviewing instruction, searching existing data sources, gathering and maintaining the data needed, and completing and reviewing the collection of information. Send comments regarding the burden estimate or any other aspect of this collection of information, including suggestions for reducing this burden, to the Office of Management and Budget, Paperwork Reduction Project (0348-0046), Washington, D.C. 20503.

CITY OF FORT BRAGG
416 North Franklin Avenue
Fort Bragg, California 95437

**CONSULTANT'S CERTIFICATION
CONCERNING CONFLICT OF INTEREST**

By submitting its proposal the consultant certifies as follows:

I am aware and in compliance with the following provisions regarding Conflict of Interest of Consultants:

1. Conflict of Interest of Members, Officers, or Employees of Contractors, Members of Local Governing Body, or other Public Officials

Pursuant to 24 CFR 570.611, no member, officer, or employee of the City, or its designees or agents, no member of the governing body of the locality in which the project is situated, and no other public official of such locality or localities who exercise or have exercised any functions or responsibilities with respect to CDBG activities assisted under this part, or who are in a position to participate in a decision-making process or gain inside information with regard to such activities, may obtain a financial interest or benefit from a CDBG-assisted activity, or have a financial interest in any contract, subcontract or agreement with respect to a CDBG-assisted activity or its proceeds, either for themselves or those with whom they have business or immediate family ties, during their tenure or for one (1) year thereafter.

2. Conflict of Interest of Certain Federal Officials

No member of or delegate to the Congress of the United States, and no resident commissioner, shall be admitted to any share or part of this Contract or to any benefit to arise from the same.

Signed _____
(Consultant)

By Jeff Lucas, Principal
Print Name and Title

Date: 3/25/2021

STATE OF CALIFORNIA
Department of Housing and Community Development
COMMUNITY DEVELOPMENT BLOCK GRANT (CDBG) Program

**CERTIFICATION REGARDING DEBARMENT, SUSPENSION,
 INELIGIBILITY AND VOLUNTARY EXCLUSION LOWER TIER COVERED TRANSACTIONS**

This certification is required by the regulations implementing Executive Order 12549, Debarment and Suspension, 24 CFR Part 85, Section 85.510, Participants' responsibilities. The regulations were published as Part VII of the May 26, 1988 Federal Register (pages 19160-19211).

(BEFORE COMPLETING THIS CERTIFICATION, READ INSTRUCTIONS BELOW)

- (1) The prospective lower tier participant certifies, by submission of this proposal, that neither it nor its principles are presently debarred, suspended, proposed for debarment, declared ineligible, or voluntarily excluded from participation in this transaction by any Federal department or agency.
- (2) Where the prospective lower tier participant is unable to certify to any of the statements in this certification, such prospective participant shall attach an explanation to this proposal.

Grant Number:

Name of Participant:

Address of Participant:

200 Main Street, Kelseyville CA 95451

Jeff Lucas, Principal

Name and Title of Authorized Representative

[Signature]

Signature

3/25/0021

Date

1. By signing and submitting this proposal, the prospective lower tier participant is providing the certification set out below.
2. The certification in this clause is a material representation of fact upon which reliance was placed when this transaction was entered into. If it is later determined that the prospective lower tier participant knowingly rendered an erroneous certification, in addition to other remedies available to the Federal Government, the department or agency with which this transaction originated may pursue available remedies, including suspension and/or debarment.
3. The prospective lower tier participant shall provide immediate written notice to the person to whom this proposal is submitted if at any time the prospective lower tier participant learns that its certification was erroneous when submitted or has become erroneous by reason of changed circumstances.
4. The terms "covered transaction", "debarred", "suspended", "ineligible", "lower tier covered transaction", "participant", "person", "primary covered transaction", "principal", "proposal", and "voluntarily excluded", as used in this clause, have the meanings set out in the Definitions and Coverage sections of rules implementing Executive Order 12549.
5. The prospective lower tier participant agrees by submitting this proposal that, should the proposed covered transaction be entered into, it shall not knowingly enter into any lower tier covered transaction with a person who is debarred, suspended, declared ineligible, or voluntarily excluded from participation in this covered transaction, unless authorized by the department or agency with which this transaction originated.
6. The prospective lower tier participant further agrees by submitting this proposal that it will include the clause titled "Certification Regarding Debarment, Suspension, Ineligibility and Voluntary Exclusion -- Lower Tier Covered Transactions", without modification, in all lower tier covered transactions and in all solicitations for lower tier covered transactions.
7. A participant in a covered transaction may rely upon a certification of a prospective participant in a lower tier covered transaction that is not debarred, suspended, ineligible, or voluntarily excluded from the covered transaction, unless it knows that the certification is erroneous. A participant may decide the method and frequency by which it determines the eligibility of its principals. Each participant may check the non-procurement List.
8. Nothing contained in the foregoing shall be construed to require establishment of a system of records in order to render in good faith the certification required by this clause. The knowledge and information of a participant is not required to exceed that which is normally possessed by a prudent person in the ordinary course of business dealings.
9. Except for transactions authorized under paragraph 5 of these instructions, if a participant in a covered transaction knowingly enters into a lower tier covered transaction with a person who is suspended, debarred, ineligible, or voluntarily excluded from participation in this transaction, in addition to other remedies available to the Federal Government, the department or agency with which this transaction originated may pursue available remedies, including suspension and/or debarment.

From: [Deborah Swartz](#)
To: [McLaughlin, Natalie](#); [Lemos, June](#)
Cc: ["Jeff Lucas"](#)
Subject: RE: E & O Insurance
Date: Tuesday, April 27, 2021 9:48:58 AM
Attachments: [E & O Insurance.pdf](#)

Good Morning,

Attached is the quote we received for the E & O Insurance. I will be signing the contract for the insurance hopefully today, and will send to you this task is completed. Please contact Jeff of I if you have any questions.

Sincerely,

Deborah

Deborah L. Swartz
Program Manager
Community Development Services
3895 Main Street
Kelseyville, CA 95451
(707) 279-1540 ex 102
(707) 953-3475 cell
deborahswartz@mediacombb.net

-----Original Message-----

From: Jeff Lucas <jefflucas@mchsi.com>
Sent: Monday, April 26, 2021 4:52 PM
To: 'Deborah Swartz' <deborahswartz@mediacombb.net>
Subject: Fort Bragg Contract

Deb,

Please send the amount of the cost for the \$1,000,000 coverage to Natalie and June. Natalie will make sure our contract is increased to cover the cost.

Thank you,

--

Jeff Lucas, Principal
Community Development Services
3895 Main Street
Kelseyville, CA 95451
707-279-1540
707-489-4943 cell
jefflucas@mchsi.com



PRODUCER: Lincoln-Leavitt Insurance Agency, Inc.
Lakeport , CA

FROM: Chris Laeng

ATTN: Jill Jensen

Quotation

We are pleased to offer the following Quotation obtained solely on the basis of your instructions to us. This Quotation may be withdrawn at any time prior to acceptance, and in no event will it remain open beyond 30 days from the date shown above. Coverage may not be bound without prior consent from the insurer as confirmed in writing by Brown & Riding.

Please note that the coverage, terms, and conditions described in this Quotation may differ from those requested in Producer's original submission. Producer is responsible for reviewing the suitability of coverage, terms, and conditions with the insured and for reconciling any differences between this Quotation and your original submission to us. Brown & Riding disclaims any responsibility for identifying or reconciling differences between this Quotation and Producer's original submission.

TERM: To be determined

INSURED: Parker, Lucas and Associates DBA Community Development Services

MAILING ADDRESS: 3895 Main Street
Kelseyville, CA 95451

COMPANY: Gemini Insurance Company

TERMS: All terms and conditions per carrier quote, policy forms, endorsements, exclusions and notices

Annual Premium	\$	3,449.00	
Broker fee	\$	200.00	Fully retained at inception
CA Surplus lines tax	\$	103.47	
CA Stamping fee	\$	8.62	
Total Gross Amount	\$	3,761.09	

COMMISSION: 12.00 % **Balance due in 20 Days**

25.0% MINIMUM RETAINED PREMIUM IN THE EVENT OF CANCELLATION. NO FLAT



City of Fort Bragg

416 N Franklin Street
Fort Bragg, CA 95437
Phone: (707) 961-2823
Fax: (707) 961-2802

Text File

File Number: 21-129

Agenda Date: 5/10/2021

Version: 1

Status: Consent Agenda

In Control: City Council

File Type: Resolution

Agenda Number: 5B.

Adopt City Council Resolution Approving Parcel Map for Minor Division 1-20 (DIV 1-20); Carlos and Heather Franco (owner/applicant); Minor Subdivision of a 22,989 Square Foot Parcel Into Three Parcels of 7,515, 7,793, and 7,681 Square Feet and Accepting the 10 Foot Wide Public Utility Easement as Shown on the Parcel Map

On November 12, 2020 the Planning Commission approved the Tentative Map for Div 1-20 with the conditions contained in the attached Resolution. The applicant has complied with all of the conditions required to approve the Parcel Map. This Resolution will authorize the recording of the Parcel Map and acknowledge acceptance of the Public Utility Easement as shown on said Parcel Map.

RESOLUTION NO. ____-2021

**RESOLUTION OF THE FORT BRAGG CITY COUNCIL
APPROVING PARCEL MAP FOR MINOR DIVISION 1-20 (DIV 1-20); CARLOS
AND HEATHER FRANCO (OWNER/APPLICANT); MINOR SUBDIVISION OF A
22,989 SQUARE FOOT PARCEL INTO THREE PARCELS OF 7,515, 7,793,
AND 7,681 SQUARE FEET AND ACCEPTING THE 10 FOOT WIDE PUBLIC
UTILITY EASEMENT AS SHOWN ON THE PARCEL MAP**

WHEREAS, The Fort Bragg Planning Commission conditionally approved the Tentative Map for Minor Subdivision 1-20 on November 12, 2020, with the following Special Conditions:

1. Prior to final of the building permit issued to relocate the existing residence, applicant shall install a fire hydrant at the end of Halsey Way, at a location to be approved by the Public Works Director.
2. Prior to occupancy of any residential unit in this subdivision, address numbers shall be placed in such a manner as to be visible from Halsey Way, and shall be placed on each residential unit in such a manner as to be visible from the access driveway. The minimum height of numbers to be used shall be three inches and contrasting color from basic background.
3. Prior to final of the building permit issued to relocate the existing residence, the applicant shall construct sidewalk across Halsey Way along the entire width of Halsey Way, as shown on the Tentative Map. An encroachment permit is required to construct the frontage improvements.
4. Prior to final of the building permit issued to relocate the existing residence, the applicant shall construct a permeable paved 22-foot driveway. An encroachment permit is required to construct the frontage improvements.
5. A private, non-exclusive easement for the shared driveway shall be shown on the recorded Parcel Map. Maintenance Agreements for the private driveway shall be recorded as part of the deed for each parcel.
6. Water, sewer, and drainage capacity fees (Municipal Code section 12.14.030) for each lot shall be paid prior to issuance of the first building permit for said lot, and a note stating such shall appear on the face of the Parcel Map for recordation.
7. Applicant shall pay all water and sewer connection fees in order to connect to the public utilities (Municipal Code section 14.14.020). Connection fees shall be paid and connections shall be made prior to finalization of the building permit issued to relocate the existing residence.

8. Private, non-exclusive utility easements for the private utilities shall be shown on the recorded Parcel Map. Maintenance Agreements for the private utilities shall be recorded as part of the deed for each parcel.
9. Prior to recordation of the Parcel Map, applicant must submit a Final Stormwater Control Plan, along with associated calculations and worksheets, to be approved by the Public Works Director or his/her designee.
10. Stormwater runoff shall be minimized via the incorporation of the selected site design measures in accordance with the approved Final Stormwater Control Plan.
11. Private Maintenance Agreements for the on-site storm water facilities shall be recorded as part of the Deed for each parcel. Drafts of these documents shall be submitted and approved prior to approval of the Parcel Map.
12. Prior to approval of a Final Map, the applicant shall submit a landscape plan for the approval of the Community Development Director that identifies an area for the planting of native, drought-tolerant trees or shrubs that will provide an equivalent quantity of habitat. The area of planting shall be based on the ultimate canopy/growth size of the specimens proposed. The area of planting may be split into multiple locations throughout the project site of no less than 300 SF each. Plantings proposed by the approved landscape plan shall be complete/installed prior to final inspection of a building permit on parcels where the plantings are proposed.

WHEREAS, in order for the City to access the Fire Hydrant required by Special Condition 1 and its connection to the Public Water System, a Public Utility Easement is necessary; and

WHEREAS, the applicant is dedicating the required 10 foot wide Public Utility Easement on the Parcel Map; and

WHEREAS, the Public Works Director has determined that all conditions of approval required prior to recordation have been met;

NOW, THEREFORE, BE IT RESOLVED that the City Council of the City of Fort Bragg does hereby accept the Public Utility Easement as shown on the Parcel Map; and

BE IT FURTHER RESOLVED that the City Council of the City of Fort Bragg does hereby approve Parcel Map 1-20 and authorizes the City Clerk to execute same.

The above and foregoing Resolution was introduced by Councilmember _____, seconded by Councilmember _____, and passed and adopted at a regular meeting of the City Council of the City of Fort Bragg held on the 10th day of May, 2021, by the following vote:

- AYES:**
- NOES:**
- ABSENT:**
- ABSTAIN:**

RECUSED:

BERNIE NORVELL
Mayor

ATTEST:

June Lemos, CMC
City Clerk

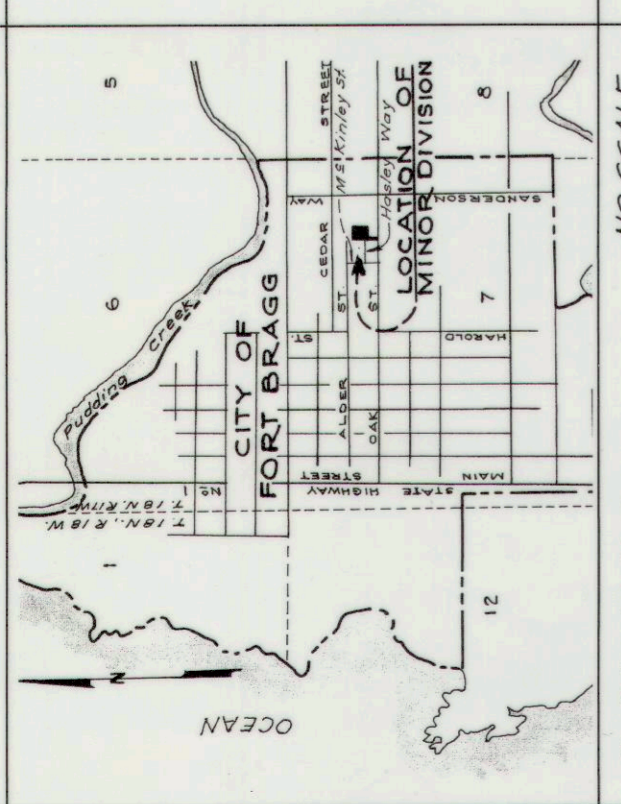

OWNER'S STATEMENT
 ME, THE UNDERSIGNED, BEING ALL PARTIES HAVING ANY RECORD TITLE INTEREST IN THE LAND WITHIN THIS DIVISION, HEREBY CONSENT TO THE PREPARATION AND RECORDATION OF THIS MAP AND HEREBY DEDICATE FOR PUBLIC USE THE FOLLOWING:
 1) A PUBLIC UTILITY EASEMENT AS SHOWN HEREON.

Carlos F. Franco
CARLOS F. FRANCO

Heather A. Franco
HEATHER A. FRANCO

ACKNOWLEDGMENT
 A NOTARY PUBLIC OR OTHER OFFICER COMPLETING THIS CERTIFICATE VERIFIES ONLY THE IDENTITY OF THE INDIVIDUAL WHO SIGNED THE DOCUMENT TO WHICH THIS CERTIFICATE IS ATTACHED, AND NOT THE TRUTHFULNESS ACCURACY OR VALIDITY OF THAT DOCUMENT.

STATE OF CALIFORNIA
 COUNTY OF MENDOCINO

ON 04-20-2021 BEFORE ME, **C. SOUTHERS**
 PERSONALLY APPEARED **CARLOS F. FRANCO** & **HEATHER A. FRANCO** WHO PROVIDED TO ME ON THE BASIS OF SATISFACTORY EVIDENCE TO BE THE PERSONS (WHOSE NAMES) IS ARE SUBSCRIBED TO THE WITHIN INSTRUMENT, AND ACKNOWLEDGED TO ME THAT HE/SHE/IT/ THEY EXECUTED ON THE SAME IN HIS/HER/THEIR AUTHORIZED CAPACITIES, AND THAT BY HIS/HER/THEIR SIGNATURE(S) ON THE INSTRUMENT THE PERSON(S), OR THE ENTITY UPON BEHALF OF WHICH THE PERSON(S) ACTED, EXECUTED THE INSTRUMENT.

I CERTIFY UNDER PENALTY OF PERJURY UNDER THE LAWS OF THE STATE OF CALIFORNIA THAT THE FOREGOING PARAGRAPH IS TRUE AND CORRECT.
 WITNESS MY HAND AND OFFICIAL SEAL.

SIGNATURE *Carlos F. Franco* (SEAL)

SURVEYOR'S STATEMENT
 THIS MAP WAS PREPARED BY ME OR UNDER MY DIRECTION AND IS BASED UPON A FIELD SURVEY IN CONFORMANCE WITH THE REQUIREMENTS OF THE SUBDIVISION MAP ACT AND LOCAL ORDINANCE IN THE REGARDS OF CARLOS F. FRANCO & HEATHER A. FRANCO. THE SURVEY WAS CONDUCTED IN ACCORDANCE WITH THE SUBSTANTIALLY CONFORMS TO THE APPROVED OR CONDITIONALLY APPROVED TENTATIVE MAP IF ANY. I FURTHER STATE THAT ALL MONUMENTS APPROVED OF THE CHARACTER AND OCCUPY THE POSITIONS INDICATED AND THAT SAID MONUMENTS ARE SUFFICIENT TO ENABLE THE SURVEY TO BE RETRACED.

Clifford M. Zimmerman
CLIFFORD M. ZIMMERMAN, L.S. 4707
 EXPIRATION DATE: SEPTEMBER 30, 2021

Prepared by:
Clifford M. Zimmerman
 Licensed Land Surveyor, L.S. 4707
 33200 Forest Lane, Fort Bragg, Ca. 95437
 Phone: 707-489-1194

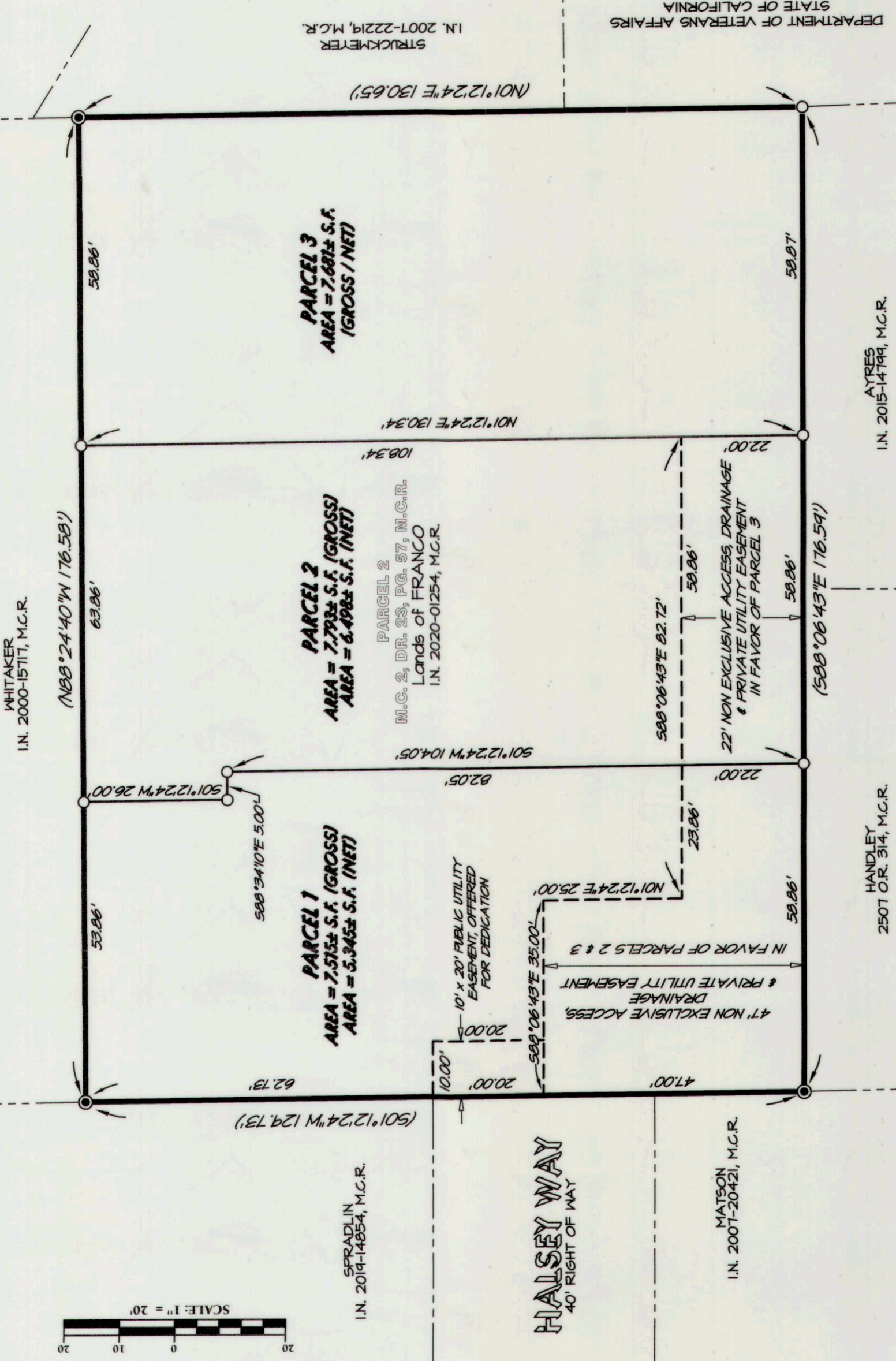

TRUSTEES STATEMENT
Recon ID Services Inc., TRUSTEE UNDER DEED OF TRUST RECORDED 1-30-2020 AS INSTRUMENT NUMBER 2020-09278 OFFICIAL RECORDS OF MENDOCINO COUNTY AGAINST THE LAND HEREIN SHOWN, HEREBY CONSENTS TO THE MAKING AND FILING OF THIS MAP.
 DATED 4-22-2021

Stephen F. Johnson
Stephen F. Johnson, President

ACKNOWLEDGMENT
 A NOTARY PUBLIC OR OTHER OFFICER COMPLETING THIS CERTIFICATE VERIFIES ONLY THE IDENTITY OF THE INDIVIDUAL WHO SIGNED THE DOCUMENT TO WHICH THIS CERTIFICATE IS ATTACHED, AND NOT THE TRUTHFULNESS ACCURACY OR VALIDITY OF THAT DOCUMENT.

STATE OF CALIFORNIA
 COUNTY OF MENDOCINO

ON 4-22-2021 BEFORE ME, **Deanna M. Sealey** Notary Public
 PERSONALLY APPEARED **Stephen F. Johnson** WHO PROVIDED TO ME ON THE BASIS OF SATISFACTORY EVIDENCE TO BE THE PERSON(S) WHOSE NAME(S) IS/ARE SUBSCRIBED TO THE WITHIN INSTRUMENT AND ACKNOWLEDGED TO ME THAT HE/SHE/IT/ THEY EXECUTED ON THE SAME IN HIS/HER/THEIR AUTHORIZED CAPACITIES, AND THAT BY HIS/HER/THEIR SIGNATURE(S) ON THE INSTRUMENT THE PERSON(S), OR THE ENTITY UPON BEHALF OF WHICH THE PERSON(S) ACTED, EXECUTED THE INSTRUMENT.

I CERTIFY UNDER PENALTY OF PERJURY UNDER THE LAWS OF THE STATE OF CALIFORNIA THAT THE FOREGOING PARAGRAPH IS TRUE AND CORRECT.
 WITNESS MY HAND AND OFFICIAL SEAL.

Deanna M. Sealey (SEAL)
Deanna M. Sealey
 Notary Public - California
 Mendocino County
 Commission # 2243469
 My Comm. Expires Jun 17, 2022

CITY SURVEYOR'S STATEMENT
 I HAVE EXAMINED THIS MAP THE SUBDIVISION AS SHOWN IS SUBSTANTIALLY THE SAME AS IT APPEARED ON THE TENTATIVE MAP AND ANY APPROVED ALTERATIONS THEREOF. ALL PROVISIONS OF CHAPTER 2, DIVISION 2 OF THE SUBDIVISION MAP ACT AND ANY LOCAL ORDINANCES APPLICABLE AT THE TIME OF APPROVAL OF THE TENTATIVE MAP HAVE BEEN COMPLIED WITH. I AM SATISFIED THE MAP IS TECHNICALLY CORRECT.
 DATED 4/16/2021
 CITY OF FORT BRAGG
 STATE OF CALIFORNIA

Thomas M. Herman
THOMAS M. HERMAN, PLS 48025

CITY CLERK'S STATEMENT
 I, **JUNE LEBOY**, CITY CLERK OF THE CITY OF FORT BRAGG, HEREBY STATE THAT THE CITY COUNCIL OF THE CITY OF FORT BRAGG BY MINUTE ORDER ON THE DAY OF 2021 APPROVED THIS SUBDIVISION AND ACCEPTED ON BEHALF OF THE PUBLIC, THE PUBLIC UTILITY EASEMENT AS OFFERED IN THE OWNER'S STATEMENT AND AS SHOWN HEREON.

STATE OF CALIFORNIA
 COUNTY OF MENDOCINO

APRIL, 2021
 JOB # 20-684
 CITY OF FORT BRAGG,
 MENDOCINO COUNTY
 CALIFORNIA

LEGEND

— LIMITS OF SUBDIVISION
 — BOUNDARY LINE, THIS SUBDIVISION
 - - - ADJOINERS' BOUNDARY LINE
 ○ EASEMENT CREATED THIS SUBDIVISION
 ○ FOUND SURVEY MONUMENT PER M.C. 2, DR. 23, PG. 57, M.C.R.
 ○ SET 3/4" REBAR WITH CAP STAMPED LS 4707
 ○ MENDOCINO COUNTY RECORDS
 ○ INSTRUMENT NUMBER, M.C.R.
 ○ OFFICIAL RECORDS, M.C.R.
 ○ MAP CASE
 ○ DRAWER
 ○ PAGE
 ○ MEASURED & RECORD DATA PER MAP CASE 2, DNR 23, PG 57, M.C.R.

PROOF OF OWNERSHIP STATEMENT
 I HEREBY STATE THAT THE PROOF OF OWNERSHIP REPORT MADE BY REDWOOD EMPIRE TITLE COMPANY OF MENDOCINO COUNTY THIS DAY OF 2021 CONFORMS TO THE PROVISIONS OF THE SUBDIVISION MAP ACT.
SUSAN M. RANDCHAK
 COUNTY RECORDER

BOND STATEMENT
 I, **CARMEL J. ANSELG**, CLERK OF THE BOARD OF SUPERVISORS OF THE COUNTY OF MENDOCINO, HEREBY STATE THAT THE BOND OR DEPOSIT AS REQUIRED BY THE SUBDIVISION MAP ACT, SECTION 64064, TITLE 7 OF THE GOVERNMENT CODE, DIV. 2 (COMMENCING WITH SEC. 64040) HAS BEEN FILED.
 DATED THIS DAY OF 2021
CARMEL J. ANSELG, CLERK OF THE BOARD OF SUPERVISORS

COUNTY RECORDER'S STATEMENT
 FILED THIS DAY OF 2021 AT M IN MAPS
 DRAWER PAGE
 OF CLIFFORD M. ZIMMERMAN
KATRINA BARTOLOME
 ASSESSOR COUNTY CLERK-RECORDER

NOTES:
 1. WATER SEWER AND DRAINAGE CAPACITY FEES (MUNICIPAL CODE SECTION 12.14.030) FOR EACH LOT SHALL BE PAID PRIOR TO THE ISSUANCE OF THE FIRST BUILDING PERMIT FOR SAID LOT.
 2. MAINTENANCE AGREEMENT(S) SHALL BE RECORDED CONCURRENTLY WITH THIS PARCEL MAP FOR PARCEL 1, 2 & 3 FOR THE NON EXCLUSIVE ACCESS, DRAINAGE, BIODETERIORATION FACILITIES AND PRIVATE ROAD EASEMENT, SHOWN HEREON.
 RECORDED AS INSTRUMENT NUMBER _____, M.C.R.

Parcel Map
 OF THE LANDS OF FRANCO
Minor Subdivision 1-20
 BEING A SUBDIVISION OF PARCEL 2 PER PARCEL MAP, FILED IN MAP CASE 2, DRAWER 23, PAGE 57, MENDOCINO COUNTY RECORDS LYING WITHIN THE SOUTHWEST QUARTER OF THE NORTHEAST QUARTER OF THE NORTHEAST QUARTER OF SECTION 7 TOWNSHIP 18 NORTH, RANGE 17 WEST, MOUNT DIABLO BASE AND MERIDIAN

APRIL, 2021
 JOB # 20-684
 CITY OF FORT BRAGG,
 MENDOCINO COUNTY
 CALIFORNIA

MAPS
 DRAWER _____
 PAGE _____

James A. Jackson
JACKSON LAW OFFICES
245 E. Laurel Street
Fort Bragg, CA 95437

Space Above This Line For Recorder's Use

EASEMENT AND MAINTENANCE AGREEMENT
DIV 1-20

This Agreement is prepared in anticipation of a minor subdivision as depicted in the attached Parcel Map DIV 1-20 (Exhibit A). The subject property is located at 130 Halsey Way, Fort Bragg, CA 95437 and is owned by Carlos F. Franco and Heather A. Franco. The minor subdivision shall result in the creation of three (3) parcels. The purpose of this agreement is to create mutual easements for access, drainage and utilities, and to provide for the maintenance of shared facilities along with the maintenance of storm water bio-retention facilities located on the respective parcels. The owners of the real property presently identified as 130 Halsey Way, in return for valuable consideration which is hereby acknowledged, hereby grant easements over Parcels 1 and 2 for the benefit of Parcels 2 and 3 as follows:

1. An easement for the use, operation and maintenance of all standard utilities serving the subdivided parcels including but not limited to water, sewer, cable and electrical service. The area of this easement is as depicted on the Parcel Map attached hereto as Exhibit A.

2. An easement for access over the easement area over Parcel 1 for the benefit of Parcel 2 and over Parcels 1 and 2 for the benefit of Parcel 3.

3. The maintenance of the stormwater bio-retention facilities depicted on the attached Exhibit B shall be the responsibility of the respective owners of Parcels 1, 2 and 3. The respective owners of these parcels shall be required to make all efforts described in Exhibit B to maintain the stormwater bio-retention facilities during their ownership of the parcels.

4. The foregoing easements are appurtenant their respective parcels and shall run with the land. The owners of Parcels 1, 2 and 3 shall be jointly responsible for the maintenance for the jointly used facilities (including but not limited to the shared driveway and utilities) and shall each be responsible for one-third of the cost of all reasonable maintenance expenses pertaining to the jointly used facilities. The individual owners of the respective parcels shall be solely responsible for the reasonable maintenance of the stormwater bio-retention facilities on their respective Parcels.

5. This Agreement contains the entire agreement relating to the foregoing easements.

6. This Agreement and all of its provisions shall be binding on and shall inure to the benefit of the heirs, assigns, executors, administrators, and successors of the parties.

7. This Agreement is entered into and shall be construed and interpreted in accordance

with the laws of the State of California. In the event of any dispute between the parties to this Agreement regarding the parties' rights and responsibilities under the Agreement, the parties agree to submit such dispute to mediation prior to commencing legal action. In the event it becomes necessary for any party to file legal action to enforce the terms of this Agreement, the prevailing party shall be entitled to an award of attorney's fees and costs arising from such litigation in addition to whatever further relief may be awarded by the court. Venue for any such legal action shall be Mendocino County, California.

Executed at Fort Bragg, California on the date set forth herein.

GRANTOR/GRANTEE

Date: April 20, 2021

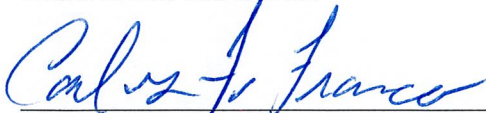

Carlos F. Franco

Date: April 20, 2021



Heather A. Franco

ACKNOWLEDGMENT

A notary public or other officer completing this certificate verifies only the identity of the individual who signed the document to which this certificate is attached, and not the truthfulness, accuracy, or validity of that document.

State of California)
County of Mendocino)

On APR. 20, 2021, before me, C. SOUTHERS, a Notary Public in and for said State, personally appeared Carlos F. Franco who proved to me on the basis of satisfactory evidence to be the persons whose name(s) is/are subscribed to the within instrument and acknowledged to me that he/she/they executed the same in his/her/their authorized capacity(ies), and that by his/her/their signature(s) on the instrument the person, or the entity upon behalf of which the person(s) acted, executed the instrument.

I certify under PENALTY OF PERJURY under the laws of the State of California that the foregoing paragraph is true and correct.

WITNESS my hand and official seal.

C. Souther
NOTARY PUBLIC in and for the State of California

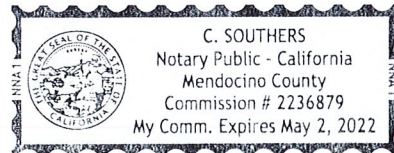

(Seal)

ACKNOWLEDGMENT

A notary public or other officer completing this certificate verifies only the identity of the individual who signed the document to which this certificate is attached, and not the truthfulness, accuracy, or validity of that document.

State of California)
County of Mendocino)

On APR. 20, 2021, before me, C. SOUTHERS, a Notary Public in and for said State, personally appeared Heather A. Franco who proved to me on the basis of satisfactory evidence to be the persons whose name(s) is/are subscribed to the within instrument and acknowledged to me that he/she/they executed the same in his/her/their authorized capacity(ies), and that by his/her/their signature(s) on the instrument the person, or the entity upon behalf of which the person(s) acted, executed the instrument.

I certify under PENALTY OF PERJURY under the laws of the State of California that the foregoing paragraph is true and correct.

WITNESS my hand and official seal.

C. SOUTHERS
NOTARY PUBLIC in and for the State of California

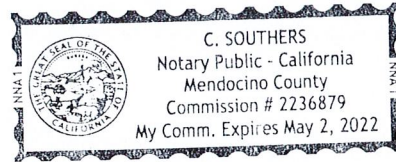

(Seal)

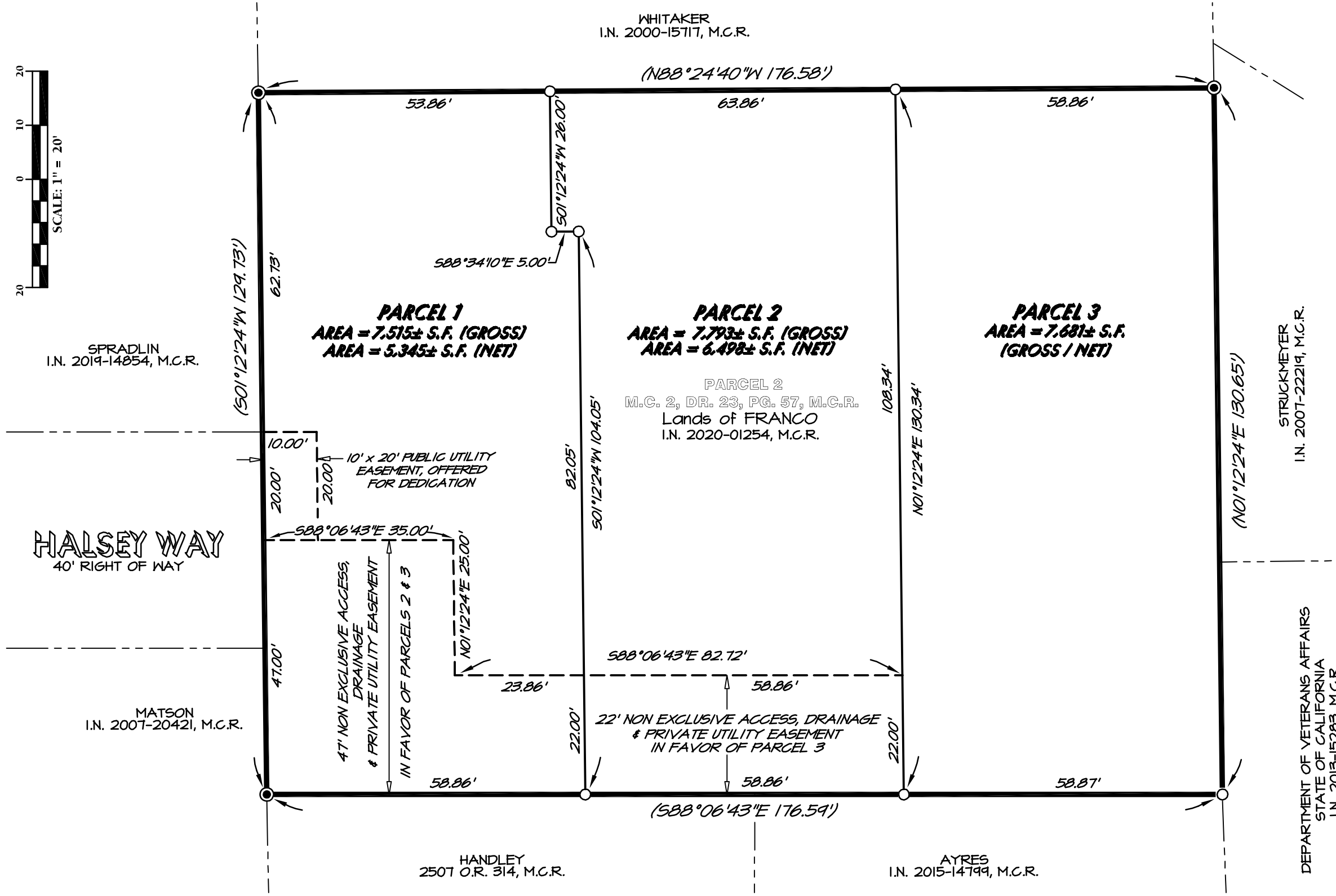
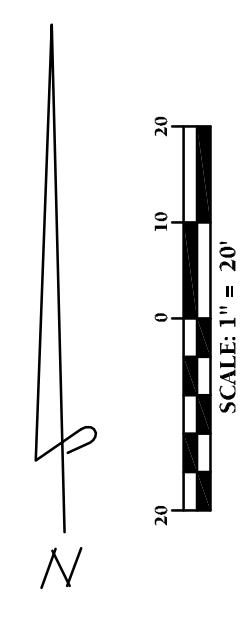
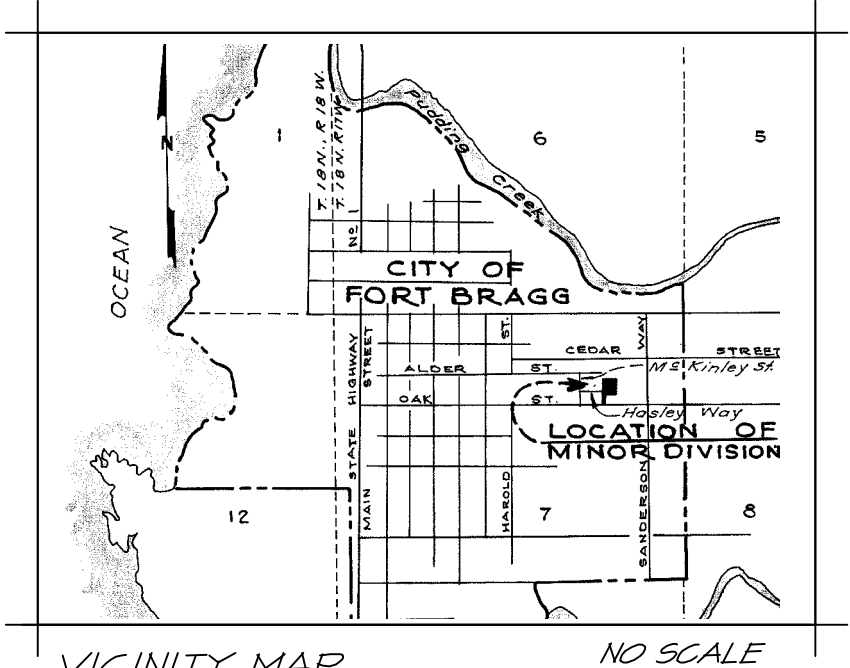

LEGEND

- LIMITS OF SUBDIVISION
- BOUNDARY LINE, THIS SUBDIVISION
- - - ADJOINERS' BOUNDARY LINE
- - - EASEMENT CREATED THIS SUBDIVISION
- ⊙ FOUND SURVEY MONUMENT PER M.C. 2, DR. 23, PG. 57, M.C.R.
- SET 3/4" REBAR WITH CAP STAMPED LS 4707
- M.C.R. MENDOCINO COUNTY RECORDS
- I.N. INSTRUMENT NUMBER, M.C.R.
- O.R. OFFICIAL RECORDS, M.C.R.
- M.C. MAP CASE
- DNR. DRAWER
- PG. PAGE
- () MEASURED & RECORD DATA PER MAP CASE 2, DNR. 23, PG 57, M.C.R.

OWNER'S STATEMENT

WE, THE UNDERSIGNED, BEING ALL PARTIES HAVING ANY RECORD TITLE INTEREST IN THE LAND WITHIN THIS DIVISION, HEREBY CONSENT TO THE PREPARATION AND RECORDATION OF THIS MAP AND DO HEREBY DEDICATE FOR PUBLIC USE THE FOLLOWING:

- 1) A PUBLIC UTILITY EASEMENT AS SHOWN HEREON.

CARLOS F. FRANCO

HEATHER A. FRANCO

ACKNOWLEDGMENT

A NOTARY PUBLIC OR OTHER OFFICER COMPLETING THIS CERTIFICATE VERIFIES ONLY THE IDENTITY OF THE INDIVIDUAL WHO SIGNED THE DOCUMENT TO WHICH THIS CERTIFICATE IS ATTACHED, AND NOT THE TRUTHFULNESS ACCURACY OR VALIDITY OF THAT DOCUMENT.

STATE OF CALIFORNIA
COUNTY OF _____

ON _____ BEFORE ME,

PERSONALLY APPEARED _____ WHO PROVED TO ME ON THE BASIS OF SATISFACTORY EVIDENCE TO BE THE PERSON(S) WHOSE NAME(S) IS/ARE SUBSCRIBED TO THE WITHIN INSTRUMENT AND ACKNOWLEDGED TO ME THAT HE/SHE/THEY EXECUTED THE SAME IN HIS/HER/their AUTHORIZED CAPACITY(IES), AND THAT BY HIS/HER/their SIGNATURE(S) ON THE INSTRUMENT THE PERSON(S), OR THE ENTITY UPON BEHALF OF WHICH THE PERSON(S) ACTED, EXECUTED THE INSTRUMENT.

I CERTIFY UNDER PENALTY OF PERJURY UNDER THE LAWS OF THE STATE OF CALIFORNIA THAT THE FOREGOING PARAGRAPH IS TRUE AND CORRECT.

WITNESS MY HAND AND OFFICIAL SEAL.

SIGNATURE _____ (SEAL)

SURVEYOR'S STATEMENT

THIS MAP WAS PREPARED BY ME OR UNDER MY DIRECTION AND IS BASED UPON A FIELD SURVEY IN CONFORMANCE WITH THE REQUIREMENTS OF THE SUBDIVISION MAP ACT AND LOCAL ORDINANCE AT THE REQUEST OF CARLOS F. FRANCO IN FEBRUARY, 2020. I, HEREBY STATE THAT THIS PARCEL MAP SUBSTANTIALLY CONFORMS TO THE APPROVED OR CONDITIONALLY APPROVED TENTATIVE MAP, IF ANY. I FURTHER STATE THAT ALL MONUMENTS ARE OF THE CHARACTER AND OCCUPY THE POSITIONS INDICATED AND THAT SAID MONUMENTS ARE SUFFICIENT TO ENABLE THE SURVEY TO BE RETRACED.

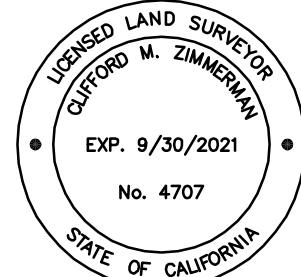

CLIFFORD M. ZIMMERMAN, L.S. 4707
EXPIRATION DATE: SEPTEMBER 30, 2021

Prepared by:
Clifford M. Zimmerman

Licensed Land Surveyor, L.S. 4707
32200 Forest Lane, Fort Bragg, Ca. 95437
Phone: 707-489-1194

CITY SURVEYOR'S STATEMENT

I HAVE EXAMINED THIS MAP, THE SUBDIVISION AS SHOWN IS SUBSTANTIALLY THE SAME AS IT APPEARED ON THE TENTATIVE MAP AND ANY APPROVED ALTERATIONS THEREOF; ALL PROVISIONS OF CHAPTER 2, DIVISION 2, OF THE SUBDIVISION MAP ACT AND ANY LOCAL ORDINANCES APPLICABLE AT THE TIME OF APPROVAL OF THE TENTATIVE MAP HAVE BEEN COMPLIED WITH; I AM SATISFIED THE MAP IS TECHNICALLY CORRECT.

DATED _____ 202__
CITY OF FORT BRAGG
STATE OF CALIFORNIA

BY: _____
MATTHEW T. HERMAN, PLS 8335

CITY CLERK'S STATEMENT

I, JUNE LEMOS, CITY CLERK OF THE CITY OF FORT BRAGG, HEREBY STATE THAT THE CITY COUNCIL OF THE CITY OF FORT BRAGG BY MINUTE ORDER

ON THE _____ DAY OF _____ 202__ APPROVED THIS SUBDIVISION AND ACCEPTED ON BEHALF OF THE PUBLIC, THE PUBLIC UTILITY EASEMENT AS OFFERED IN THE OWNER'S STATEMENT AND AS SHOWN HEREON.

_____, CITY CLERK
CITY OF FORT BRAGG

TRUSTEES STATEMENT

_____, TRUSTEE UNDER DEED OF TRUST RECORDED _____ AS INSTRUMENT NUMBER _____ OFFICIAL RECORDS OF MENDOCINO COUNTY AGAINST THE LAND HEREIN SHOWN, HEREBY CONSENTS TO THE MAKING AND FILING OF THIS MAP.

Date _____
BY: _____

ACKNOWLEDGMENT

A NOTARY PUBLIC OR OTHER OFFICER COMPLETING THIS CERTIFICATE VERIFIES ONLY THE IDENTITY OF THE INDIVIDUAL WHO SIGNED THE DOCUMENT TO WHICH THIS CERTIFICATE IS ATTACHED, AND NOT THE TRUTHFULNESS ACCURACY OR VALIDITY OF THAT DOCUMENT.

STATE OF CALIFORNIA
COUNTY OF _____

ON _____ BEFORE ME,

PERSONALLY APPEARED _____ WHO PROVED TO ME ON THE BASIS OF SATISFACTORY EVIDENCE TO BE THE PERSON(S) WHOSE NAME(S) IS/ARE SUBSCRIBED TO THE WITHIN INSTRUMENT AND ACKNOWLEDGED TO ME THAT HE/SHE/THEY EXECUTED THE SAME IN HIS/HER/their AUTHORIZED CAPACITY(IES), AND THAT BY HIS/HER/their SIGNATURE(S) ON THE INSTRUMENT THE PERSON(S), OR THE ENTITY UPON BEHALF OF WHICH THE PERSON(S) ACTED, EXECUTED THE INSTRUMENT.

I CERTIFY UNDER PENALTY OF PERJURY UNDER THE LAWS OF THE STATE OF CALIFORNIA THAT THE FOREGOING PARAGRAPH IS TRUE AND CORRECT.

WITNESS MY HAND AND OFFICIAL SEAL.

SIGNATURE _____ (SEAL)

PROOF OF OWNERSHIP STATEMENT

I HEREBY STATE THAT THE PROOF OF OWNERSHIP REPORT MADE BY REDWOOD EMPIRE TITLE COMPANY OF MENDOCINO COUNTY THIS

_____ DAY OF _____ 202__ CONFORMS TO THE PROVISIONS OF THE SUBDIVISION MAP ACT.

SUSAN M. RANOGHAK
COUNTY RECORDER

BY _____, DEPUTY

BOND STATEMENT

I, CARMEL J. ANSELO, CLERK OF THE BOARD OF SUPERVISORS OF THE COUNTY OF MENDOCINO, HEREBY STATE THAT THE BOND OR DEPOSIT AS REQUIRED BY THE "SUBDIVISION MAP ACT", SECTION 66464, TITLE 7 OF THE GOVERNMENT CODE, DIV. 2 (COMMENCING WITH SEC. 66410) HAS BEEN FILED.

DATED THIS _____ DAY OF _____ 20__
CARMEL J. ANSELO, CLERK OF THE BOARD OF SUPERVISORS

BY _____, DEPUTY

COUNTY RECORDER'S STATEMENT

FILED THIS _____ DAY OF _____ 202__ AT _____ M IN MAPS,

DRAWER _____ PAGE _____, M.C.R. AT THE REQUEST OF CLIFFORD M. ZIMMERMAN
KATRINA BARTOLOMIE
ASSESSOR, COUNTY CLERK-RECORDER

BY _____, DEPUTY FEE \$ _____

NOTES:

1. WATER, SEWER AND DRAINAGE CAPACITY FEES (MUNICIPAL CODE SECTION 12.14.030) FOR EACH LOT SHALL BE PAID PRIOR TO THE ISSUANCE OF THE FIRST BUILDING PERMIT FOR SAID LOT.
 2. MAINTENANCE AGREEMENT(S) SHALL BE RECORDED CONCURRENTLY WITH THIS PARCEL MAP FOR PARCEL 1, 2 & 3 FOR THE NON EXCLUSIVE ACCESS, DRAINAGE, BIORETENTION FACILITIES AND PRIVATE ROAD EASEMENT, SHOWN HEREON.
- RECORDED AS INSTRUMENT NUMBER _____, M.C.R.

SHEET 1 OF 1

Parcel Map

OF THE LANDS OF FRANCO
Minor Subdivision 1-20

BEING A SUBDIVISION OF PARCEL 2 PER PARCEL MAP, FILED IN MAP CASE 2, DRAWER 23, PAGE 57, MENDOCINO COUNTY RECORDS

LYING WITHIN THE SOUTHWEST QUARTER OF THE NORTHEAST QUARTER OF THE NORTHEAST QUARTER OF SECTION 7 TOWNSHIP 18 NORTH, RANGE 17 WEST MOUNT DIABLO BASE AND MERIDIAN

APRIL, 2021
JOB # 20-684
CITY OF FORT BRAGG,
MENDOCINO COUNTY
CALIFORNIA

MAPS
DRAWER _____
PAGE _____

Exhibit A

Exhibit B

Bioretention Area Monitoring & Maintenance Plan

Halsey Way Subdivision
Fort Bragg, California

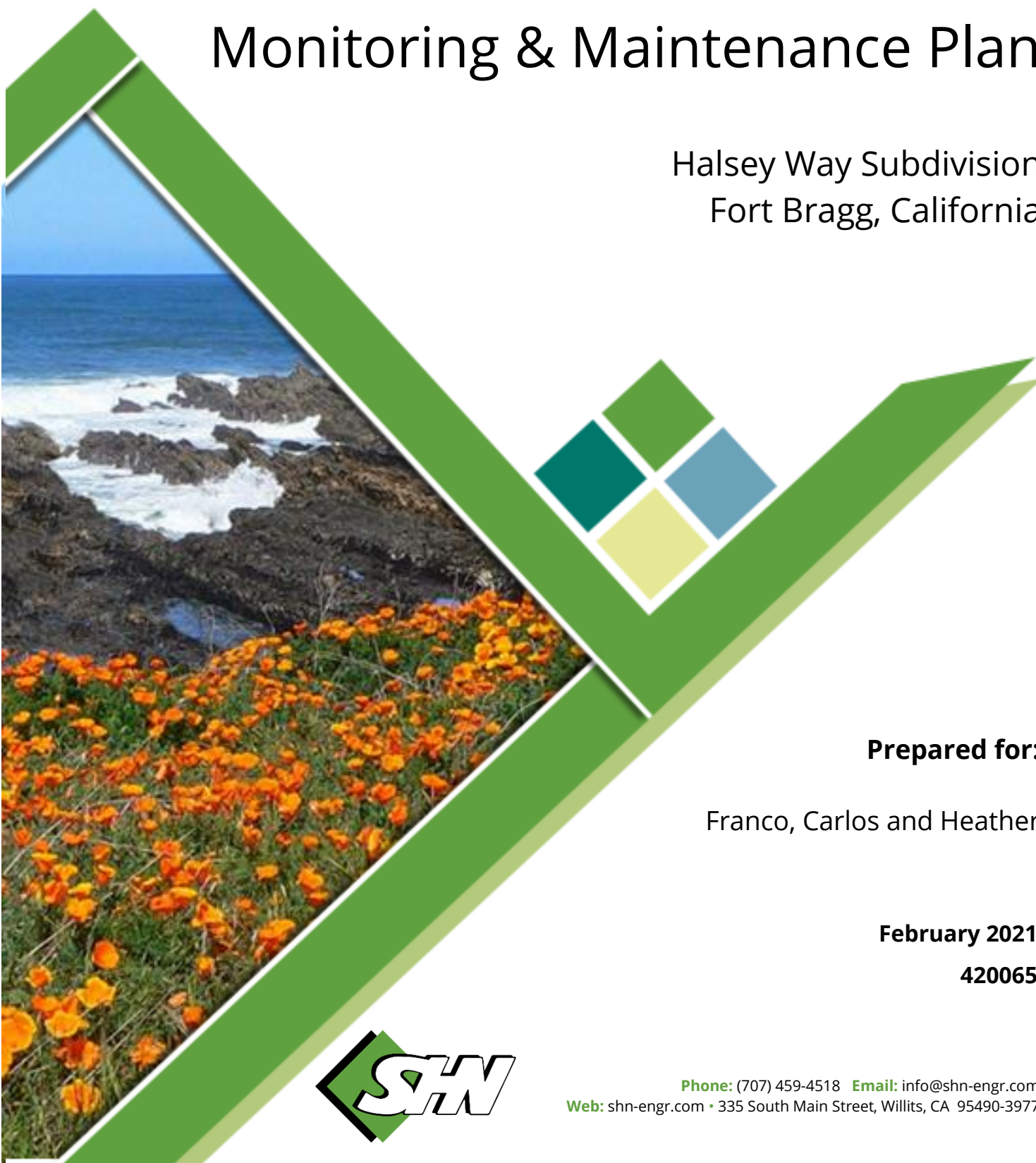

Prepared for:

Franco, Carlos and Heather

February 2021

420065



Phone: (707) 459-4518 **Email:** info@shn-engr.com
Web: shn-engr.com • 335 South Main Street, Willits, CA 95490-3977

Introduction

Maintenance of the bioretention area for the Halsey Way Subdivision is the responsibility of the property owner/manager. This maintenance plan was developed to assure proper maintenance procedures are followed and documented. After the first year of operation, the plan should be reviewed and, if necessary, revised to reflect the actual results of that first period of service. If ownership/management of the property is transferred, this maintenance plan must be transferred as well.

Regular and proper maintenance, including basic good housekeeping practices, ensure that each bioretention area will serve as an effective storm water management system for the entirety of its useful life.

Routine Maintenance Activities

The principal maintenance objective is to prevent sediment buildup and clogging, which reduce pollutant removal efficiency and may lead to bioretention area failure. Routine maintenance activities, and the frequency at which they will be conducted, are shown in Table 1.

Table 1. Routine Maintenance Activities for Bioretention Areas

No.	Maintenance Task	Frequency of Task
1	Remove obstructions, weeds, debris and trash from bioretention area and its inlets and outlets; and dispose of properly.	Monthly, or as needed after storm events
2	Inspect bioretention area for standing water. If standing water does not drain within 5 days, check if drains are clogged and consider replacement of surface biotreatment soil with the approved soil mix and replant.	Monthly, or as needed after storm events
3	Inspect inlets for channels, soil exposure, or other evidence of erosion. Clear obstructions and remove sediment.	Monthly, or as needed after storm events
4	Prune and weed the bioretention area as needed. Remove and replace all dead and diseased plants.	Twice annually
5	Check that mulch is at appropriate depth (2 - 3 inches per soil specifications) and replenish as necessary before wet season begins. It is recommended that 2" - 3" of arbor mulch be reapplied every year.	Annually, before the wet season begins
6	Inspect bioretention area using the attached inspection checklist.	Monthly, or after large storm events



Prohibitions

The use of landscaping chemicals (i.e., pesticides, herbicides, and fertilizers) in maintenance of the bio-retention basin shall be minimized to the extent feasible, to minimize the discharge of pollutants to waterways (see Appendix 1, Landscape Plan).

Only native plants shall be planted within the bioretention basin. All proposed plantings shall be obtained from local genetic stocks within Mendocino County unless documentation of such vegetation is unavailable. In such cases, native vegetation obtained from genetic stock outside of the local area may be used.

No plant species listed as problematic and/or invasive by the California Native Plant Society, the California Invasive Plant Council, or as may be identified from time to time by the State of California shall be employed or allowed to naturalize or persist within the bioretention basin.

No plant species listed as a “noxious weed” by the State of California or the U.S. Federal Government shall be planted or allowed to naturalize or persist within the bioretention basin.

Documentation

A maintenance log shall be maintained by the property owners to document all inspection observations and maintenance activities related to the bioretention area (see Appendix 2, Sample Maintenance Checklist). The maintenance log shall be available for inspection upon request by the City of Fort Bragg.



Landscape Plan

1

SUMMARY OF DRAINAGE MANAGEMENT AREAS

AREA	DESCRIPTION	SURFACE	SIZE (SF)	IMPERVIOUS AREA	BIO-SWALE AREA	BIO-RETENTION AREA	PERMEABLE SURFACE
①	LOT 1 HOME	COMPOSITION ROOF	1,550	1,550	-	67	-
②	LOT 2 HOME	COMPOSITION ROOF	2,250	2,250	-	85	-
③	LOT 3 HOME	COMPOSITION ROOF	2,250	2,250	-	90	-
④	AC DRIVEWAY	PERMEABLE AC	5,940	-	-	-	5,940

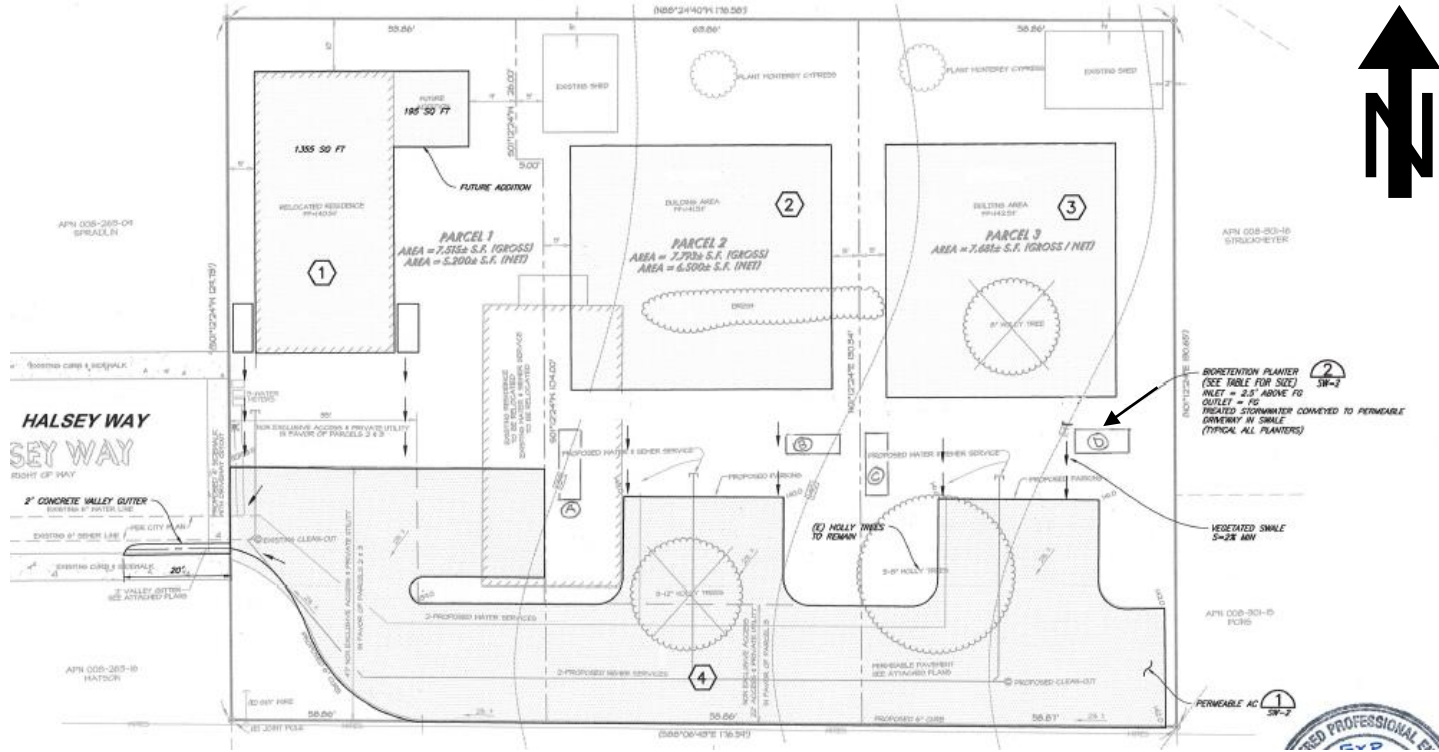

Not to Scale

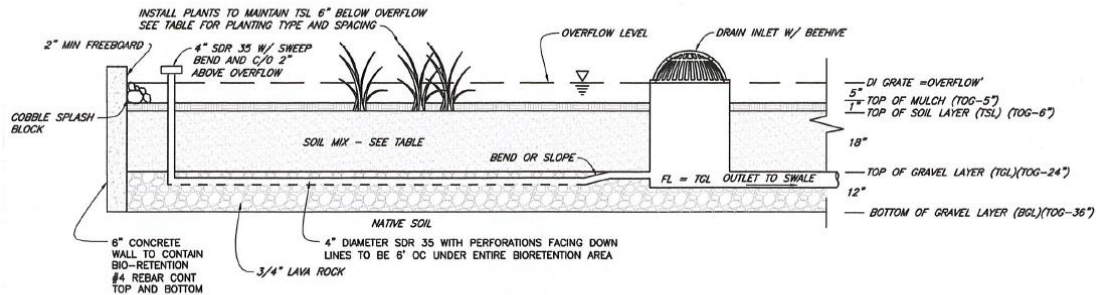

DETAIL 2
NTS SW-1
(BIO-RETENTION FACILITY)

PLANTING INFORMATION				
AREA	PLANT DESCRIPTION	SPACING	SOIL	IRRIGATION
	JUNCUS PATENS "ELK BLUE" WIRE GRASS, BLUE RUSH	EVENLY SPACED EVERY 3'	SOIL MIX PER TABLE	WATER BY HAND TWICE WEEKLY DURING DRY MONTHS FOR FIRST YEAR UNTIL ESTABLISHED

SOIL SPECIFICATIONS		
PARAMETER	RANGE	REPORTED AS (UNITS)
ORGANIC MATTER CONTENT	35-75	%, DRY WEIGHT BASIS
CARBON TO NITROGEN RATIO	15:1 TO 25:1	RATIO
MATURITY (SEED EMERGENCE AND SEEDING VIGOR)	>80	AVERAGE % OF CONTROL
STABILITY (CO ₂ EVOLUTION RATE)	<8	mg CO ₂ -C/g UNIT OM/DAY
SOLUBLE SALTS (SALINITY)	<6.0	mmhos/cm
PH	6.5-8.0 MAY VARY W/ PLANT SPECIES	UNITS
HEAVY METALS CONTENT	PASS	PASS/FAIL US EPA CLASS A STD 40 CFR § 503.13 TABLES 1 & 3
PATHOGENS		
FECAL COLIFORM	PASS	PASS/FAIL US EPA CLASS A STD 40 CFR § 503.32(A) LEVELS
SALMONELLA	PASS	PASS/FAIL US EPA CLASS A STD 40 CFR § 503.32(A) LEVELS
NUTRIENT CONTENT (PROVIDE ANALYSIS INCLUDING):		
TOTAL NITROGEN (N)	≥0.9	%
TOTAL BORON (B)	<80	PPM
CALCIUM (Ca)	FOR INFO ONLY	%
SODIUM (Na)	FOR INFO ONLY	%
MAGNESIUM (Mg)	FOR INFO ONLY	%
SULFUR (S)	FOR INFO ONLY	%

Sample Maintenance Checklist

2

Bioretention Area Inspection and Maintenance Checklist

Halsey Way Subdivision, Fort Bragg, California

Date of Inspection: _____

Type of Inspection: Quarterly Pre-Wet Season
 After Heavy Runoff End of Wet Season
 Other: _____

Inspector(s): _____

Defect	Conditions When Maintenance Is Needed	Maintenance Needed? (Y/N)	Comments (Describe maintenance completed and if needed maintenance was not conducted, note when it will be done)	Results Expected When Maintenance Is Performed
1. Standing Water	Water stands in the bioretention area between storms and does not drain within 5 days after rainfall.			There should be no areas of standing water once storm event has ceased. Any of the following may apply: sediment or trash blockages removed, improved grade from head to foot of bioretention area, or added underdrains.
2. Trash and Debris Accumulation	Trash and debris accumulated in the bioretention area, inlet, or outlet.			Trash and debris removed from bioretention area and disposed of properly.
3. Sediment	Evidence of sedimentation in bioretention area.			Material removed so that there is no clogging or blockage. Material is disposed of properly.
4. Erosion	Channels have formed around inlets, there are areas of bare soil, and/or other evidence of erosion.			Obstructions and sediment removed so that water flows freely and disperses over a wide area. Obstructions and sediment are disposed of properly.
5. Vegetation	Vegetation is dead, diseased and/or overgrown.			Vegetation is healthy and attractive in appearance.
6. Mulch	Mulch is missing or patchy in appearance. Areas of bare earth are exposed, or mulch layer is less than 2 inches in depth.			All bare earth is covered, except mulch is kept 6 inches away from trunks of trees and shrubs. Mulch is even in appearance, at a depth of 2 – 3 inches.
7. Miscellaneous	Any condition not covered above that needs attention in order for the bioretention area to function as designed.			Meets the design specifications.

Eureka, CA | Arcata, CA | Redding, CA | Willits, CA | Fort Bragg, CA | Coos Bay, OR | Klamath Falls, OR





City of Fort Bragg

416 N Franklin Street
Fort Bragg, CA 95437
Phone: (707) 961-2823
Fax: (707) 961-2802

Text File

File Number: 21-183

Agenda Date: 5/10/2021

Version: 1

Status: Consent Agenda

In Control: City Council

File Type: Resolution

Agenda Number: 5C.

Adopt City Council Resolution Authorizing the City Manager to Execute the Acceptance of an Offer of a 15-foot wide Public Right of Way dedication for South Sanderson Way from Robert L. Habekoss and Rosemary E. Habekoss

The existing lands of Habekoss extend 15 feet westerly into the normal Right of Way for South Sanderson Way. Acceptance of this dedication will bring the easterly line of South Sanderson Way in alignment with the neighboring parcels and allow Public access to existing and future City facilities located within South Sanderson Way.

RESOLUTION NO. ____-2021

RESOLUTION OF THE FORT BRAGG CITY COUNCIL AUTHORIZING THE CITY MANAGER TO EXECUTE THE ACCEPTANCE OF OFFER OF A 15-FOOT-WIDE PUBLIC RIGHT OF WAY DEDICATION FOR SOUTH SANDERSON WAY FROM ROBERT L. HABEKOSS AND ROSEMARY E. HABEKOSS

WHEREAS, the existing western boundary of the lands of Robert L. and Rosemary E. Habekoss currently extends into the normal Right of Way of South Sanderson Way; and

WHEREAS, a portion of said roadway and public utilities lies within said lands of Habekoss; and

WHEREAS, the City is required to obtain access to portions of privately owned property where public infrastructure exists in order to maintain the roadway and utilities lying therein; and

WHEREAS, the conveyance of the Right of Way will bring the South Sanderson Way Right of Way into alignment with the neighboring parcels; and

WHEREAS, the conveyance of the Right of Way will allow City and City Contractors to access, maintain, and improve the facilities in perpetuity;

NOW, THEREFORE, BE IT RESOLVED that the City Council of the City of Fort Bragg does hereby:

1. Approve the conveyance of the 15-foot-wide Public Right of Way dedication at APN 018-281-31.
2. Authorize the City Manager to execute a Certificate of Acceptance for the dedication and direct the City Clerk to send same to the Mendocino County Recorder's Office for recording.

The above and foregoing Resolution was introduced by Councilmember _____, seconded by Councilmember _____, and passed and adopted at a regular meeting of the City Council of the City of Fort Bragg held on the 10th day of May, 2021, by the following vote:

**AYES:
NOES:
ABSENT:
ABSTAIN:
RECUSED:**

BERNIE NORVELL
Mayor

ATTEST:

June Lemos, CMC
City Clerk



City of Fort Bragg

416 N Franklin Street
Fort Bragg, CA 95437
Phone: (707) 961-2823
Fax: (707) 961-2802

Text File

File Number: 21-208

Agenda Date: 5/10/2021

Version: 1

Status: Consent Agenda

In Control: City Council

File Type: Resolution

Agenda Number: 5D.

Adopt City Council Resolution Approving an Increase in Compensation for Seasonal/Temporary Classifications and the Police Services Transporter Classification

Approve Resolution to Authorize Increasing the Hourly Wage of the Seasonal/Temporary Classifications and the Police Services Transporter Classifications.

RESOLUTION NO. ____-2021

**RESOLUTION OF THE FORT BRAGG CITY COUNCIL
APPROVING AN INCREASE IN COMPENSATION FOR
SEASONAL/TEMPORARY CLASSIFICATIONS, THE POLICE SERVICES
TRANSPORTER CLASSIFICATION AND ADDS MAINTENANCE WORKER I –
JANITOR CLASSIFICATION**

WHEREAS, the State of California’s minimum wage for employers with twenty-six or more employees increases to \$15.00 effective January 1, 2022; and

WHEREAS, Resolution 4169-2019 increased compensation for the seasonal temporary Parking Enforcement Attendant position to \$16.00 in 2019; and

WHEREAS, Resolution 4239-2020 authorized the part-time/on-call Police Services Transporter classification hourly wage to be \$16.00; and

WHEREAS, the City of Fort Bragg is competing with other public agencies and private companies for workers in the local area to attract qualified and experienced individuals for the Office Assistant – Temporary, Police Services Transporter (Part-time/on-call), and the Seasonal Laborer, Seasonal Parking Enforcement Attendant classifications; and

WHEREAS, the City’s Public Works Department relies on seasonal workers in the summer and fall for various tasks; and

WHEREAS, the City relies on temporary workers and the Police Services Transporter (Part-Time/On-Call) classifications to assist during times the City is experiencing staffing shortages and/or unusually high work volume to carry out various aspects of City government; and

WHEREAS, the City wishes to increase the hourly wage for the Office Assistant – Temporary from \$15.00 to \$20.00, the Police Services Transporter (Part-Time/On-call) hourly wage from \$16.00 to \$18.00, the Seasonal Laborer hourly wage from \$14.00 to \$18.00, and the Seasonal Parking Enforcement hourly wage from \$16.00 to \$18.00; and

WHEREAS, the City wishes to add the Maintenance Worker I - Janitor classification to perform semi-skilled and skilled tasks to assist in the construction, repair and maintenance of buildings, parks and other public facilities and janitorial tasks; and

WHEREAS, the increased hourly wages for the above seasonal/temporary classifications and adding Maintenance Worker I – Janitor classification will assist the City in maintaining facilities and retain past and current incumbents to continue performing work in the applicable seasonal/temporary classification(s) to reduce recruitment and staff time costs required to effectively recruit the above-mentioned classifications for future City needs; and

WHEREAS, based on all the evidence presented, the City Council finds as follows:

1. The proposed salary increase of the aforementioned classifications and the addition of Maintenance Worker I – Janitor classification is consistent with the City-wide Compensation Plan.

2. The proposed hourly wage increase for the above Seasonal/Temporary and Police Services Transporter (Part-Time) classifications will provide for compliance with CA Minimum Wage Law and provide critical operational support necessary to carry out the mission and organizational goals of the City.
3. The addition of the Maintenance Worker I – Janitor classification is necessary to provide coverage to Public Works in maintaining City buildings, parks and other public facilities.

NOW, THEREFORE, BE IT RESOLVED that the City Council of the City of Fort Bragg does hereby approve the increased compensation for the Office Assistant – Temporary to \$20.00, the Police Services Transporter (Part-Time/On-call) hourly wage to \$18.00, the Seasonal Laborer hourly wage to \$18.00, the Seasonal Parking Enforcement hourly wage to \$18.00, and adds the Maintenance Worker I – Janitor classification to be effective May 10, 2021.

The above and foregoing Resolution was introduced by Councilmember _____, seconded by Councilmember _____, and passed and adopted at a regular meeting of the City Council of the City of Fort Bragg held on the 10th day of May, 2021, by the following vote:

AYES:
NOES:
ABSENT:
ABSTAIN:
RECUSED:

BERNIE NORVELL
Mayor

ATTEST:

June Lemos, CMC
City Clerk



City of Fort Bragg

416 N Franklin Street
Fort Bragg, CA 95437
Phone: (707) 961-2823
Fax: (707) 961-2802

Text File

File Number: 21-210

Agenda Date: 5/10/2021

Version: 1

Status: Consent Agenda

In Control: City Council

File Type: Resolution

Agenda Number: 5E.

Adopt City Council Resolution Confirming the Continued Existence of a Local Emergency in the City of Fort Bragg

At a special meeting on March 24, 2020, the Fort Bragg City Council ratified the City Manager's Proclamation declaring a local emergency due to COVID-19 in its Resolution No. 4242-2020.

Since that date, the Council has adopted the following resolutions reconfirming the existence of a local emergency:

Date Resolution No.

- April 6, 2020 4245-2020
- April 20, 2020 4247-2020
- May 11, 2020 4250-2020
- May 26, 2020 4253-2020
- June 8, 2020 4266-2020
- June 22, 2020 4270-2020
- July 13, 2020 4284-2020
- July 27, 2020 4289-2020
- August 10, 2020 4294-2020
- August 31, 2020 4300-2020
- September 21, 2020 4304-2020
- October 13, 2020 4317-2020
- October 26, 2020 4319-2020
- November 9, 2020 4323-2020
- November 23, 2020 4329-2020
- December 14, 2020 4333-2020
- December 22, 2020 4340-2020
- January 11, 2021 4343-2021
- January 25, 2021 4347-2021
- February 22, 2021 4358-2021
- March 8, 2021 4363-2021
- March 22, 2021 4366-2021
- April 12, 2021 4376-2021
- April 26, 2021 4381-2021

The City is required to reconfirm the existence of a local emergency every 21 days pursuant to Fort Bragg Municipal Code Section 2.24.040.

RESOLUTION NO. ____-2021

**RESOLUTION OF THE FORT BRAGG CITY COUNCIL
CONFIRMING THE CONTINUED EXISTENCE OF A LOCAL
EMERGENCY IN THE CITY OF FORT BRAGG**

WHEREAS, California Government Code section 8630 empowers the Fort Bragg City Council to proclaim the existence of a local emergency when the City is threatened or likely to be threatened by the conditions of extreme peril to the safety of persons and property that are or are likely to be beyond the control of the services, personnel, equipment, and facilities of this City; and

WHEREAS, California Government Code section 8558(c) states that a “local emergency” means the duly proclaimed existence of conditions of disaster or extreme peril to the safety of persons and property within the territorial limits of a city; and

WHEREAS, COVID-19, a novel coronavirus causing infectious disease, was first detected in China in December 2019 and has spread across the world and to the United States. Symptoms of COVID-19 include fever, cough, and shortness of breath; outcomes have ranged from mild to severe illness, and, in some cases, death. The Center for Disease Control and Prevention (CDC) has indicated the virus is a tremendous public health threat; and

WHEREAS, on March 13, 2020, the President of the United States issued a proclamation declaring the COVID-19 outbreak in the United States as a national emergency, beginning March 1, 2020; and

WHEREAS, the Governor of the State of California and the Public Health Officer of the County of Mendocino have both issued Shelter-in-Place orders to combat the spread of COVID-19; and

WHEREAS, on March 17, 2020 the City Manager, as the City’s Director of Emergency Services, issued Proclamation No. CM-2020-01 declaring a local emergency as authorized by Government Code section 8630 and Fort Bragg Municipal Code section 2.24.040(B); and

WHEREAS, at a special meeting on March 24, 2020, the City Council of the City of Fort Bragg adopted Resolution No. 4242-2020, ratifying the City Manager’s Proclamation declaring the existence of a local emergency; and

WHEREAS, at a special meeting on April 6, 2020, the City Council of the City of Fort Bragg adopted Resolution No. 4245-2020 by which it continued the local emergency; and

WHEREAS, at a special meeting on April 20, 2020, the City Council of the City of Fort Bragg adopted Resolution No. 4247-2020 by which it continued the local emergency; and

WHEREAS, at a regular meeting on May 11, 2020, the City Council of the City of Fort Bragg adopted Resolution No. 4250-2020 by which it continued the local emergency; and

WHEREAS, at a regular meeting on May 26, 2020, the City Council of the City of Fort Bragg adopted Resolution No. 4253-2020 by which it continued the local emergency; and

WHEREAS, at a regular meeting on June 8, 2020, the City Council of the City of Fort Bragg adopted Resolution No. 4266-2020 by which it continued the local emergency; and

WHEREAS, at a regular meeting on June 22, 2020, the City Council of the City of Fort Bragg adopted Resolution No. 4270-2020 by which it continued the local emergency; and

WHEREAS, at a regular meeting on July 13, 2020, the City Council of the City of Fort Bragg adopted Resolution No. 4284-2020 by which it continued the local emergency; and

WHEREAS, at a regular meeting on July 27, 2020, the City Council of the City of Fort Bragg adopted Resolution No. 4289-2020 by which it continued the local emergency; and

WHEREAS, at a regular meeting on August 10, 2020, the City Council of the City of Fort Bragg adopted Resolution No. 4294-2020 by which it continued the local emergency; and

WHEREAS, at a special meeting on August 31, 2020, the City Council of the City of Fort Bragg adopted Resolution No. 4300-2020 by which it continued the local emergency; and

WHEREAS, at a special meeting on September 21, 2020, the City Council of the City of Fort Bragg adopted Resolution 4304-2020 by which it continued the local emergency; and

WHEREAS, at a regular meeting on October 13, 2020, the City Council of the City of Fort Bragg adopted Resolution 4317-2020 by which it continued the local emergency; and

WHEREAS, at a regular meeting on October 26, 2020, the City Council of the City of Fort Bragg adopted Resolution 4319-2020 by which it continued the local emergency; and

WHEREAS, at a regular meeting on November 9, 2020, the City Council of the City of Fort Bragg adopted Resolution 4323-2020 by which it continued the local emergency; and

WHEREAS, at a regular meeting on November 23, 2020, the City Council of the City of Fort Bragg adopted Resolution 4329-2020 by which it continued the local emergency; and

WHEREAS, at a regular meeting on December 14, 2020, the City Council of the City of Fort Bragg adopted Resolution 4333-2020 by which it continued the local emergency; and

WHEREAS, at a special meeting on December 22, 2020, the City Council of the City of Fort Bragg adopted Resolution 4340-2020 by which it continued the local emergency; and

WHEREAS, at a regular meeting on January 11, 2021, the City Council of the City of Fort Bragg adopted Resolution 4343-2021 by which it continued the local emergency; and

WHEREAS, at a regular meeting on January 25, 2021, the City Council of the City of Fort Bragg adopted Resolution 4347-2021 by which it continued the local emergency; and

WHEREAS, at a regular meeting on February 8, 2021, the City Council of the City of Fort Bragg adopted Resolution 4351-2021 by which it continued the local emergency; and

WHEREAS, at a regular meeting on February 22, 2021, the City Council of the City of Fort Bragg adopted Resolution 4358-2021 by which it continued the local emergency; and

WHEREAS, at a regular meeting on March 8, 2021, the City Council of the City of Fort Bragg adopted Resolution 4363-2021 by which it continued the local emergency; and

WHEREAS, at a regular meeting on March 22, 2021, the City Council of the City of Fort Bragg adopted Resolution 4366-2021 by which it continued the local emergency; and

WHEREAS, at a regular meeting on April 12, 2021, the City Council of the City of Fort Bragg adopted Resolution 4376-2021 by which it continued the local emergency; and

WHEREAS, at a regular meeting on April 26, 2021, the City Council of the City of Fort Bragg adopted Resolution 4381-2021 by which it continued the local emergency;

NOW, THEREFORE, BE IT RESOLVED AND PROCLAIMED by the City Council of the City of Fort Bragg that for reasons set forth herein, said local emergency shall be deemed to continue to exist until the City Council of the City of Fort Bragg, State of California, proclaims its termination; and

BE IT FURTHER RESOLVED that the City Council of the City of Fort Bragg will review the need for continuing the local emergency at least once every 21 days until the City Council terminates the local emergency; and

BE IT FURTHER RESOLVED that this resolution confirming the continued existence of a local emergency shall be forwarded to the Director of the Governor's Office of Emergency Services and the Governor of the State of California, as well as the Mendocino County Office of Emergency Services.

The above and foregoing Resolution was introduced by Councilmember _____, seconded by Councilmember _____, and passed and adopted at a regular meeting of the City Council of the City of Fort Bragg held on the 10th day of May, 2021 by the following vote:

AYES:
NOES:
ABSENT:
ABSTAIN:
RECUSED:

BERNIE NORVELL
Mayor

ATTEST:

June Lemos, CMC
City Clerk



City of Fort Bragg

416 N Franklin Street
Fort Bragg, CA 95437
Phone: (707) 961-2823
Fax: (707) 961-2802

Text File

File Number: 21-213

Agenda Date: 5/10/2021

Version: 1

Status: Consent Agenda

In Control: City Council

File Type: Resolution

Agenda Number: 5F.

Adopt City Council Resolution Cancelling the Regularly Scheduled City Council Meeting of August 23, 2021 to Accommodate Summer Vacation Schedules

RESOLUTION NO. ____-2021

RESOLUTION OF THE FORT BRAGG CITY COUNCIL CANCELLING THE REGULARLY SCHEDULED CITY COUNCIL MEETING OF AUGUST 23, 2021 TO ACCOMMODATE SUMMER VACATION SCHEDULES

WHEREAS, Section 2.04.010 of the Fort Bragg Municipal Code states that City Council shall meet on the second and fourth Monday of every calendar month for regular Council meetings; and

WHEREAS, such regular Council meetings shall commence at the time or times as specified by resolution adopted by the City Council pursuant to Chapter 2.04; and

WHEREAS, in accordance with Section 2.04.010, the City Council may, prior to the regularly scheduled meeting, approve by resolution the cancellation of the regularly scheduled meeting;

NOW, THEREFORE, BE IT RESOLVED that the City Council of the City of Fort Bragg does hereby cancel the regular City Council meeting scheduled for August 23, 2021 to accommodate summer vacation schedules.

The above and foregoing Resolution was introduced by Councilmember _____ seconded by Councilmember _____, and passed and adopted at a regular meeting of the City Council of the City of Fort Bragg held on the 10th day of May, 2021, by the following vote:

- AYES:**
- NOES:**
- ABSENT:**
- ABSTAIN:**
- RECUSED:**

BERNIE NORVELL
Mayor

ATTEST:

June Lemos, CMC
City Clerk



City of Fort Bragg

416 N Franklin Street
Fort Bragg, CA 95437
Phone: (707) 961-2823
Fax: (707) 961-2802

Text File

File Number: 21-206

Agenda Date: 5/10/2021

Version: 1

Status: Consent Agenda

In Control: City Council

File Type: Committee Minutes

Agenda Number: 5G.

Receive and File Minutes of the March 17, 2021 Special Public Safety Committee Meeting



City of Fort Bragg

416 N Franklin Street
Fort Bragg, CA 95437
Phone: (707) 961-2823
Fax: (707) 961-2802

Meeting Minutes Public Safety Committee

Wednesday, March 17, 2021

3:00 PM

Via Video Conference

Special Meeting

MEETING CALLED TO ORDER

Meeting Chair Peters opened the meeting at 3:00 PM

ROLL CALL

Present: 2 - Bernie Norvell and Lindy Peters

- 1A.** [21-106](#) Approve Minutes of the Public Safety Committee Meeting February 17, 2021

The Committee Minutes were approved for Council review.

- 2A.** [21-107](#) Approve Minutes of the Special Public Safety Meeting February 17, 2021

A motion was made by Committee Member Norvell and seconded by Chair Peters that these Committee Minutes be approved for Council review. The motion was carried by unanimous vote.

2. PUBLIC COMMENTS ON NON-AGENDA ITEMS

Public Comments on non agenda items made by:

Jacob Patterson

Jenny Shattuck

3. CONDUCT OF BUSINESS

- 3A.** [21-102](#) Receive Report And Provide Direction On Updating Chapter 9.28 Drug Paraphernalia And On Addressing Youth Tobacco Sales In The City Of Fort Bragg

Associate Planner from the Community Development Division Heather Gurewitz presented the prepared report.

Committee members discussed the available options to update local ordinance in order regulate drug paraphernalia and youth tobacco sales in City limits.

Public Comments heard from:

Jacob Patterson

Chair Peters concluded that in order to update our outdated ordinance we will have to educate the public on the differences between in tobacco, marijuana, and methamphetamine pipes. Committee Member Norvell included that in the planned Municipal Code he would like to see a ban on flavored tobacco in order to discourage more youth from smoking. Chair Peters suggested to have more sting operations done in order to have business comply with the ordinance once a Municipal Code comes into law.

3B. [21-104](#) Receive Report And Provide Direction To Staff On Addressing The Feeding Of Wildlife On The Coast Trail

Associate Planner from the Community Development Division Heather Gurewitz presented the prepared report.

Local resident and Biologist Terra Fuller submitted a letter expressing her concerns regarding citizens feeding the wildlife on the coastal trails. California Code of Regulations 14.251.1 Harassment of Animals clearly states that if any game, nongame bird, or mammal or furbearing mammal is disrupted from their normal behavior pattern by breeding, feeding or sheltering these actions are defined as harassment.

Associate Planner Heather Gurewitz explained the two options in order to fix the issue at hand. First and foremost a local ordinance should be in place and posted along the trails to inform the public. Secondly, a public education campaign would be beneficial in order to educate the public of the risks from feeding the wildlife. She demonstrated how the City of Davis has an exceptional example of both an ordinance and a public education campaign.

Public Comments made by:

David Jensen
Cate Hawthorne
Terra Fuller
Tim Bray

Chair Peters recommended that he would like to implement both an ordinance and a public education campaign to reach more of the public. Committee Member Norvell agreed with Chair Peters in putting both options into effect. They will plan on adding this topic to a City Council Meeting to discuss and vote with the other Council Members.

3C. [21-108](#) Receive Report From Staff On Trespassing Letter Program

Community Service Officer Katelynn Holaway presented the prepared report.

There are two separate trespassing letters available to the public which assist the Fort Bragg Police Department to enforce no trespassing on properties. The first letter is a general trespass letter which allows an officer to advise individuals of trespassing and making arrest on behalf of the property or business owner. The second trespass letter is for a specific named individual who is prohibited from being on a property. In order for an arrest to be

made one of the two letters should be in effect and filed with the Fort Bragg Police Department prior to the incident. In order to obtain these letter the public can download them from City's website under the Police Department link, request a copy at the front office at the Police Department and or ask an officer out on patrol for a copy. Both letters are only active for 1 year and members will be contacted within 30 days of their letter expiring to notify them and offer them a new letter.

4. MATTERS FROM COMMITTEE / STAFF

4A. [21-109](#) Receive Oral Update From Staff on Departmental Activities

Capitan O'Neal mentioned that the Police Department is planning on purchasing new vehicles in the future. In April the Department will be welcoming two new employees one Officer and one Community Services Officer.

ADJOURNMENT

Chair Peters adjourned the meeting at 4:16 PM



City of Fort Bragg

416 N Franklin Street
Fort Bragg, CA 95437
Phone: (707) 961-2823
Fax: (707) 961-2802

Text File

File Number: 21-212

Agenda Date: 5/10/2021

Version: 1

Status: Consent Agenda

In Control: City Council

File Type: Minutes

Agenda Number: 5H.

Approve Minutes of April 26, 2021



City of Fort Bragg

416 N Franklin Street
Fort Bragg, CA 95437
Phone: (707) 961-2823
Fax: (707) 961-2802

Meeting Minutes City Council

*THE FORT BRAGG CITY COUNCIL MEETS CONCURRENTLY AS
THE FORT BRAGG MUNICIPAL IMPROVEMENT DISTRICT NO. 1
AND THE FORT BRAGG REDEVELOPMENT SUCCESSOR
AGENCY*

Monday, April 26, 2021

6:00 PM

Via Video Conference

CALL TO ORDER

Mayor Norvell called the meeting to order at 6:00 PM, all Councilmembers appearing by video conference.

PLEDGE OF ALLEGIANCE

ROLL CALL

Present: 5 - Mayor Bernie Norvell, Vice Mayor Jessica Morsell-Haye, Councilmember Tess Albin-Smith, Councilmember Lindy Peters and Councilmember Marcia Rafanan

AGENDA REVIEW

1. MAYOR'S RECOGNITIONS AND ANNOUNCEMENTS

2. PUBLIC COMMENTS ON: (1) NON-AGENDA, (2) CONSENT CALENDAR & (3) CLOSED SESSION ITEMS

(1) Public comments on non-agenda items from John T. Lombardo, Xaviera Hall and Jay McMartin were read into the record by the City Clerk. John Wojtila of the Zaremba Group, Tiffany Ferris, and Annemarie Weibel made public comments via Zoom. (2) Megan Caron spoke on Item 5C via Zoom; the City Clerk read a comment into the record from Jenny Shattuck on Item 5C. (3) None.

3. STAFF COMMENTS

City Manager Miller reported that Hubs & Routes will make a presentation to the Council regarding emergency preparedness at Town Hall in the near future, open to the public in a hybrid format. The superintendent of Mendocino College will make a presentation to Council on May 10. Miller reported that some short term solutions are in place regarding the odors from the wastewater treatment facility. Other measures to help suppress the odors, including a new dryer, will be put in place before the end of the year. Governor Newsom declared a water emergency for Mendocino and Sonoma Counties last week. A utility bill assistance program will launch on May 3. More information will be forthcoming soon. Public Works Director Smith spoke about capital improvement projects, including the raw water line project, water plant overhaul, and water meter project.

4. MATTERS FROM COUNCILMEMBERS

Councilmember Rafanan asked about a report that the restrooms on the Coastal Trail were locked. Public Works Director Smith said the locks are on a timer and he would have staff make sure they are working properly. Councilmember Peters reported on a recent Public Works & Facilities Committee meeting. A special Public Safety Committee meeting will be held April 28. Vice Mayor Morsell-Haye reported on the Citizen's Commission and the higher education ad hoc committee. A cannabis workshop is set for May 3. She asked that Council discuss increasing the salary range for construction design manager to be more competitive. The Vice Mayor also suggested additional budget for the community garden and asked the Council to consider a community grant program. Councilmember Albin-Smith noted that other Councils allow individual Councilmembers to have their own project budgets.

5. CONSENT CALENDAR

Councilmember Rafanan requested that Item 5C be removed from the Consent Calendar for further discussion.

Approval of the Consent Calendar

A motion was made by Councilmember Peters, seconded by Councilmember Rafanan, to approve the Consent Calendar with the exception of Item 5C. The motion carried by the following vote:

Aye: 5 - Mayor Norvell, Vice Mayor Morsell-Haye, Councilmember Albin-Smith, Councilmember Peters and Councilmember Rafanan

5A. [21-177](#) Adopt City Council Resolution Confirming the Continued Existence of a Local Emergency in the City of Fort Bragg

This Resolution was adopted on the Consent Calendar.

Enactment No: RES 4381-2021

5B. [21-176](#) Approve Minutes of April 12, 2021

These Minutes were approved on the Consent Calendar.

ITEMS REMOVED FROM CONSENT CALENDAR

5C. [21-186](#) Adopt City Council Resolution Authorizing City Manager to Execute Contract Amendment for Marketing Services, Increasing the Amount of the Contract with Creative Thinking, Inc. DBA The Idea Cooperative by a Not To Exceed Amount of \$24,000

Councilmember Rafanan requested clarification on what Council is being asked to approve and wanted to address the public comments on this item. The City Manager explained the resolution and gave a brief history of this agenda item. Mayor Norvell noted that the funds for this contract were already approved in previous budget amendments. Councilmember Peters said that the voters of Fort Bragg approved Measure AB which allots funds from Transient Occupancy Tax to promoting Fort Bragg.

Public Comments via Zoom were made by Jacob Patterson and Mary Rose Kaczorowski.

A motion was made by Councilmember Albin-Smith, seconded by Vice Mayor

Morsell-Haye, that this Resolution be adopted. The motion carried by the following vote:

Aye: 5 - Mayor Norvell, Vice Mayor Morsell-Haye, Councilmember Albin-Smith, Councilmember Peters and Councilmember Rafanan

Enactment No: RES 4382-2021

6. DISCLOSURE OF EX PARTE COMMUNICATIONS ON AGENDA ITEMS

Mayor Norvell disclosed conversations with the applicant in Item 8A regarding the process for proceeding with the water hookup application.

7. PUBLIC HEARING

8. CONDUCT OF BUSINESS

8A. [21-170](#) Receive Report on Request to Connect Out-of-City Property to City Water System and Provide Direction to Staff on Council Policy

City Manager Miller presented the staff report on this agenda item. She requested that Council make a policy decision so the City can be consistent going forward in response to requests for water hookups from residents outside city limits.

Public Comments via Zoom were received from Pam Sotak, Nate Orsi and Jacob Patterson.

Direction: Councilmembers unanimously agreed that the City should allow a water hookup for this one applicant if they pay the appropriate fees. City Manager Miller said if this is a policy the Council would like to change, that revision should be addressed at a future meeting.

8B. [21-172](#) Receive Report and Provide Direction to Staff on How to Interpret Existing Language in the Coastal and Inland Land Use and Development Codes

City Manager Miller summarized the staff report for this item.

Public Comment via Zoom was received from Jacob Patterson, Mary Rose Kaczorowski, Gabriel Quinn Maroney, Jamie Peters, and Annemarie Weibel. A comment from Jenny Shattuck was read by the City Clerk.

Direction: After discussion, Council directed that property owners and residents within 300 feet of the subject property have a right to request a hearing on a minor use permit or appeal a decision without charge; persons outside 300 feet must pay the specified fees.

Mayor Norvell recessed the meeting at 8:21 PM; the meeting reconvened at 8:33 PM.

8C. [21-171](#) Receive Report and Consider Adoption of City Council Resolution Authorizing Participation in the California Intergovernmental Risk Authority (CIRA) Effective 7/1/2021 with Regard to the Workers' Compensation Program

City Manager Miller gave the staff report on this agenda item.

Public Comment: None.

A motion was made by Councilmember Peters, seconded by Councilmember Albin-Smith, that this Resolution be adopted. The motion carried by the following vote:

Aye: 5 - Mayor Norvell, Vice Mayor Morsell-Haye, Councilmember Albin-Smith, Councilmember Peters and Councilmember Rafanan

Enactment No: RES 4383-2021

8D. [21-187](#) Receive Report and Consider Adoption of Municipal Improvement District Resolution Approving Contract With Synagro West, LLC to Provide Transportation of Biosolids to Land Application Sites and Authorizing City Manager to Execute Contract (Amount Not to Exceed \$70,000; Account No. 710-4712-0319)

Public Works Director Smith presented the report on this item.
Public Comment via Zoom was received from Jacob Patterson.

A motion was made by Councilmember Peters, seconded by Councilmember Albin-Smith, that this ID Resolution be adopted. The motion carried by the following vote:

Aye: 5 - Mayor Norvell, Vice Mayor Morsell-Haye, Councilmember Albin-Smith, Councilmember Peters and Councilmember Rafanan

Enactment No: RES ID 443-2021

9. CLOSED SESSION

Mayor Norvell recessed the meeting at 8:45 PM. The meeting reconvened to Closed Session at 8:49 PM.

9A. [21-179](#) CONFERENCE WITH LABOR NEGOTIATORS: Pursuant to Government Code Section 54957.6: City Negotiator: Tabatha Miller, City Manager; Employee Organizations: Fort Bragg Police Association; Confidential Non-Bargaining Classifications; Exempt At-Will Executive Classifications; and Exempt Mid-Management Classifications

Mayor Norvell reconvened the meeting to Open Session at 9:17 PM and reported that no reportable action was taken on the Closed Session item.

ADJOURNMENT

Mayor Norvell adjourned the meeting at 9:17 PM.

BERNIE NORVELL, MAYOR

June Lemos, CMC, City Clerk

IMAGED (_____)



City of Fort Bragg

416 N Franklin Street
Fort Bragg, CA 95437
Phone: (707) 961-2823
Fax: (707) 961-2802

Text File

File Number: 21-218

Agenda Date: 5/10/2021

Version: 1

Status: Consent Agenda

In Control: City Council

File Type: Minutes

Agenda Number: 5I.

Approve Minutes of Special Closed Session of April 30, 2021



City of Fort Bragg

416 N Franklin Street
Fort Bragg, CA 95437
Phone: (707) 961-2823
Fax: (707) 961-2802

Meeting Minutes Special City Council

*THE FORT BRAGG CITY COUNCIL MEETS CONCURRENTLY AS
THE FORT BRAGG MUNICIPAL IMPROVEMENT DISTRICT NO. 1
AND THE FORT BRAGG REDEVELOPMENT SUCCESSOR
AGENCY*

Friday, April 30, 2021

4:30 PM

Via Video Conference

Special Closed Session

CALL TO ORDER

Mayor Norvell called the meeting to order at 4:30 PM, all Councilmembers appearing by video conference.

ROLL CALL

Present: 5 - Mayor Bernie Norvell, Vice Mayor Jessica Morsell-Haye, Councilmember Tess Albin-Smith, Councilmember Lindy Peters and Councilmember Marcia Rafanan

1. PUBLIC COMMENTS ON CLOSED SESSION ITEMS

None.

2. CLOSED SESSION

Mayor Norvell recessed the meeting at 4:32 PM. The meeting reconvened to Closed Session at 4:33 PM.

2A. [21-204](#)

CONFERENCE WITH LEGAL COUNSEL - ANTICIPATED LITIGATION: Significant exposure to litigation pursuant to Paragraph (2) of Subdivision (d) of California Government Code Section 54956.9: Three (3) Potential Cases: Claim from Makayla Hite, Breach of Confidentiality; Claim from Richard Garcia, Harassment; Claim from Jacob Patterson, Disparate Treatment

2B. [21-205](#)

CONFERENCE WITH REAL PROPERTY NEGOTIATORS FOR POSSIBLE ACQUISITION OF REAL PROPERTY, Pursuant to Government Code Section §54956.8: Real Property: APN 018-430-22-00, 90 W Redwood Ave., Fort Bragg, CA 95437; City Negotiator: Tabatha Miller, City Manager; Negotiating Party: Dave Massengill, Environmental Affairs, Georgia Pacific Corporation; Under Negotiation: Terms of Acquisition, Price

Mayor Norvell reconvened the meeting to Open Session at 5:20 PM and reported that no reportable action was taken on the Closed Session items.

ADJOURNMENT

Mayor Norvell adjourned the meeting at 5:20 PM.

BERNIE NORVELL, MAYOR

June Lemos, CMC, City Clerk

IMAGED (_____)



City of Fort Bragg

416 N Franklin Street
Fort Bragg, CA 95437
Phone: (707) 961-2823
Fax: (707) 961-2802

Text File

File Number: 21-219

Agenda Date: 5/10/2021

Version: 1

Status: Consent Agenda

In Control: City Council

File Type: Minutes

Agenda Number: 5J.

Approve Minutes of Special Meeting of May 3, 2021



City of Fort Bragg

416 N Franklin Street
Fort Bragg, CA 95437
Phone: (707) 961-2823
Fax: (707) 961-2802

Meeting Minutes Special City Council

*THE FORT BRAGG CITY COUNCIL MEETS CONCURRENTLY AS
THE FORT BRAGG MUNICIPAL IMPROVEMENT DISTRICT NO. 1
AND THE FORT BRAGG REDEVELOPMENT SUCCESSOR
AGENCY*

Monday, May 3, 2021

6:00 PM

Via Video Conference

Cannabis Ordinance

CALL TO ORDER

Mayor Norvell called the meeting to order at 6:00 PM, all Councilmembers appearing via video conference.

ROLL CALL

Present: 5 - Mayor Bernie Norvell, Vice Mayor Jessica Morsell-Haye, Councilmember Tess Albin-Smith, Councilmember Lindy Peters and Councilmember Marcia Rafanan

1. CONDUCT OF BUSINESS

- 1A. [21-198](#)** Receive Report and Recommend Edits to Ordinance to Update Municipal Code 9.30 Cannabis Businesses

Associate Planner Gurewitz presented the staff report on this agenda item.

Public Comment via Zoom was received from Jacob Patterson.

Direction: Council directed staff to revise Municipal Code Chapter 9.30 by: (1) using the State of California's language which focuses on owners and applicants, and not on employees, (2) centralizing cannabis application processing in the Community Development Department instead of the Police Department, and (3) adding definitions to Chapter 9.30.

This Staff Report was referred to staff.

- 1B. [21-201](#)** Receive Report and Provide Direction on a Cannabis Cultivation Policy

Associate Planner Gurewitz gave the staff report for this agenda item.

Public Comment via Zoom was received from Simeon, Michael Strupp and Jacob Patterson. The City Clerk read a comment from Brandy Moulton.

Mayor Norvell recessed the meeting at 6:58 PM; the meeting reconvened at 7:00 PM.

Direction: After discussion, the Council provided feedback to staff by completing the chart on Page 10 of the PowerPoint Presentation as follows:

- Outdoor Cultivation - prohibited for commercial, allowed for personal.
- Indoor Cultivation - allowed
- Mixed Light Cultivation - allowed
- Water Usage Plan - shall (requirement)
- Water Conservation Measures - shall (requirement)

- Private Water Source - should (recommendation)
- Water Reclamation - shall (required)
- LED Lighting - should (recommendation)
- Solar Panels or Sonoma Clean Power - should (recommendation)

This Staff Report was referred to staff.

1C. [21-199](#) Receive Report and Provide Direction to Staff on Where Commercial Cannabis Cultivation, as a Primary Use, Should be Allowed

Associate Planner Gurewitz gave the staff report for this item.

Public Comment via Zoom was received from Jacob Patterson, Simeon, and Michael Strupp.

Direction: Council directed that cannabis businesses may be allowed in the Light Industrial (IL) and Heavy Industrial (IH) zoning districts with an administrative permit, and in the Highway and Visitor Commercial (CH) and General Commercial (CG) zoning districts with a use permit.

This Staff Report was referred to staff.

1D. [21-202](#) Receive Report and Provide Direction to Staff on Whether to Create a Cannabis Microbusiness Category or Enhance the Accessory Use Definition in Inland Land Use and Development Code Section 18.42.057

This item was continued to a special meeting set for May 20, 2021 at 6:00 PM.

This Staff Report was continued to May 20, 2021 at 6:00 PM.

ADJOURNMENT

Mayor Norvell adjourned the meeting at 8:08 PM.

BERNIE NORVELL, MAYOR

June Lemos, CMC, City Clerk

IMAGED (_____)



City of Fort Bragg

416 N Franklin Street
Fort Bragg, CA 95437
Phone: (707) 961-2823
Fax: (707) 961-2802

Text File

File Number: 21-223

Agenda Date: 5/10/2021

Version: 1

Status: Consent Agenda

In Control: City Council

File Type: Minutes

Agenda Number: 5K.

Approve Minutes of Special Closed Session of May 4, 2021



City of Fort Bragg

416 N Franklin Street
Fort Bragg, CA 95437
Phone: (707) 961-2823
Fax: (707) 961-2802

Meeting Minutes Special City Council

*THE FORT BRAGG CITY COUNCIL MEETS CONCURRENTLY AS
THE FORT BRAGG MUNICIPAL IMPROVEMENT DISTRICT NO. 1
AND THE FORT BRAGG REDEVELOPMENT SUCCESSOR
AGENCY*

Tuesday, May 4, 2021

6:00 PM

Via Video Conference

Special Closed Session

CALL TO ORDER

Mayor Norvell called the meeting to order at 6:02 PM.

ROLL CALL

Present: 4 - Mayor Bernie Norvell, Councilmember Tess Albin-Smith, Councilmember Lindy Peters and Councilmember Marcia Rafanan
Absent: 1 - Vice Mayor Jessica Morsell-Haye

1. PUBLIC COMMENTS ON CLOSED SESSION ITEMS

None.

2. CLOSED SESSION

Mayor Norvell recessed the meeting at 6:03 PM; the meeting reconvened to Closed Session at 6:12 PM.

2A. [21-215](#)

CONFERENCE WITH REAL PROPERTY NEGOTIATORS FOR POSSIBLE ACQUISITION OF REAL PROPERTY, Pursuant to Government Code Section § 54956.8: Real Property: APN 020-550-02-00, APN 020-550-09-00 "Pudding Creek"; City Negotiators: Tabatha Miller, City Manager; Negotiating Party: Dave Massengill, Environmental Affairs, Georgia Pacific Corporation; Under Negotiation: Terms of Acquisition

Mayor Norvell reconvened the meeting to Open Session at 7:04 PM and reported that no reportable action had been taken on the Closed Session item.

ADJOURNMENT

Mayor Norvell adjourned the meeting at 7:04 PM.

BERNIE NORVELL, MAYOR

June Lemos, CMC, City Clerk

IMAGED (_____)



City of Fort Bragg

416 N Franklin Street
Fort Bragg, CA 95437
Phone: (707) 961-2823
Fax: (707) 961-2802

Text File

File Number: 21-220

Agenda Date: 5/10/2021

Version: 1

Status: Business

In Control: City Council

File Type: Ordinance

Agenda Number: 8A.

Receive Report and Consider Introducing by Title Only and Waiving the First Reading of Ordinance 966-2021 Amending Chapter 9.30 (Cannabis Businesses) of Title 9 (Public Peace, Safety and Morals) of the Fort Bragg Municipal Code



AGENCY: City of Fort Bragg
MEETING DATE: May 10, 2021
DEPARTMENT: Community Development
PRESENTED BY: Heather Gurewitz
EMAIL ADDRESS: hgurewitz@fortbragg.com

AGENDA ITEM SUMMARY

TITLE:

Receive Report and Consider Introducing by Title Only and Waiving the First Reading of Ordinance 966-2021 Amending Chapter 9.30 (Cannabis Businesses) of Title 9 (Public Peace, Safety and Morals) of the Fort Bragg Municipal Code

ISSUE:

Since the passage of the Medical Marijuana Regulation and Safety Act (MMRSA, 2015) and the Adult Use of Marijuana Act (AUMA, 2016), the State of California, through its Bureau of Cannabis Control, has been developing the laws, regulations and licensing requirements for cannabis businesses. On January 16, 2019, the California Office of Administrative Law (OAL) approved the Bureau of Cannabis Control's revised cannabis regulations.

The City of Fort Bragg adopted Ordinance 928-2017 in early 2017 regulating cannabis manufacturing uses following passage of the AUMA. Ordinance 928-2017 was applied and paid for by an applicant seeking to establish a cannabis manufacturing business in the City.

On February 12, 2018, the City Council provided direction to staff to revise the City's dispensary regulations. The City Council held numerous meetings to discuss cannabis business activities in the City of Fort Bragg since the passage of AUMA in 2016 and the adoption of the Medical Cannabis Regulation and Safety Act in 2017. Chapter 9.30 Cannabis Businesses of Title 9 (Public, Peace, Safety, and Morals) of the Fort Bragg Municipal Code (Code) was adopted on November 21, 2019, and addresses cannabis businesses in general but does not have provisions for cannabis cultivation. On October 13, 2020, the City Council directed staff to develop regulations and allow commercial cannabis cultivation within the City limits.

Additionally, through the implementation of Chapter 9.30, staff identified several sections of the Code that lacked clarity or could be revised to streamline the application process.

Staff met with the Community Development Committee on February 23, 2021 and March 23, 2021 to discuss changes to Chapter 9.30, the possible inclusion of cannabis cultivation within the City limits, and potential changes to include cultivation in the Inland Land Use and Development Code. Committee members deliberated, received public input, and provided direction to staff.

The City Council met on May 3, 2021 to discuss potential changes to Chapter 9.30 and the possibility of allowing commercial cannabis cultivation. The Council received public input, deliberated, and provided direction to staff on changes to chapter 9.30 and for the development of commercial cannabis cultivation regulations.

AGENDA ITEM NO. 8A

Staff reviewed Council direction and determined that the requirements for commercial cannabis cultivation can be included in the updates of Chapter 9.30.

ANALYSIS:

This ordinance is one of the required actions necessary to allow commercial cannabis cultivation in the City of Fort Bragg. If Council adopts the Ordinance, the City Council will still need to adopt an update to the Inland Land Use and Development Code (ILUDC) and the Coastal Land Use and Development Code (CLUDC) before it is allowable in either part of the City. The Council is scheduled to continue discussion of the land uses on May 20, 2021 for the ILUDC, after which it will be reviewed by the Planning Commission for additional recommendations before possible adoption by City Council.

If passed, the attached ordinance will make the following changes to Chapter 9.30:

Change	Effect
Move the management of Cannabis Business Permit applications from the City of Fort Bragg Police Department to Community Development Department.	The purpose of this change is to streamline the process and centralize applications for cannabis business activities with other required permissions in one department. The Police Department will still maintain authority over the public safety and criminal background elements of applications.
Change the grounds for denial based on criminal history in Section 9.30.100D to match the State of California Grounds for rejection of a cannabis license based on criminal history.	The City's code provided a stricter basis for denial of a cannabis business permit due to criminal history. The Council reviewed the existing regulation in comparison with the state and other local jurisdictions and gave staff direction to update the code to be consistent with the requirements of the State.
Make it legal for commercial cannabis to be cultivated within the City of Fort Bragg.	Currently, no section of the code addresses commercial cannabis cultivation. The additional sections of section 9.30 provide regulation and application requirements for parties interested in commercially cultivating cannabis within the City Limits.
Limit the cultivation of cannabis to indoor cultivation within a Fully Enclosed and Secure Structure (FESS).	At direction of City Council, commercial cannabis cultivation will only be allowable if it is grown in a Fully Enclosed and Secure Structure (FESS). This includes a greenhouse as long as it is not visible from the public right of way.

Change	Effect
Require all proposed commercial cannabis cultivations to be evaluated in compliance with CEQA.	All permits issued through Chapter 9.30 will be discretionary permits and therefore qualify as projects and must be evaluated in compliance with CEQA. Each project will be individually evaluated.
Require commercial cannabis cultivation applicants to submit a water usage plan and an energy usage plan.	At direction from Council, staff included requirements for both a water usage and energy usage plan that will include conservation measures.
Require all commercial cannabis cultivations to use on-site water recycling practices.	This will reduce the impacts of cultivation on the City's water and wastewater systems and was included at the direction of Council.
Require all commercial cannabis cultivations to enroll in Sonoma Clean Power or install solar panels.	At the direction of Council, staff included this requirement to minimize impacts on the energy grid and reduce the environmental impacts of cultivation.

City Council provided direction to include LED lighting, private water sources, and water as a “should” in the code. However, in his review of the ordinance, the City Attorney strongly discouraged the use of the word should, because it is not an enforceable word despite its ample use throughout various sections of the Municipal Code including the CLUDC and the ILUDC. If the Council wants to provide recommendations, they can be included in the updates to the ILUDC under “Specific Land Use Standards.”

Environmental Determination

In the initial review, the proposed ordinance was found to be exempt from CEQA in accordance with Section 26055(h) of the California Business and Professional Code, which allows local jurisdictions to adopt an ordinance, rule, or regulation that requires discretionary review and approval of permit to engage in commercial cannabis activity. This exemption becomes inoperative on July 1, 2021. If there are changes required prior to adoption, staff will redo the initial review and may be required to conduct an initial study in order to comply with CEQA.

Note: This is an exemption for the passing of this ordinance only. Any changes to the Inland Land Use and Development Code will have to be reviewed under CEQA and all cannabis cultivation projects will have to be reviewed for compliance with CEQA as noted in Section 9.30.120 and Section 9.30.140 of the proposed ordinance.

While Cannabis cultivation in the City will not be allowable until the Council passes an ordinance to address cannabis cultivation in the ILUDC, passing this ordinance moves this process forward and qualifies for the current CEQA exemption due to expire on July 1, 2021.

RECOMMENDED ACTION:

Staff recommends introduction of Ordinance 966-2021 on May 10, 2021, with adoption of the ordinance scheduled for the next regular meeting of the City Council, on May 24, 2021.

ALTERNATIVE ACTION(S):

Make changes to the proposed ordinance and/or postpone adoption and conduct a new CEQA initial study and possibly initial review before bringing it back to Council.

FISCAL IMPACT:

There is no significant fiscal impact by adopting this ordinance.

GREENHOUSE GAS EMISSIONS IMPACT:

Cannabis cultivation can be an energy intensive activity. However, the City’s proposed ordinance requires an energy conservation plan. Until changes to the ILUDC are adopted to allow cannabis cultivation, the actual impacts on GHG emissions is unknown and impossible to estimate, but will be considered on a case-by-case basis.

CONSISTENCY:

Goal/Policy/Program	Consistency
Land Use Goal LU-5: Support industrial development which is consistent with the protection, enhancement, and restoration of natural and scenic resources.	The ordinance will provide another opportunity for industrial development but provides regulation that will reduce the impact of the activity on the environment.
Public Facilities Program PF-2.2.5: Continue to encourage water conservation techniques and water conserving fixtures in all new development projects.	The ordinance requires commercial cannabis cultivations onsite water recycling and a plan for water conservation.
Sustainability Goal S-2: Encourage development that minimizes the demand for non-renewable energy and reduces Green House Gas (GHG) emissions.	The ordinance requires commercial cannabis cultivations to provide an energy plan for energy conservation measures and allows for a greenhouse meeting the definition of a FESS to encourage the use of natural light.
Policy S-3.1: Reduce Water Use: Minimize the use of potable water in new and existing development.	The ordinance requires commercial cannabis cultivations to have onsite water recycling and a plan for water conservation

The proposed ordinance does not conflict with any of the elements, goals, policies, or programs of the general plan.

IMPLEMENTATION/TIMEFRAMES:

If introduced by City Council, the ordinance will be placed on the Consent Calendar for adoption at the City Council meeting on May 24th and will take effect on June 23, 2021.

ATTACHMENTS:

1. Draft Ordinance amending Chapter 9.30 "Cannabis Businesses"

NOTIFICATION:

1. Cannabis Notify Me subscriber list

BEFORE THE CITY COUNCIL OF THE CITY OF FORT BRAGG

**AN ORDINANCE AMENDING CHAPTER
9.30 (CANNABIS BUSINESSES) OF
TITLE 9 (PUBLIC PEACE, SAFETY AND
MORALS) OF THE FORT BRAGG
MUNICIPAL CODE**

ORDINANCE NO. 966-2021

WHEREAS, the City of Fort Bragg’s (“City”) previously adopted ordinances governing cannabis businesses do not provide regulations for commercial cannabis cultivation; and

WHEREAS, in 1970, Congress enacted the Controlled Substances Act (21 U.S.C. Section 801 et seq.) which, among other things, makes it illegal to import, manufacture, distribute, possess, or use marijuana for any purpose in the United States and further provides criminal penalties for marijuana possession, cultivation and distribution; and

WHEREAS, the People of the State of California have enacted Proposition 215, the Compassionate Use Act of 1996 (codified at Health and Safety Code Section 11362.5 et seq.) (the “CUA”), which exempts qualified patients and their primary caregivers from criminal prosecution under enumerated Health and Safety Code sections for use of marijuana for medical purposes; and

WHEREAS, the California Legislature enacted Senate Bill 420 in 2003, the Medical Marijuana Program Act (codified at Health and Safety Code Section 11362.7 et seq.) (the “MMPA”), as amended, which created a state-wide identification card scheme for qualified patients and primary caregivers; and

WHEREAS, on October 11, 2015, the Governor signed into law Senate Bill 643, Assembly Bill 266, and Assembly Bill 243, collectively referred to as the Medical Cannabis Regulation and Safety Act (MCRSA) formerly known as (the Medical Marijuana Regulation and Safety Act or MMRSA), effective January 1, 2016, which established a state licensing system for medical marijuana cultivation, manufacturing, testing, delivery, and dispensing, regulating these activities with licensing requirements and regulations that are only applicable if cities and counties also permit marijuana cultivation, manufacturing, testing, dispensing, and delivery within their jurisdictions. Under the MCRSA, cities and counties may continue to regulate and/or prohibit medical marijuana cultivation, manufacturing, dispensing, and delivery, consistent with their respective police powers, in which case the new law would not allow or permit these activities within the cities and counties where such activities are not otherwise permitted; and

WHEREAS, on February 3, 2016, Assembly Bill 21 (Wood) was signed by the Governor, amending provisions of MCRSA pertaining to cultivation licenses by eliminating a March 1, 2016 deadline for local jurisdictions for the promulgation of cultivation regulations or cultivation bans, or local jurisdictions would lose the ability to regulate to the State. Assembly Bill 21 also modified language in Health & Safety Code section 11362.777(g),

which pertained to exemptions from licensing requirements for qualified patients and caregivers. The prior language, which specifically stated that local governments retained the right to prohibit cultivation without exception, was revised to state: “Exemption from the requirements of this section does not limit or prevent a city, county, or city and county from exercising its police authority under Section 7 of Article XI of the California Constitution;” and

WHEREAS, on November 8, 2016, the electorate of the State of California approved Proposition 64 (“Prop 64”) which enacted the Adult Use of Marijuana Act (“AUMA”), to be codified in California Health and Safety Code at various sections and in California Business and Professions Code at various sections. The AUMA allows adults 21 and over to use, possess, and cultivate limited amounts of marijuana, establishes a state licensing and regulatory scheme for marijuana businesses serving the recreational market; and expressly allows local jurisdictions to prohibit outdoor cultivation of marijuana for personal use, to regulate indoor cultivation of marijuana for personal use, and to prohibit all non-medical and recreational marijuana businesses from locating and operating within their jurisdictions; and

WHEREAS, on June 27, 2017, the Governor approved Senate Bill 94 which combined the regulatory schemes for MMRSA and AUMA into a single, comprehensive regulatory scheme known as the Medicinal and Adult-Use Cannabis Regulation and Safety Act (“MAUCRSA”); and

WHEREAS, notwithstanding the CUA, MMPA, MMRSA, and MAUCRSA as amended, marijuana remains a schedule I substance pursuant to California Health & Safety Code § 11054 (d) (13); and

WHEREAS, the California Supreme Court has established that neither the CUA nor the MMPA preempt local cannabis regulation in the case of *City of Riverside v. Inland Empire Patients Health and Wellness Center, Inc.*, 56 Cal.4th 729 (2013); and

WHEREAS, on February 25, 2019, the City Council of the City of Fort Bragg (“City Council”) sought to establish rules and regulations by which cannabis businesses may be permitted by considering an ordinance regulating retail, laboratory testing, manufacturing, and distribution cannabis businesses and accessory uses; and

WHEREAS, through multiple public meetings, the Public Safety Committee, Fort Bragg Police Department and City staff have received input from citizens and discussed various options for permitting cannabis businesses; and

WHEREAS, on November 21, 2019, the City Council of the City of Fort Bragg (“City Council”) adopted Ordinance 953-2019 which established rules and regulations by which cannabis businesses may be permitted; and

WHEREAS, on October 13, 2020, the City Council of the City of Fort Bragg (“City Council”) directed staff to develop regulations on commercial cannabis cultivation; and

WHEREAS, the Community Development Committee met on February 23, 2021 and March 23, 2021 to review recommended updates to the Municipal Code and Inland Land Use and Development Code to include cannabis cultivation and receive public input; and

WHEREAS, on May 3, 2021, the City Council of the City of Fort Bragg received public input and directed staff to update the rules and regulations to streamline permitting under the Community Development Department; and

WHEREAS, also on May 3, 2021, the City Council determined that specific regulations and requirements were necessary to allow the commercial cultivation of cannabis cultivation in the City of Fort Bragg; and

WHEREAS, City Council has determined that Chapter 9.30 should be amended to regulate the commercial cultivation of cannabis; and

WHEREAS, the City Council finds that the adoption of this ordinance is exempt from environmental review under the California Environmental Quality Act (CEQA) pursuant to California Business and Professions Code 26055(h). CEQA does not apply because this ordinance requires discretionary review and approval of permits, licenses, and other authorizations to engage in commercial cannabis activity.

NOW, THEREFORE, the City Council ordains as follows:

Section 1. Legislative Findings. The City Council hereby finds as follows:

1. The foregoing recitals are true and correct and are incorporated into this ordinance.
2. Amending Chapter 9.30 to the Municipal Code in the manner described will ensure that cannabis businesses are effectively regulated so that they will not be detrimental to the public interest, health, safety, convenience or welfare of the City.
3. The adoption of this ordinance is exempt from the California Environmental Quality Act (“CEQA”), pursuant to California Business and Professions Code 26055(h), CEQA does not apply because this ordinance requires discretionary review and approval of permits, licenses, and other authorizations to engage in commercial cannabis activity.

Section 2. Chapter 9.30 (“Cannabis Businesses”) of Title 9 (“Public Peace, Safety and Morals”) of the Fort Bragg Municipal Code is hereby amended to provide as follows:

Chapter 9.30 Cannabis Businesses

Section

- 9.30.010 Purpose and intent
- 9.30.020 Definitions
- 9.30.030 Limitations on use
- 9.30.040 Cannabis businesses permit

- 9.30.050 Applications
- 9.30.060 Time limit for filing application for permit
- 9.30.070 Term of permits and renewals
- 9.30.080 Fees
- 9.30.090 Investigation and action on application
- 9.30.100 Grounds for rejection of application
- 9.30.110 Appeal from Chief of Police decision to reject application
- 9.30.120 Processing of cannabis business permit
- 9.30.130 Operating requirements
- 9.30.140 Commercial cannabis cultivation requirements
- 9.30.150 Minors
- 9.30.160 Display of permit
- 9.30.170 Registration of new employees
- 9.30.180 Transfer of permits
- 9.30.190 Suspension and revocation – notice
- 9.30.200 Suspension and revocation – grounds
- 9.30.210 Suspension and revocation – appeals
- 9.30.220 Suspension or revocation without hearing
- 9.30.230 Separate offense for each day
- 9.30.240 Public nuisance
- 9.30.250 Criminal penalties
- 9.30.260 Civil injunction
- 9.30.270 Administrative remedies
- 9.30.280 Severability

9.30.010 PURPOSE AND INTENT

It is the purpose and intent of this chapter to regulate cannabis businesses in order to promote the health, safety, morals, and general welfare of the residents and businesses within the City.

9.30.020 DEFINITIONS.

For the purpose of this chapter, the following definitions shall apply unless the context clearly indicates or requires a different meaning.

APPLICANT. A person who is required to file an application for a permit under this chapter, including an individual owner, managing partner, officer of a corporation, or any other agent of a cannabis business.

CANNABIS. All parts of the plant *Cannabis sativa* Linnaeus, *Cannabis indica*, or *Cannabis ruderalis*, or any other strain or varietal of the genus *Cannabis* that may exist or hereafter be discovered or developed that has psychoactive or medicinal properties, whether growing or not, including the seeds thereof. “Cannabis” also means cannabis as defined by § 11018 of the Health and Safety Code and by other state law. “Cannabis” does not mean “industrial hemp” as defined by § 11018.5 of the Health and Safety Code.

CANNABIS BUSINESS. An entity engaged in the cultivation, manufacture, distribution, processing, storing, laboratory testing, packaging, labeling, transportation, delivery or sale of cannabis and cannabis products for commercial purposes.

CANNABIS MANUFACTURING: The production, preparation, propagation, or compounding of cannabis or cannabis products either directly or indirectly or by extraction methods, or independently by means of chemical synthesis, or by a combination of extraction and chemical synthesis at a fixed location that packages or repackages cannabis or cannabis products or labels or relabels its container.

CANNABIS OPERATOR or OPERATOR. The person or entity that is engaged in the conduct of any commercial cannabis business.

CANNABIS PRODUCT. Cannabis that has undergone a process whereby the plant material has been transformed into a concentrate, including, but not limited to, concentrated cannabis, or an edible or topical product containing cannabis or concentrated cannabis and other ingredients.

CANNABIS RETAIL. A cannabis business where cannabis or cannabis products are offered, either individually or in any combination, for retail sale directly to customers. The primary use of a cannabis retail business is to sell products directly to on-site customers. Sales may also be conducted by delivery. Also known as a cannabis “dispensary.”

CANNABIS RETAIL – DELIVERY ONLY. A cannabis business that is closed to the public and conducts sales exclusively by delivery.

CHIEF OF POLICE. The Chief of Police of the City of Fort Bragg or the authorized representatives thereof.

CLONE. A portion of a stem that is cut from a parent plant and induced to form roots by chemical, mechanical, or environmental manipulations.

COMMERCIAL CANNABIS CULTIVATION. The planting, growing, harvesting of cannabis plants that are intended to be transported, processed, distributed, dispensed, delivered or sold.

COMMUNITY DEVELOPMENT DIRECTOR. The Director of the Community Development Department of the City of Fort Bragg or the authorized representatives thereof.

EDIBLE CANNABIS PRODUCT. A cannabis product that is intended to be used, in whole or in part, for human consumption, including, but not limited to, chewing gum, but excluding products set forth in Division 15 (commencing with § 32501) of the Food and Agricultural Code.

FULLY ENCLOSED AND SECURE STRUCTURE (FESS). A building or a space within a building that complies with the California Building Code, that has a complete roof enclosure supported by connecting walls extending from the ground to the roof, a foundation, slab or

equivalent base to which the floor is secured by bolts or similar attachments, is secure against unauthorized entry, and is accessible only through one or more lockable doors. Walls and roofs must be constructed of solid materials that cannot be easily broken through. Plastic sheeting, regardless of gauge, or similar products do not satisfy this requirement. If indoor grow lights or air filtration systems are used, they must comply with all applicable Building, Electrical, and Fire Codes.

GREENHOUSE. A completely enclosed structure whose structure members are made of pre-formed, rigid construction materials. The walls, roof, and ends are typically covered using a transparent material, often glass, that is fixed in place and which allows solar radiation to penetrate the surface and affect the growing environment of the plants inside.

HOOP HOUSE. A structure with structure members made of flexible and somewhat rigid construction materials, typically pvc pipe or similar material. The ends may be covered or left open and the material covering the structural members is readily removable and is typically removed and re-affixed frequently.

IMMATURE PLANT OR IMMATURE. A cannabis plant that has a first true leaf measuring greater than one half inch long from base to tip (if started from seed) or a mass of roots measuring greater than one half inch wide at its widest point (if vegetatively propagated), but which is not flowering.

INDOORS or INDOOR CULTIVATION. The cultivation of cannabis within a fully enclosed and secure structure. This includes mixed-light or greenhouse cultivation within a Fully Enclosed and Secure Structure.

MATURE PLANT OR MATURE. A cannabis plant that is flowering.

MULTI-TIER CULTIVATION. A cultivation that uses interior fixtures or shelving to cultivate multiple levels of plants within a FESS.

NURSERY. All activities associated with producing clones, immature plants, seeds, and other agricultural products used specifically for the propagation and cultivation of cannabis.

OUTDOOR or OUTDOOR CULTIVATION. Any cultivation that is not within a fully enclosed and secure structure. This includes hoop houses, and other structures that do not meet the definition of a Fully Enclosed and Secure Structure.

PERMITTEE. A person who holds an effective and current permit under this chapter.

PROCESS AND PROCESSING. All activities associated with the drying, curing, grading, trimming, rolling, storing, packaging, and labeling of cannabis or non-manufactured cannabis products.

RETAIL CANNABIS – DELIVERY ONLY. The commercial transfer of cannabis or cannabis products to a consumer. “Delivery” also includes the use of any technology platform owned

and controlled by a cannabis business operator that enables customers to arrange for or facilitate the commercial transfer by a permitted cannabis retail facility.

VOLATILE SOLVENT. Any solvent that is or produces a flammable gas or vapor that, when present in the air in sufficient quantities, will create explosive or ignitable mixtures. Examples of volatile solvents include, but are not limited to, butane, hexane, and propane.

9.30.030 LIMITATIONS ON USE.

A. Compliance with City Code. Cannabis businesses shall only be allowed in compliance with this chapter and all applicable regulations promulgated by the City of Fort Bragg, including but not limited to all regulations governing building, grading, plumbing, septic, electrical, fire, hazardous materials, nuisance, and public health and safety.

B. Compliance with State Laws and Regulations. Cannabis businesses shall comply with all applicable state laws and regulations, as may be amended, including all permit, approval, inspection, reporting and operational requirements, imposed by the state and its regulatory agencies having jurisdiction over cannabis and/or cannabis businesses. All cannabis businesses shall comply with the rules and regulations for cannabis as may be adopted and as amended by any state agency or department including, but not limited to, the Bureau of Cannabis Control, the Department of Food and Agriculture, the Department of Public Health, the Department of Pesticide Regulation, and the Board of Equalization.

C. Cannabis businesses shall provide copies of state, regional and local agency permits, approvals or certificates upon request by the City to serve as verification for such compliance.

D. Cannabis business permits are only valid for one year from date of issue but may be renewed as set forth in this chapter.

E. Cannabis business permits are discretionary and valid only for the cannabis business activities specified on the approved permit.

9.30.040 CANNABIS BUSINESSES PERMIT.

A. It shall be unlawful for any person to engage in, conduct or carry on, or to permit to be engaged in, conducted or carried on, in or upon any premises in the City the commercial cultivation, processing, manufacture, distribution or retail sale of cannabis without a valid cannabis business permit from the City and a license from the State of California as herein required.

B. Cannabis businesses shall not be established or maintained except as authorized by the Inland Land Use and Development Code and/or the Coastal Land Use and Development Code, as applicable.

C. Dual Licensing. State law requires dual licensing at the state and local level for cannabis businesses. All cannabis operators shall therefore be required to obtain a cannabis license from the State of California, and shall comply at all times with all applicable state licensing

requirements and conditions. Cannabis businesses shall not be allowed to commence operations until the cannabis business can demonstrate that all necessary state licenses and agency permits have been obtained.

D. Failure to demonstrate dual licensing in accordance with this chapter shall be grounds for revocation of City approval. Revocation of a local permit and/or a state license shall terminate the ability of the cannabis business to operate until a new permit and/or state license is obtained.

9.30.050 APPLICATIONS.

Any application for a cannabis business permit shall be filed with the Community Development Department and may be filed concurrently with an application for a conditional use permit or a Business License Application. The application shall be made under penalty of perjury. Any application for a cannabis business permit shall include the following information:

- A. The full name, present address, and telephone number of the applicant;
- B. The address to which notice of action on the application and all other notices are to be mailed;
- C. Previous addresses for the past 5 years immediately prior to the present address of the applicant;
- D. Written proof that the applicant is over 21 years of age;
- E. Photographs for identification purposes (photographs shall be taken by the Police Department);
- F. A copy of all the Applicant's valid state cannabis license(s) or copy of the complete pending cannabis application(s) related to the permit;
- G. The cannabis business history of the applicant, including whether the applicant, in previously operating in any city, county, or state under permit, has had a permit revoked or suspended and, if so, the reason therefor;
- H. The name or names of the person or persons having the management or supervision of the cannabis business;
- I. Whether the person or persons having the management or supervision of the cannabis business have been convicted of a crime(s), the nature of the offense(s), and the sentence(s) received therefor;
- J. A security plan ensuring the safety of employees and visitors from criminal activity, including theft and unauthorized entry;

- K. A sketch or diagram showing the interior configuration of the premises, including a statement of the total floor area occupied by the cannabis business and the purpose and security of each room or area of operation;
- L. A diagram illustrating the use and coverage of security cameras, security lighting, and necessary access restrictions;
- M. A notarized statement by the property owner certifying under penalty of perjury that he or she has given consent to the applicant to operate a cannabis business at the location, or providing proof that the applicant owns the property;
- N. Detailed operating procedures, which shall include the following:
1. Proposed hours of operation;
 2. How the business will comply with applicable state regulations;
 3. Product safety and quality assurances;
 4. Record keeping procedures;
 5. Product recall procedures;
 6. A solid waste disposal plan, with certification that waste transport entities and disposal facilities have agreed to haul and receive solid waste produced by the cannabis business;
 7. Product supply chain information (cultivation, testing, transportation, manufacturing, packaging and labeling, etc.);
 8. An odor prevention plan, illustrating how the cannabis business will be consistent with § 17.30.080(J) and/or § 18.30.080(J). The odor prevention plan may include an odor absorbing ventilation and exhaust system or other measures to ensure the use does not produce odors which are disturbing to people of normal sensitivity residing or present on adjacent or nearby property or areas open to the public; and
 9. Other information as required by the Community Development Director or the Chief of Police as necessary to ensure the project's compliance with local, state and federal regulations;
- O. Applications for a permit to conduct commercial cannabis cultivation shall include the following additional elements:
1. Drawings and plan specifications for the exact location and exact size of the Fully Enclosed and Secure Structure where any cannabis will be cultivated including seeds, clones, immature, and mature plants. Specifications shall include any plans for multi-tier cultivation;
 2. A water usage plan that indicates the planned source of water, month by month annual usage in gallons, and any plans for water conservation which may include water recycling, on-site water storage, development of a well, or use of reclaimed city water;
 3. An energy plan that indicates the estimated monthly energy usage in kilowatt hours, the source(s) of energy, and any planned energy conservation practices including plans that utilize natural sunlight, solar panels, LED lighting, Sonoma Clean Power, or other methods to reduce energy consumption; and

4. Any other information required by the Community Development Department.

P. Authorization for the City, its agents and employees to seek verification of the information contained within the application; and

Q. A statement in writing by the applicant that he or she certifies under penalty of perjury that all the information contained in the application is true and correct.

9.30.060 TIME LIMIT FOR FILING APPLICATION FOR PERMIT.

If the applicant has completed the application improperly, or if the application is incomplete, the Community Development Director shall, within 30 days of receipt for the original application, notify the applicant of the fact and, on request of the applicant, grant the applicant an extension of time of 30 days or more to submit a complete application.

9.30.070 TERM OF PERMITS AND RENEWALS.

Cannabis business permits issued under this chapter shall expire one year following their issuance. Cannabis business permits may be renewed by the Community Development Director for additional one-year periods upon application by the permittee, unless the permit is suspended or revoked subject to § 9.30.190. Applications for renewal shall be made at least 45 days before the expiration date of the permit and shall be accompanied by the nonrefundable fee referenced in § 9.30.080. When made less than 45 days before the expiration date, the expiration of the permit will not be stayed. Applications for renewal shall be acted on as provided herein for action upon applications for permits. The Chief of Police may recommend to deny an application for renewal based on any of the grounds referenced in §§ 9.30.100 and 9.30.190. An applicant aggrieved by the Community Development Director's decision to deny a renewal of a cannabis business permit may appeal pursuant to § 9.30.110.

9.30.080 FEES.

Every application for a cannabis business permit or renewal shall be accompanied by a nonrefundable fee, as established by resolution adopted by the City Council from time to time. This application or renewal fee is in addition to fingerprinting, photographing, and background check costs and shall be in addition to any other permit fee imposed by this code or other governmental agencies. Fingerprinting, photographing, and background check fees will be as established by resolution adopted by the City Council from time to time.

A. The fee schedule is intended to allow recovery of all costs incurred by the City in processing permit applications to the maximum extent allowed by the law.

B. Timing of payment. No application shall be deemed complete, and processing shall not commence on any application until all required fees or deposits have been paid. Failure to timely pay supplemental requests for payment of required fees and/or deposits shall be a basis for denial or revocation of any permit.

C. Refunds and withdrawals. Application fees cover City costs for public hearings, mailings, staff time, and the other activities involved in processing applications. Therefore, no refund due to a disapproval shall be allowed. In the case of a withdrawal, the Director shall have the

discretion to authorize a partial refund based upon the pro-rated costs to date and the status of the application at the time of withdrawal.

9.30.090 PUBLIC SAFETY REVIEW AND ACTION ON APPLICATION.

After the application is deemed complete and the fees or deposits have been collected, the Community Development Director will send the completed application to the Chief of Police for Public Safety review. The Chief of Police or his designee shall conduct a background check of the applicant and conduct a public safety review of the proposed project. After the background checks and public safety review are complete, the Chief of Police or his designee shall formally recommend either approval or denial of the application.

If an application is recommended for denial by the Chief of Police or his designee, the Community Development Director shall not approve the application. The applicant will be notified by a letter sent by certified mail and will have 30 days to modify the existing application. If the application is not modified within 30 days and the applicant has not requested more time, it will be denied by the Community Development Director.

The Chief of Police or his designee may recommend conditional approval of an application with specific requirements that the applicant shall meet. The Community Development Director will require the fulfillment of the conditions prior to final issuance of the permit.

9.30.100 GROUNDS FOR DENIAL OF APPLICATION.

The grounds for a denial of a cannabis business permit application shall be one or more of the following:

- A. The business or conduct of the business at a particular location is prohibited by any local or state law, statute, rule, or regulation;
- B. The applicant has violated any local or state law, statute, rule, or regulation respecting a cannabis business;
- C. The applicant has knowingly made a false statement of material fact or has knowingly omitted to state a material fact in the application for a permit;
- D. The applicant, owner, or permittee has a criminal history that falls under the Business and Professional Code Section 26057(b)(4), 26057(b)(5), 26057(b)(6) or 26057(b)(7) with the exception of criminal activity that falls under Business and Professional Code Section 26059;
- E. The applicant has engaged in unlawful, fraudulent, unfair, or deceptive business acts or practices;
- F. The applicant is under 21 years of age;
- G. The cannabis business does not comply with Title 17 (Coastal Land Use Development Code) or Title 18 Inland Land Use and Development Code;

H. The required application or renewal fees have not been paid; or

I. The applicant's plan fails to comply with section 9.30.130 and, if applicable, section 9.30.140.

9.30.110 APPEAL FROM COMMUNITY DEVELOPMENT DEPARTMENT DECISION TO DENY APPLICATION.

The Community Development Director shall cause a written notice of decision to deny a cannabis business permit application to be mailed to the applicant by certified U.S. mail, postage prepaid, return receipt requested, to the address provided by the applicant for sending of notices. An applicant aggrieved by the decision to deny an application may appeal the decision in accordance with the procedures described in Chapter 1.08. If an appeal is not taken within such time (15 days), the Community Development Director's decision shall be final.

9.30.120 PROCESSING OF CANNABIS BUSINESS PERMIT.

If an application is recommended for approval by the Chief of Police, it shall be reviewed by the Community Development Director for:

1. Compliance with other required permits or licenses necessary prior to operation;
2. Compliance with all rules, regulations, ordinances and requirements of the City, including but not limited to Section 9.30.130 and if applicable, section 9.30.140; and
3. Compliance with the California Environmental Quality Act.

9.30.130 OPERATING REQUIREMENTS.

A cannabis business shall meet the following operating requirements for the duration of the use:

- A. The design, location, size and operating characteristics of the cannabis business shall comply with the findings and conditions of any applicable discretionary permit obtained for its operation;
- B. A cannabis business use shall maintain a current register of the names of all current owners and all current employees who will be on the premise;
- C. Individuals not listed as employees, owners, or managers of the business, shall not be permitted in non-public areas of the business;
- D. The building entrance to a cannabis business shall be clearly and legibly posted with a notice indicating that persons under the age of 21 are precluded from entering the premises unless they are a qualified patient or a primary caregiver and they are in the presence of their parent or legal guardian;
- E. No cannabis business shall hold or maintain a license from the State Department of Alcoholic Beverage Control to sell alcoholic beverages, or operate a business that sells alcoholic beverages. In addition, alcohol shall not be provided, stored, kept, located, sold, dispensed, or used on the premises of the cannabis business use;

F. A cannabis business shall provide adequate security on the premises, including lighting and alarms, to ensure the safety of employees and visitors from criminal activity, including theft and unauthorized entry; and

G. A cannabis business shall provide the Chief of Police and Fire Chief with the name, phone number, and facsimile number of an on-site community relations staff person to whom one can provide notice if there is an emergency or there are operating problems associated with the cannabis business. The cannabis business management shall make every good faith effort to encourage residents to call this person to try to solve operating problems, if any, before any calls or complaints are made to the Police or Community Development Department.

9.30.140 COMMERCIAL CANNABIS CULTIVATION.

A. Commercial Cannabis shall be cultivated only in a Fully Enclosed and Secured Structure (FESS). Commercial cannabis cultivation that occurs within a greenhouse that meets the criteria for a FESS shall not be visible from any public right of way.

B. Commercial Cannabis Cultivation shall be reviewed for compliance with the California Environmental Quality Act.

C. Commercial cannabis cultivation shall utilize on-site water recycling practices.

D. Commercial cannabis cultivation shall either enroll in Sonoma Clean Power or install solar panels.

9.30.150 MINORS.

A. It shall be unlawful for any permittee, operator, or other person in charge of any cannabis business to employ any person who is not at least 21 years of age.

B. Persons under the age of 21 shall not be allowed on the premises of a cannabis business unless they are a qualified patient or a primary caregiver and they are in the presence of their parent or legal guardian.

9.30.160 DISPLAY OF PERMIT.

Every cannabis business shall display at all times during business hours the permit issued pursuant to the provisions of this chapter for cannabis businesses in a conspicuous place so that the same may be readily seen by all persons entering the cannabis business.

9.30.170 REGISTRATION OF NEW EMPLOYEES.

A. As a further condition of approval of every cannabis business permit issued pursuant to this chapter, every owner or operator shall register every employee with the Police Department within ten business days of the commencement of the employee's period of employment at the cannabis business.

B. The owner or operator will submit a color copy of the new employee's photo identification card as part of the registration process. Upon request from the Police Department, the employee shall provide their original photo identification card for review.

C. The Police Department shall be notified within ten business days of any employee no longer employed by the business and the owner shall provide an updated roster of all current employees. The roster shall be dated and signed by the owner or operator declaring that it is complete.

D. Failure to register each new employee within ten days of the commencement of employment or to maintain a current register of the names of all employees shall be deemed a violation of the conditions of the permit and may be considered grounds for suspension or revocation of the permit.

9.30.180 TRANSFER OF PERMITS.

A. A permittee shall not operate a cannabis business under the authority of a Cannabis Business Permit at any place other than the address or parcel of the cannabis business stated in the application for the permit.

B. A permittee shall not transfer ownership or control of a cannabis business or transfer a Cannabis Business Permit to another person unless and until the transferee obtains an amendment to the permit from the Community Development Director or Chief of Police stating that the transferee is now the permittee. The amendment may be obtained only if the transferee files an application with the Community Development Director in accordance with § 9.30.050, accompanies the application with a transfer fee in an amount set by resolution of the City Council, and the Chief of Police determines in accordance with § 9.30.090 that the transferee would be entitled to the issuance of an original permit.

C. No permit may be transferred when the Community Development Director has notified the permittee that the Permit has been or may be suspended or revoked.

D. Any attempt to transfer a Permit either directly or indirectly in violation of this section is hereby declared void, and the permit shall be deemed revoked.

9.30.190 SUSPENSION AND REVOCATION – NOTICE.

A. Any permit issued under the terms of this chapter may be suspended or revoked by the Chief of Police or the Community Development Director when it appears to them that the permittee has committed any one or more of the acts or omissions constituting the grounds for suspension or revocation under this chapter.

B. No permit shall be revoked or suspended by virtue of this section until a hearing has been held by the City. Written notice of the time and place of the hearing shall be served upon the person to whom the permit was granted at least 5 days prior to the date set for the hearing. The notice shall contain a brief statement of the grounds to be relied upon for revoking or suspending the permit. Notice may be given either by personal delivery to the permittee or by

depositing it in the U.S. mail in a sealed envelope, postage prepaid, addressed to the permittee at the address provided by the permittee for sending of notices.

9.30.200 SUSPENSION AND REVOCATION – GROUNDS.

It shall be a ground for suspension or revocation of a permit if any permittee or person, his or her agent, or employee:

- A. Does any act which violates any of the grounds set forth in § 9.30.100, which sets forth the grounds for denial of an application for a permit for the cannabis business;
- B. Violates any other provision of this chapter or any local or state law, statute, rule, or regulation relating to his or her permitted activity;
- C. Conducts the permitted business in a manner contrary to the peace, health, or safety of the public;
- D. Fails to take reasonable measures to control the establishment's patrons' conduct resulting in disturbances, vandalism, or crowd control problems occurring inside of or outside the premises, traffic control problems, or creation of a public or private nuisance, or obstruction of the business operation of another business;
- E. Violates any provision of Title 15 of this Code; or
- F. Violates or fails to comply with the terms and conditions of any required discretionary permit.

9.30.210 SUSPENSION AND REVOCATION – APPEALS.

Any permittee aggrieved by the decision of the City in suspending or revoking a permit may, within 15 calendar days, appeal the decision in accordance with the procedures described in Chapter 1.08. If a decision of the City to suspend or revoke a permit is not appealed within 15 calendar days, the decision of the City shall be final.

9.30.220 SUSPENSION OR REVOCATION WITHOUT HEARING.

If any person holding a permit or acting under the authority of the permit under this chapter is convicted of a misdemeanor in any court for the violation of any law which relates to his or her permit, the Chief of Police shall revoke the permit forthwith without any further action thereof, other than giving notice of revocation to the permittee. If a permit is summarily revoked pursuant to the provisions of this section, a permittee may, within 15 calendar days, appeal the revocation in accordance with the procedures described in Chapter 1.08. During the pendency of the appeal, the permit shall be deemed suspended. If the appeal is not taken within 15 days, the decision of the Chief of Police shall be final.

9.30.230 SEPARATE OFFENSE FOR EACH DAY.

Any person that violates any provision of this chapter shall be guilty of a separate offense for each and every day during any portion of which any such person commits, continues, permits, or causes a violation thereof, and shall be penalized accordingly.

9.30.240 PUBLIC NUISANCE.

Any use or condition caused or permitted to exist in violation of any of the provisions of this chapter shall be and is hereby declared a public nuisance and may be abated by the City pursuant to Chapter 6.12.

9.30.250 CRIMINAL PENALTIES.

Any person who violates, causes, or permits another person to violate any provision of this chapter commits a misdemeanor.

9.30.260 CIVIL INJUNCTION.

The violation of any provision of this chapter shall be and is hereby declared to be a public nuisance and contrary to the public interest and shall, at the discretion of the City, create a cause of action for injunctive relief.

9.30.270 ADMINISTRATIVE REMEDIES.

In addition to the civil remedies and criminal penalties set forth above, any person that violates the provisions of this chapter may be subject to administrative remedies, as set forth by City ordinance.

9.30.280 SEVERABILITY.

If any section, subsection, sentence, clause, or phrase of this chapter is for any reason held by a court of competent jurisdiction to be invalid or unconstitutional, the decision shall not affect the validity of the remaining portions of this chapter. The City Council of the City hereby declares that it would have passed the ordinance codified in this chapter and each section, subsection, sentence, clause, and phrase thereof irrespective of the fact that one or more sections, subsections, sentences, clauses, or phrases may be held invalid or unconstitutional.

Section 3. Effective Date and Publication. This ordinance shall be and the same is hereby declared to be in full force and effect from and after thirty (30) days after the date of its passage. Within fifteen (15) days after the passage of this Ordinance, the City Clerk shall cause a summary of said Ordinance to be published as provided in Government Code §36933, in a newspaper of general circulation published and circulated in the City of Fort Bragg, along with the names of the City Council voting for and against its passage.

The foregoing Ordinance was introduced by Councilmember _____ at a regular meeting of the City Council of the City of Fort Bragg held on May 10, 2021 and adopted at a regular meeting of the City of Fort Bragg held on May 24, 2021 by the following vote:

- AYES:**
- NOES:**
- ABSENT:**
- ABSTAIN:**
- RECUSED:**

BERNIE NORVELL
Mayor

ATTEST:

June Lemos, CMC
City Clerk

PUBLISH: May 13, 2021 and June 3, 2021 (by summary).
EFFECTIVE DATE: June 23, 2021.

Lemos, June

From: Jacob Patterson <jacob.patterson.esq@gmail.com>
Sent: Monday, May 10, 2021 1:08 PM
To: Gurewitz, Heather
Cc: Lemos, June
Subject: Comment re minor corrections to the ordinance for Item 8A

City Council and Staff,

Overall, the suggested revisions to our code seem good to me. However, there is a typo in the ordinance tonight that probably should be corrected prior to introduction. The ordinance references Business & Professions Code sections but in 9.30.100(D) the references are incorrect because they say "Professional" instead of "Professions," which is a very frequent typo--one I have made on numerous occasions.

In addition, the draft ordinance in 9.30.100(D) only lists 26057(b)(4), 26057(b)(5), 26057(b)(6) or 26057(b)(7) as the types of criminal convictions that are grounds for denial but the state regulations for licenses found in Business and Professions Code section 26057 also includes 26057(b)(2), which is a cross reference to other criminal convictions that are grounds for denial of a cannabis license. As such, this local code section should also reference 26057(b)(2) to follow the majority direction to mimic the state requirements regarding types of criminal convictions. (Subpart (b)(5), which is included in the draft ordinance, relates and refers to (b)(2) so it doesn't make sense to include one without the other.) Technically, 26057 is a single code section so we don't need to list the "26057" for each of the subparts of subdivision (b) of section 26057. Moreover, there is no practical effect in leaving out (b)(1), (b)(3), (b)(8), or (b)(9) even though those parts don't concern criminal background so you could just reference all of section 26057 without identifying the particular subparts. As a result, I think the best way to follow the state regulations is to just reference all of Section 26057.

As an aside, I would have left the applicability as it read before ("The applicant, his or her agent, or any person who is exercising managerial authority on behalf of the applicant") with the new "owner, or permittee" tacked on since the majority direction was to make sure it didn't extend to employees but I don't recall the City Council saying the prohibitions concerning criminal background shouldn't still apply to managers. Of course, this is a different issue than swapping out the code references in place of the prior local list of disqualifications, which definitely followed the majority direction as reflected in my notes. This draft ordinance took the "applicant, owner, or permittee" from 26057(b)(4) but the state doesn't use that language for all of the disqualifying categories, which have different applicability. To illustrate, (b)(4) applies to the specific parties we list in this draft but the other listed subparts have different lists or applicable parties, including (b)(6) and (b)(7) which apply to "The applicant, or any of its officers, directors, or owners" so it makes sense to make some minor revisions to this proposed code provision.

My total suggested revisions to 9.30.100(D) are as follows, with three alternatives, the first of which is the most clear and accurate, IMO:

"D. The applicant, owner, permittee, his or her agent, or any person who is exercising managerial authority on behalf of the applicant has a criminal history that falls under Business and Professions Code Section 26057 with the exception of criminal activity that falls under Business and Professions Code Section 26059;"

"D. The applicant, owner, permittee, his or her agent, or any person who is exercising managerial authority on behalf of the applicant has a criminal history that falls under the Business and Professions Code Section 26057,

subdivisions (b)(2), (b)(4), (b)(5), (b)(6), or (b)(7), with the exception of criminal activity that falls under Business and Professions Code Section 26059;"

"D. The applicant, owner, permittee, his or her agent, or any person who is exercising managerial authority on behalf of the applicant has a criminal history that falls under Business and Professions Code Section 26057(b)(2), 26057(b)(4), 26057(b)(5), 26057(b)(6), or 26057(b)(7) with the exception of criminal activity that falls under Business and Professions Code Section 26059;"

If we specifically don't want to include managers, then the entire thing could be shortened to just say "the applicant" or "the relevant parties identified in Business and Professions Code section 26057" to ensure applicability parallel to the state regulations.

Thanks,

--Jacob

Lemos, June

From: Jenny Shattuck <jenxvann@yahoo.com>
Sent: Monday, May 10, 2021 6:33 PM
To: Lemos, June
Subject: 8A public comment

I am confused about 9.30.140 This seems like it should be in the inland land use and development code update, with the rest of the cannabis cultivation regulations, instead of the cannabis business license section as purposed. *I can not hear anything happening currently by anyone in city hall so am I submitting this comment early because it is unclear what is happening, closed captioning is not giving exact words so perhaps this item can be continued if sound is not fixed so all can participate.*

Jenny Shattuck



City of Fort Bragg

416 N Franklin Street
Fort Bragg, CA 95437
Phone: (707) 961-2823
Fax: (707) 961-2802

Text File

File Number: 21-217

Agenda Date: 5/10/2021

Version: 1

Status: Business

In Control: City Council

File Type: Staff Report

Agenda Number: 8B.

Receive Report and Consider Two Requests for a Waiver of the Fee to Appeal a Planning Commission Decision to the City Council



AGENCY: City Council
MEETING DATE: May 10, 2021
DEPARTMENT: City Manager
PRESENTED BY: Tabatha Miller
EMAIL ADDRESS: tmiller@fortbragg.com

AGENDA ITEM SUMMARY

TITLE:

Receive Report and Consider Two Requests for a Waiver of the Fee to Appeal a Planning Commission Decision to the City Council

ISSUE:

On Monday, April 26, 2021, staff received two separate appeals of the Planning Commission approval of the Coastal Development Permit 3-20 (CDP 3-20) to upgrade a section of State Route 1 to current Americans with Disabilities Act (ADA) standards. The Planning Commission decision (3-1) was April 14, 2021 and both appeals were received within ten (10) days of the decision by parties that met the definition of aggrieved person, as each had provided public comment at the Planning Commission hearing.^{1, 2}

Prior to receiving the appeal request from Ms. Tiffani Ferris, Ms. Ferris delivered a letter (Attachment 1) to the City Manager requesting a waiver of the \$1,000 appeal fee. The City Manager reached out to Ms. Ferris to explain that there were no provisions in the Coastal Land Use and Development Code (CLUDC) for the City Manager to waive the fee but a request could be made to the City Council. The City Manager agreed that Ms. Ferris could file the appeal on April 26 without the fee, but if the City Council did not waive it that evening, the fee must be paid Tuesday morning for the appeal to be complete. Ms. Ferris paid the \$1,000 fee when she delivered the appeal to City Hall Monday, but requested the refund from City Council during public comments on non-agenda items at the regular City Council meeting that same day.

As the item was not on the agenda, City Council did not take action on the request. The Council was advised that to consider the item, four-fifths of Councilmembers would need to vote to determine that there was an urgent need for immediate action.³ As the appeal fee had been paid and Ms. Ferris's ability to appeal secured, the Council requested staff place the waiver request on an agenda for a future Council meeting and did not take a roll call vote to determine if the request was urgent.

The \$1,000 fee for the second appeal, filed by the Albion Bridge Stewards, Annemarie Weibel and Gabriel Quinn Maroney was received and Ms. Weibel has requested a refund of that fee on behalf of these appellants.

¹ The tenth day fell on April 24, 2021, which was a Saturday. As a result, the appeals were due on the next business day, which was Monday, April 26, 2021.

² Aggrieved Person is anyone who, in person or through an explicitly identified representative, appeared at a public hearing before the Director, Commission, or Council in connection with the decision or appeal of any development, or who by other appropriate means before a hearing, informed the City of the nature of their concerns, unless for good cause was unable to do either. [Section 17.92.040\(A\)2 CLUDC](#).

³ [California Government Code section 54954.2\(b\)](#).

ANALYSIS:

An aggrieved person, may file an appeal from any decision following a public hearing. The Coastal Land Use and Development Code (CLUDC) Section 17.92.030(B) provides:

B. Timing and form of appeal. *An appeal shall be submitted in writing and shall specifically state the pertinent facts and the basis for the appeal.*

1. An appeal shall be filed with the Department or City Clerk, as applicable, within 10 days of the date the decision was rendered.

a. Appeals addressed to the Commission shall be filed with the Department;

b. Appeals addressed to the Council shall be filed with the City Clerk.

2. An appeal shall be accompanied by the filing fee identified in the City's Fee Schedule.

3. The appeal fee may be refunded by a majority vote of the Council if the appeal of the applicant is sustained by the Council.

The CLUDC⁴ does not provide a means for an appellant to request a waiver of the appeal fee prior to the appeal. It does provide that the City Council may by a majority vote refund the fee, if the applicant's appeal is successful.

An aggrieved person, as defined, may also appeal to the Coastal Commission without a fee. The City's CLUDC does not require an appellant to exhaust all local appeals before appealing directly to the Coastal Commission. Both section 17.92.040(B)(2) of the Fort Bragg CLUDC and the Coastal Act allow for appeal to the Coastal Commission without having to exhaust all local appeals if the local government charges a fee to appeal. The City charges \$1,000 to appeal a Planning Commission decision to City Council. There is no charge to appeal a decision to the Coastal Commission.

Separate and distinct from planning permit decisions, the Fort Bragg Municipal Code does have a provision that allows the City Manager to waive processing fees for appeals associated with administrative decisions. Section 1.08.010 (C) provides in part:

No appeal hearing shall proceed without payment of the processing fee and deposit of the administrative penalty, if any, with the City Clerk at the time the Request for Hearing is filed; provided, however, that the City Manager may waive or defer the processing fee upon written request for good cause shown. Good cause may include severe economic hardship, significant attempts and/or good faith efforts to address and remedy the subject matter of any administrative penalty or hearing [emphasis added].

The more flexible discretion provided to the City Manager to determine good cause to waive payment of processing fee and deposit of the administrative penalty was the subject of a recent claim for damages and characterized as "arbitrary and capricious."⁵ Hence, it is

⁴ The ILUDC's provisions for appeal are almost identical and do not have a provision for waiving a fee prior to the outcome of final decision on the appeal.

⁵ The processing was paid and the appeal will be scheduled before an impartial third party hearing officer.

important that the City Council consider the precedent and effect that waiving or not waiving these fees will have on future requests for fee waivers. While discretion in making such decisions ensures that individuals have access to appeals and all facts may be considered, it does leave such actions open to allegations of unfairness or worse.

A fee can be an insurmountable financial barrier to an individual's ability to protect an interest. However, the fee also serves to cover the cost of the right to challenge an agency's decision and to ensure that the party bringing the appeal has a legitimate interest in the outcome. The challenge with considering economic hardship alone without considering the merits of the appeal or the interest that may be adversely affected by the agency decision, is that the taxpayers bear the costs of those appeals that may be unsuccessful or even meritless. Further, if economic hardship is the only factor considered, certain parties have free access to appeal any future decision. An aggrieved party does not have to be a resident of the City, County or even the State, but just needs to have participated in the public hearing process.

These considerations may be the basis for the ILUDC and CLUDC requirement that the appellant's challenge be decided and successful prior to deciding if the fee should be waived. It is important to note that an aggrieved person has had an opportunity to participate in the decision by providing public input (in written and/or verbal comments) before and during the original hearing.

The City Council establishes fees for hearings and appeals through approval of the City's Fee Schedule. The Council policy is to collect the reasonable cost of providing a service to the particular user(s) of that service. This has required the appellant, requesting the appeal, to pay at least a portion of the costs of conducting a hearing. The City Council may reduce, eliminate or consider waiving fees based on other policy reasons and could choose to shift the cost of waiving fees from the taxpayers to the permit applicant.

RECOMMENDED ACTION:

Determine whether an appeal fee waiver or fee reduction is appropriate for the parties requesting such waivers.

ALTERNATIVE ACTION(S):

Provide staff direction to revise the City's Fee Schedule based on alternative policy considerations. For example, the City Council could reduce appeal fees, eliminate appeal fees or create an established set of criteria for when it is appropriate to charge a lesser fee or no fee.

FISCAL IMPACT:

The following is an estimate for the costs associated with conducting an Appeal Hearing for CDP 3-20.

Expense	Amount	
Mailing Hearing Notice Postage (350 X .55)	\$	193.00
Staff Time Processing Public Notice (3 Sf X .75 hour)		99.00
Advocate Charge for Publishing Hearing Notice		275.00
Processing Appeal City Clerk Staff Time (1 Hour)		54.00
Appeal Staff Report - M-Group (10 hours + 2 hours)		1,740.00
City Attorney Time (3 hours + 2 hours)		1,025.00
City Council Hearing Staff Time (2 hours)		414.00
	\$	3,800.00

GREENHOUSE GAS EMISSIONS IMPACT:

N/A

CONSISTENCY:

N/A

IMPLEMENTATION/TIMEFRAMES:

Processing a fee refund may take up to two weeks, depending on the Accounts Payable Check schedule.

ATTACHMENTS:

1. Ferris Fee Waiver Request

NOTIFICATION:

1. Tiffani Ferris
2. Annemarie Weibel

REC'D APR 22 2021

Dear Tabitha Miller,

My name is Tiffani Ferris, I am the mother of Lilli Varela. Lilli has been confined to a wheelchair since a young child. I spoke at the planning commission meeting asking that both sides of the dangerous and inaccessible intersection at Cypress street and the area from Oak street south to the chamber of commerce building be included in the new Caltrans project to make Main street accessible to people like Lilli.

It is not safe for people, especially people like Lilli to cross the Cypress street intersection as the crosswalks pretty much ends and there is no way for someone in a wheelchair to continue on without being in traffic.

I am submitting an appeal to the Fort Bragg city council on behalf of Lilli and am asking for a waiver of the appeal fee. As a household that is limited to disability income the appeal fee is unattainable. As a mother of a disabled young adult who represents many in our community, I am asking for the basic ability to safely access our coastal trail. The appeal is asking for the council to add the special condition that the crosswalk ending on the east side of Cypress be accessible as well as the need for an accessible path from the curb to the entrance gate of the city park.

I do not want to have to appeal to the Coastal Commission because I do not want to delay this much needed project, I would rather this be dealt with locally.

Thank you,
Tiffani Ferris
558 South Sanderson Way
Fort Bragg, Ca

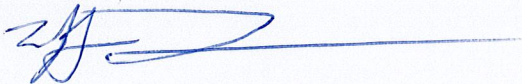

From: [Ona Rynearson](#)
To: [Lemos, June](#)
Subject: Item 8B
Date: Monday, May 10, 2021 8:49:31 AM

To whom it may concern,

I am writing in regards to item 8B on tonight's agenda. Please waive the appeal fees for Tiffani Ferris for her appeal concerning ADA accessibility improvements to Highway 1.

I am a little distraught and disappointed that our county charges so much for an appeal to begin with - and that there is not an easy way to have a waiver during application for low-income residents of the county who need to pursue these concerns. This is an issue the county should consider addressing in the future.

Sincerely,
Ona Rynearson
130 W Spruce Street
Fort Bragg, CA 95437

From: Gabriel Maroney <gabrielquinn@sbcglobal.net>
Sent: Monday, May 10, 2021 2:26 PM
To: Lemos, June
Subject: Conduct of Business 8B comment.

Dear Honorable City Council,

regarding Conduct of Business 8B: Receive Report and Consider Two Requests for a Waiver of the Fee to Appeal a Planning Commission Decision to the City Council:

I understand the expense can be substantial for an appeal which is important to consider, however the process is often an extremely important and often a stress test for projects. I trust that the council appreciates the work done by our great community in good faith. Please do not make the mistake of judging appeals as arbitrary or something to be overcome, but instead an invaluable resource of public partnership that engenders a more holistically appropriate governance. It is also important to understand that the appeal/waiver process can be confusing due to inconsistencies and that multiple elements should probably be considered along with the merit of the appeal determined on a case by case discovery. With this project, there are concerns echoed that governing coastal and city guidelines had not been followed; nor enough time given for proper assessment.

Personally I have taken more interest in this project due to disabled experience from vehicle accident. Perhaps if it is the judgment of the council to waive the appeal fee it could be charged to Cal Trans as their project plan was/is extremely wanting and they are one of the most funded institutions in California.

Thank you in appreciation,
Gabriel Quinn Maroney

Dear City Council members,

Tiffany Ferris and I both spoke at the April 26, 2021 City Council meeting (public comments non agenda items) about the appeal of the Caltrans ADA project. Tiffany Ferris indicated that she asked the City Manager to wave the appeal fee for her/her daughter's appeal.

I, Annemarie Weibel, mentioned why we believe that the appeal by the Albion Bridge Stewards, Gabriel Quinn Maroney and I was necessary. The action of the Planning Commission on April 14, 2021 was inconsistent with the applicable mandatory review standards of the Local Coastal Plan (LCP), and the Coastal Act.

I also indicated an interest (on behalf of the appellants of our appeal) to have the appeal fee refunded. In our appeal letters we stated that as well.

We did not submit a formal fee waiver request for today's meeting as we want for you to be able to read the appeal letters, study all the documents including the public comments and deliberate on the merit of the appeal first.

Thank you so much.

Sincerely,
Annemarie Weibel

5-10-2021



City of Fort Bragg

416 N Franklin Street
Fort Bragg, CA 95437
Phone: (707) 961-2823
Fax: (707) 961-2802

Text File

File Number: 21-216

Agenda Date: 5/10/2021

Version: 1

Status: Business

In Control: City Council

File Type: ID Resolution

Agenda Number: 8C.

Receive Report and Consider Adoption of Municipal Improvement District Resolution Approving Budget Amendment No. 2021-10 Adjusting Selected Expenditure and Revenue Budgets



AGENCY: Municipal Improvement Dist.
MEETING DATE: May 10, 2021
DEPARTMENT: Public Works
PRESENTED BY: J. Smith
EMAIL ADDRESS: jsmith@fortbragg.com

AGENDA ITEM SUMMARY

TITLE:

Receive Report and Consider Adoption of Municipal Improvement District Resolution Adopting Budget Amendment #2021-10 Amending Selected Expenditure Budgets

ISSUE:

The Wastewater Treatment Plant Upgrade Project construction contract was awarded on May 14, 2018. Switchover to the new treatment system was complete April 2020. The first year of operation has provided good data on performance of the treatment process and is producing an exceptional product. The result of this efficient process is an increase in biosolids storage causing an odiferous condition which is impacting our Coastal Trail users.

ANALYSIS:

For many years, the City has been working toward ways to reuse treated products at the wastewater facility. Recycling the water and biosolids is important in our community to reduce our environmental footprint. In the coming years, our goal to reuse treated products may come to fruition. Prior to the newly upgraded wastewater treatment facility coming on line, this wasn't an option. The old treatment process was a good system that treated the sewage well and was within the required water quality requirements set forth by our National Pollutant Discharge Elimination System (NPDES) Permit. The new system greatly reduces our carbon footprint and the core treatment process further reduces solids from our discharge. The result is greater treatment of the effluent which increases the solids removal, producing a larger volume of biosolids to dispose of. The increased removal is great as we push into the future. Some folks may not agree due to the smell when walking or riding by the wastewater facility.

The new treatment train is able to remove a greater amount of solids than was forecast, thereby increasing the amount of solids on site. The City currently transports the solids year round via a contractor who land applies the product at permitted locations in the Sacramento area and provides 100% reuse of our solids. This is a great first step, but we need to reduce or eliminate transport cost and work toward reusing the solids in our community.

Staff studied several biosolid treatment units that would significantly reduce transport cost, produce a class A biosolid product that we can reuse, fit the unit within the existing property and requires little to no maintenance. The search began in September of last year. In March we had identified several different treatment options that would work. The USA Sludge unit answered our list of requirements and included the lowest price and a performance guarantee. If approved for purchase, the dryer is expected to be delivered 21 weeks after placing the order. In the meantime, staff has identified a couple products that are added to our treatment system to further reduce solids volume and combat odor. The first of these products was introduced to our treatment process four weeks ago and we have included another that will further reduce smell. Additionally, staff will limit transfer of the biosolids to late evening to minimize impact on Coastal Trail users.

The top four dryers are listed below:

- ELODE – Electro Osmosis Dehydrator (\$763,000)
 - Uses electro-osmosis and electrophoresis process. Not chosen due to price and maintenance cost.
- HUBER – Solar drying system. (\$2,190,000)
 - This unit is not expected to produce a class A product and the structure footprint will not fit on the existing parcel.
- SHINCCI – Low Temperature Dehumidification Solids Treatment System (\$587,000)
 - The Shincci required higher energy use and higher unit cost than the USA Sludge unit.
- USA Sludge - Low Temperature Dehumidification Solids Treatment System (\$539,800)
 - This company provided a performance guarantee and provides a class A product at the lowest cost.



The USA dryer is capable of producing a Class A granular product by heating the biosolids, accomplishing a 90 percent total solids content. The temperature and total solids content values are in accordance with U.S. Environmental Protection Agency (EPA) Clean Water Act, Part 503 rule regarding land application of biosolids; those biosolids meeting the Class A requirement have less stringent regulations for reuse and disposal.

RECOMMENDED ACTION:

Approve the budget amendment for the purchase of biosolids dryer to reduce transportation cost to the Municipal Improvement District.

ALTERNATIVE ACTION(S):

Deny request.

FISCAL IMPACT:

The annual budget for biosolids removal is expected to decrease conservatively by \$150,000-\$200,000. This piece of equipment is expected to pay for itself in three years.

IMPLEMENTATION/TIMEFRAMES:

Order unit after approval of budget amendment.

ATTACHMENTS:

1. Resolution for Budget Adjustments
2. Exhibit A - Budget Amendments
3. Dryer Proposals (SHINCCI)
4. Sodium Hypochlorite quote (Univar)

NOTIFICATION:

None.

RESOLUTION NO. ID __-2021

RESOLUTION OF THE FORT BRAGG MUNICIPAL IMPROVEMENT DISTRICT APPROVING BUDGET AMENDMENT 2021-10 AMENDING FISCAL YEAR 2020-21 BUDGET FOR MID-YEAR BUDGET ADJUSTMENTS

WHEREAS, on June 29, 2020, the Fort Bragg City Council and the Fort Bragg Municipal Improvement District No. 1 District Board adopted the Fiscal Year (FY) 2020-21 Budget; and

WHEREAS, the City Manager continues to review and revise the budget; and

WHEREAS, the City Manager has identified updated revenue projections, additional expenditure adjustments and corrections to the FY 2020-21 budget as adopted by the City Council on June 29, 2020; and

WHEREAS, those adjustments are identified in Exhibit A attached hereto; and

WHEREAS, based on all the evidence presented, the City Council finds as follows:

1. Certain adjustments to the FY 2020-21 Budget are necessary as shown in Exhibit A.
2. There are sufficient funds to fund the allocations.

NOW, THEREFORE, BE IT RESOLVED that the District Board of the Fort Bragg Municipal Improvement District No. 1 does hereby amend the previously adopted FY 2020-21 Budget to incorporate the changes enumerated in Exhibit A.

The above and foregoing Resolution was introduced by District Board Member _____, seconded by District Board Member _____, and passed and adopted at a regular meeting of the City Council of the City of Fort Bragg held on the 10th day of May 2021, by the following vote

AYES:
NOES:
ABSENT:
ABSTAIN:
RECUSED:

BERNIE NORVELL
Chair

ATTEST:

June Lemos, CMC
District Clerk

SHINCCI

ENERGY-EFFICIENT
LOW TEMPERATURE SLUDGE DRYING

ABOUT SHINCCI

A LEADER IN LOW TEMPERATURE SLUDGE DRYING

Shincci is a high-tech company devoting itself to the research and application in the field of environmental protection since 2003, who designs and provides the world's cutting-edge Low Temperature Sludge Drying Solution.

With its leading Low Temperature Evaporating-condensing-dehumidification Technology, Shincci creatively combines refrigerating system and thermal energy, making itself a pioneer in the industry. Starting with its first heat pump unit in 2004, Shincci has developed double-effect, triple-effect, quadruple-effect and multiple-effect dehumidification technologies thanks to its continuous innovation.

WE VALUE HIGH QUALITY

Shincci is committed to the upgrading of its production system, improves the collaborative capability of designing and manufacturing in the industrial chain, and has realized high quality standardized production.

WE PROVIDE CUSTOMIZED SOLUTIONS

Shincci has become a leading company with its customized solutions for on-site investigation, project designing, equipment manufacturing, installation, commissioning, and after-sales service.



OVERSEAS MARKETING

OVERSEAS FOOTPRINTS

To date, Shincci Sludge Drying Solutions have been successfully applied around the world such as USA, Italy, Poland, Romania, Russia, Turkey, South Korea, Thailand, Vietnam, Indonesia, etc. We are making every project a successful reference with the highest customer satisfaction.



APPLICATION & REUSE

With either electric power or waste-heat as heat source, the Shincci Sludge Dryer can simply reduce the moisture content of wet sludge from 83% to 30-10% (adjustable as required). It is energy-efficient and eco-friendly, and has been extensively applied in municipal and industrial sludge drying. And the dried sludge could be for resource utilization.



Municipal



Printing & Dyeing



Chemical



Pharmaceutical



Papermaking



Plating



Leather

SYSTEM FEATURES



EFFICIENCY

- Sludge moisture content can be reduced from 83% to 30-10% (adjustable as required)
- Sludge volume is reduced by 67% and weight by 80%



INNOVATION

- By originally developed "quadruple-effect dehumidification technology", the dehumidifying capacity reaches as high as 4.2 kg.H₂O/kWh, which is the world's leading technology standard
- Energy-consumption saved by 50% compared to the traditional drying equipment



ENVIRONMENT

- No odor emission during the process in a closed cabinet; No need for any expensive odor removal equipment
Available to be built inside the factory for sludge centralized processing
- The clear condensate water from the drying process can directly drain to sewage pool without any secondary treatment.



UTILIZATION

- No heat waste during the drying process in a closed loop system
- No need for high temperature heating like other open-type drying equipment



ECONOMICAL

- The running cost of drying wet sludge from 83% moisture to 30% is only 180 kWh/t



SAFETY

- Low processing temperature 40-75°C in a closed cabinet, no need for nitrogenization
Oxygen content < 12%, Dust concentration < 60g/m³, Dried sludge temperature < 70°C
- Outlet Sludge < 50°C, no need secondary cooling and can be stored directly



DURABILITY

- Adopting durable and anti-corrosive material to make sure a service life as long as 15 years
- Modularization design for easy assembly while saving floor space; Suitable for any working condition at high or low temperatures



STERILIZATION

- With pasteurization (low temperature heating sterilization) at 70°C drying for 90-120 minutes, it can sterilize over 90% bacteria effectively

LOW TEMPERATURE DRYING PRINCIPLE

The Low Temperature Sludge Dryer works by the principle of Dehumidification Heat Pump. This system makes the circulating hot air go through the wet sludge laid on the conveyor belt, which evaporates the moisture of the sludge. Since the whole system is proceeded in a closed loop, there is no waste of any heat during the process.

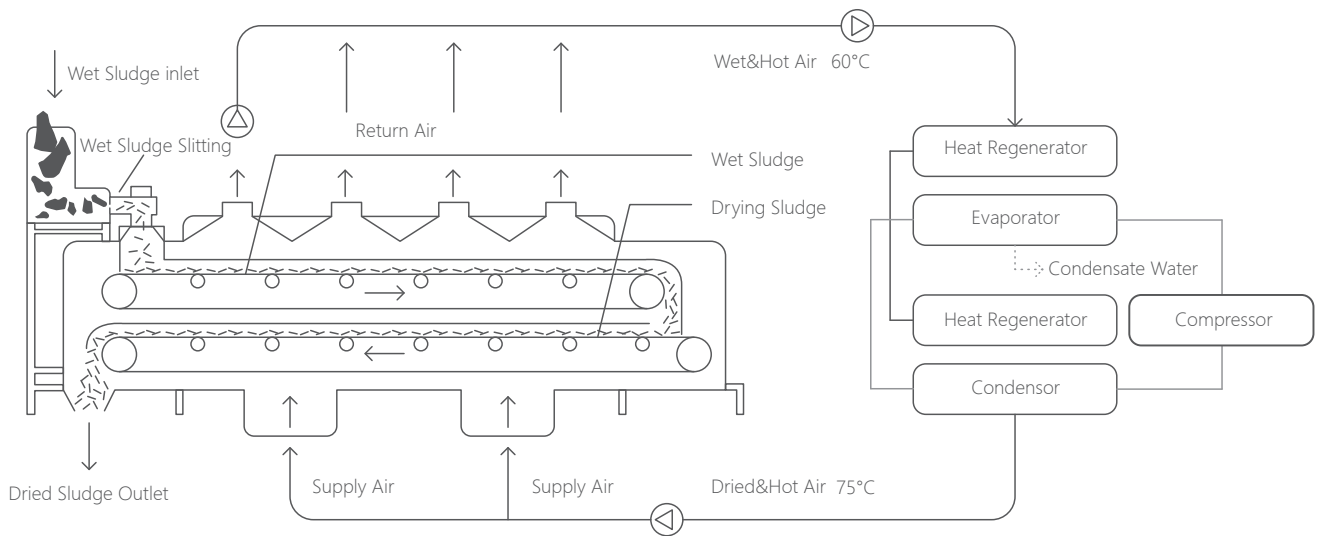

Waste-Heat-Exchanger Sludge Dryer makes use of waste heat source via hot water to remove the moisture out from sludge through hot air in the closed convectional recycling, condensing, dehumidifying and drying. Waste heat source can be low grade heat source, such as steam, hot water from anaerobic digestion gas, cooling water from generator set.

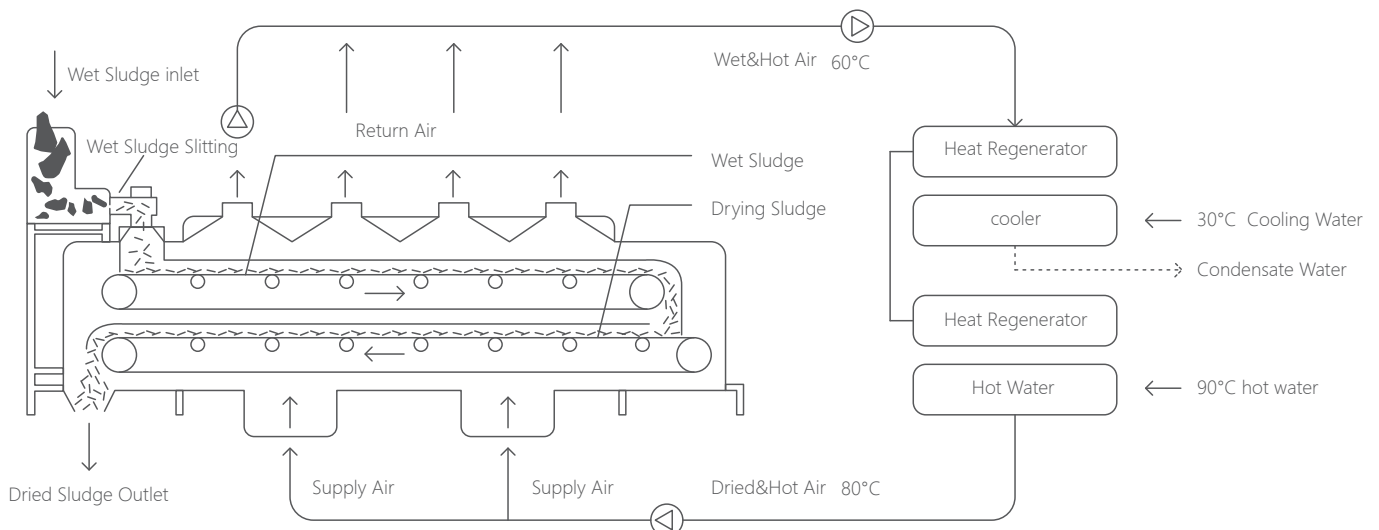

LOW TEMPERATURE BELT-TYPE SLUDGE DRYER

Innovative High-tech
Twice that of the current industry standard



FEATURES



EFFICIENCY



INNOVATION



ENVIRONMENT



UTILIZATION



ECONOMICAL



SAFETY

TECHNICAL PARAMETERS

Model	SBDD600SL	SBDD1200SL	SBDD2400FL	SBDD4800FL	SBDD7200FL	SBDD9600FL	SBDD14400SL
Standard Dehumidification Capacity/24h	600kg	1200kg	2400kg	4800kg	7200kg	9600kg	14400kg
Standard Dehumidification Capacity/h	25kg	50kg	100kg	200kg	300kg	400kg	600kg
Working Power	8kw	14kw	26kw	51kw	75kw	106kw	156kw
Dehumidification Heat Pump Module	1set	1set	1set	2set	3set	2set	3set
Compressor Amount	1set	1set	4set	8set	12set	8set	12set
Cooling Method	Water cooling SL		Forced-air cooling FL			Forced-air cooling FL	Water cooling SL
Flow of cooling water $\Delta t=15^{\circ}\text{C}$	0.2m ³ /h $\Delta t=20^{\circ}\text{C}$	0.4m ³ /h $\Delta t=20^{\circ}\text{C}$	//	//	//	//	9m ³ /h
Size(mm) (L*W*H)	2625*1277*1850	3170*1580*2080	3810*2215*2420	6800*2215*2420	9500*2215*2420	8150*3110*3200	11400*3110*3200
Structure	Whole set	Whole set	Whole set / Assembled set	Assembled set	Assembled set	Assembled set	Assembled set
Weight	1.5t	2.0t	3.2t	5.8t	8.0t	9.1t	12.3t

Model	SBDD19200SL	SBDD24000SL	SBDD28800SL	SBDD33600SL	SBDD38400SL	SBDD43200SL	SBDD48000SL
Standard Dehumidification Capacity/24h	19200kg	24000 kg	28800 kg	33600 kg	38400 kg	43200 kg	48000 kg
Standard Dehumidification Capacity/h	800kg	1000kg	1200kg	1400kg	1600kg	1800kg	2000kg
Working Power	208kw	260kw	312kw	364kw	416kw	468kw	520kw
Dehumidification Heat Pump Module	4set	5set	6set	7set	8set	9set	10set
Compressor Amount	16set	20set	24set	28set	32set	36set	40set
Cooling Method	Water cooling SL						
Flow of cooling water $\Delta t=15^{\circ}\text{C}$	12m ³ /h	15m ³ /h	18m ³ /h	21m ³ /h	24m ³ /h	27m ³ /h	30m ³ /h
Size(mm) (L*W*H)	14650*3110*3200	17900*3110*3200	21150*3110*3200	24400*3110*3200	27650*3110*3200	30900*3110*3200	34150*3110*3200
Structure	Assembled set	Assembled set	Assembled set	Assembled set	Assembled set	Assembled set	Assembled set
Weight	15.5t	17.7t	21.9t	25.1t	28.3t	31.5t	34.7t

» Appendix :

Refrigerant	R134a
Power Supply	(220V\380V\440V)/3H/50Hz(60Hz)
Drying Temperature	48 ~ 56°C(recycle air)/ 65 ~ 80°C(supply air)
Control System	Touch screen + PLC programmable control system
Applicable Range for Inlet Sludge	Water rate (40%-82%)(others is available for customization and testing)
Applicable Range for Outlet Sludge	Variable Frequency control to realize outlet range (10%-60%)
Shaping Method	Slitting (70%-83%)

TECHNICAL PARAMETERS (QUADRUPLE EFFECT)

Model	SBDD10800FSL	SBDD16200FSL	SBDD21600FSL	SBDD27000FSL	SBDD32400FSL	SBDD37800FSL	SBDD43200FSL	SBDD48600FSL	SBDD54000FSL
Standard Dehumidification Capacity/24h	10800kg	16200kg	21600kg	27000kg	32400kg	37800kg	43200kg	48600kg	54000kg
Standard Dehumidification Capacity/h	450kg	675kg	900kg	1125kg	1350kg	1575kg	1800kg	2025kg	2250kg
Working Power	105kw	155kw	205kw	255kw	305	355kw	405kw	455kw	505kw
Dehumidification Heat Pump Module	2set	3set	4set	5set	6set	7set	8set	9set	10set
Compressor Amount	8set	12set	16set	20set	24set	28set	32set	36set	40set
Cooling Method	Water cooling SL								
Flow of cooling water $\Delta t=15^{\circ}\text{C}$	8.5m ³ /h	12.8m ³ /h	17m ³ /h	21m ³ /h	25.5m ³ /h	30m ³ /h	34m ³ /h	38m ³ /h	42.5m ³ /h
Size(mm) (L*W*H)	8150*3110*3200	11400*3110*3200	14650*3110*3200	17900*3110*3200	21150*3110*3200	24400*3110*3200	27650*3110*3200	30900*3110*3200	34150*3110*3200
Structure	Assembled set	Assembled set	Assembled set	Assembled set	Assembled set	Assembled set	Assembled set	Assembled set	Assembled set
Weight	9.1t	12.3t	15.5t	17.7t	21.9t	25.1t	28.3t	31.5t	34.7t

» Appendix :

Refrigerant	R134a
Power Supply	(220V\380V\440V)/3H/50Hz(60Hz)
Drying Temperature	50 ~ 60°C(recycle air)/ 65 ~ 80°C(supply air)
Control System	Touch screen + PLC programmable control system
Applicable Range for Inlet Sludge	Water rate (75%-81%)(others is available for customization and testing)
Applicable Range for Outlet Sludge	Variable Frequency control to realize outlet range (10%-60%)
Shaping Method	Slitting (70%-83%)

LOW TEMPERATURE WASTE-HEAT SLUDGE DRYER

Waste-heat Utilization
Sludge Drying being More Economical



FEATURES



WASTE-HEAT SOURCE



EFFICIENCY



ENVIRONMENT



UTILIZATION



ECONOMICAL



SAFETY

TECHNICAL PARAMETERS

Model	SBWHD5000	SBWHD10000	SBWHD15000	SBWHD20000	SBWHD25000
Standard Dehumidification Capacity/24h	~ 5000kg	~ 10000kg	~ 15000kg	~ 20000kg	~ 25000kg
Standard Dehumidification Capacity/h	~ 208kg	~ 416kg	~ 624kg	~ 832kg	~ 1040kg
Working Power	13kw	26kw	39kw	52kw	65kw
Standard Heat - supplied power	200kw	400kw	600kw	800kw	1000kw
Hot water flow rate	8.6m ³ /h	17.2m ³ /h	25.8m ³ /h	34.4m ³ /h	43m ³ /h
Standard cooling power	180kw	360kw	540kw	720kw	900kw
Cooling water flow rate $\Delta t=12^{\circ}\text{C}$	13m ³ /h	26m ³ /h	39m ³ /h	52m ³ /h	65m ³ /h
Heat exchanger module quantity	1set	2set	3台	4set	5set
Size(mm) (L*W*H)	4900*3110*3200	8150*3110*3200	11400*3110*3200	14650*3110*3200	17900*3110*3200
Structure	Whole set	Assembled set	Assembled set	Assembled set	Assembled set
Weight	5.7t	8.6t	12.3t	14.8t	16.5t

Model	SBWHD30000	SBWHD35000	SBWHD40000	SBWHD45000	SBWHD50000
Standard Dehumidification Capacity/24h	~ 30000kg	~ 35000kg	~ 40000kg	~ 45000kg	~ 50000kg
Standard Dehumidification Capacity/h	~ 1248kg	~ 1458kg	~ 1667kg	~ 1875kg	~ 2083kg
Working Power	78kw	91kw	104kw	117kw	130kw
Standard Heat - supplied power	1200kw	1400kw	1600kw	1800kw	2000kw
Hot water flow rate	51.6m ³ /h	60.2m ³ /h	68.8m ³ /h	77.4m ³ /h	86m ³ /h
Standard cooling power	1080kw	1260kw	1440kw	1620kw	1800kw
Cooling water flow rate $\Delta t=12^{\circ}\text{C}$	78m ³ /h	91m ³ /h	104m ³ /h	117m ³ /h	130m ³ /h
Heat exchanger module quantity	6set	7set	8set	9set	10set
Size(mm) (L*W*H)	21500*3110*3200	24400*3110*3200	27650*3110*3200	30900*3110*3200	34150*3110*3200
Structure	Assembled set	Assembled set	Assembled set	Assembled set	Assembled set
Weight	20.4t	23.4t	26.3t	29.3t	32.2t

»Appendix:

Standard Heat - supplied conditions	90°C/70°C (hot water)
Cooling condition	33°C/45°C (condensate water)
Electric power source	(220V\380V\440V) /3H/50Hz (60Hz)
Standard drying temperature	50 ~ 65°C(recycle air)/ 68 ~ 85°C(supply air)
Heat power source	1. Flue gas waste heat ;2. Steam / Steam condensate water; 3. Anaerobic digestion ; 4. Sludge pyrolysis ; 5. Gen-set waste heat
Control System	Touch screen + PLC programmable control system
Applicable Range for Inlet Sludge	Water rate (40%-82%)(others is available for customization and testing)
Applicable Range for Outlet Sludge	Variable Frequency control to realize outlet range (10%-60%)
Shaping Method	Slitting (70%-83%)

LOW TEMPERATURE CONTAINER-TYPE SLUDGE DRYER

Movable Container-type
Feasible for small project with sludge from filter press



FEATURES



EFFICIENCY



MOVABLE



ENVIRONMENT

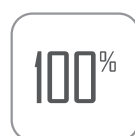

UTILIZATION



FLEXIBLE



SAFETY

FLWSHEET

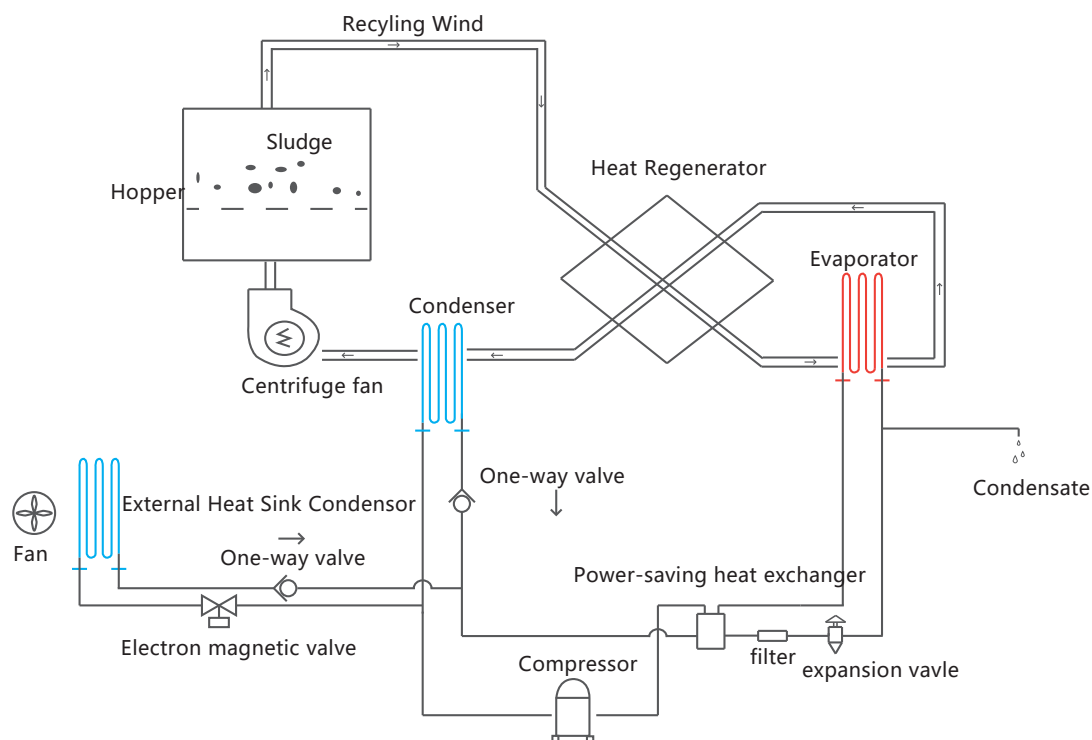

TECHNICAL PARAMETERS

Model	SCODD200FL	SCODD400FL	SCODD800FL
Standard Dehumidification Capacity/24h	200kg	400kg	800kg
Standard Dehumidification Capacity/h	8 ~ 13kg/h	15 ~ 23kg/h	30 ~ 46kg/h
Working Power	3.5kw	6.0kw	12kw
Hopper Size(mm)(L*W*H)	800 (L) *800 (W) *750mm (H)	1000 (L) *1000 (W) *900mm (H)	1200 (L) *1200 (W) *1100mm (H)
Size(mm) (L*W*H)	1650*1150*1500	2200*1350*1700	2600*1500*2000
Structure	Whole set	Whole set	Whole set
Weight	580kg	900kg	1430kg
Compressor Amount	1set		
Cooling Method	Forced-air cooling FL		

Model	SCODD1600SL	SCODD3200SL
Standard Dehumidification Capacity/24h	1600kg	3200kg
Standard Dehumidification Capacity/h	60~92kg/h	120 ~ 184kg/h
Working Power	24kw	48kw
Hopper Size(mm)(L*W*H)	1560 (L) *1560 (W) *1500mm (H)	1560 (L) *1560 (W) *1500mm (H)
Size(mm) (L*W*H)	3380*2150*2820	4000*3485*3200
Structure	Whole set	Whole set
Weight	2800kg	5000kg
Compressor Amount	1set	2set
Cooling Method	water cooling	

»Appendix:

Energy consumption	2.0 ~ 3.5kg.H2O/KW.h
Refrigerant	R134a
Power Supply	220V\380V\440V/3H/50Hz(60Hz)
Drying Temperature	40 ~ 50°C(recycle air)/60 ~ 80°C(supply air)
Control System	Touch screen + PLC programmable control system
Applicable Range for Outlet Sludge	10%-40%

PROJECT REFERENCES

With its mission of "Solving the sludge problem", Shincci is proud to play its part for the sustainable development of cities and industries in the globe, by which enabling itself to be an admirable brand.

For the past years, Shincci has achieved rapid development in Low Temperature Drying Technology, with hundreds of project references all over the world.

> Just review some of our customers and projects as below



中南市政设计院



华北设计院



上海市政设计院



西北市政设计院



西南设计院



北京排水集团
BEIJING DRAINAGE GROUP CO., LTD



北京首创股份



semcorp
胜科集团



中国节能



HITACHI
Inspire the Next
日立



MITSUBISHI
ELECTRIC



鲁抗
LUKANG
PHARMACEUTICAL



齐鲁制药
QILU PHARMACEUTICAL



LUXI
鲁西集团



RUNTU
润土



BEKAERT
better together



健康元
JoIncore



FOXCONN



京东方
BOE



BASF

FOSHAN JIALIDA EPC

SLUDGE TYPE	SLUDGE SCALE	DEWATERING TYPE	MOISTURE OF WET SLUDGE	MOISTURE OF DRIED SLUDGE
Textile	1000T/D	Screw Press	85%	30%



SHENZHEN, BINHE WWTP

SLUDGE TYPE	SLUDGE SCALE	DEWATERING TYPE	MOISTURE OF WET SLUDGE	MOISTURE OF DRIED SLUDGE
Municipal	250T/D	Screw Press	80%	50%



SHENZHEN, FUTIAN WWTP

SLUDGE TYPE	SLUDGE SCALE	DEWATERING TYPE	MOISTURE OF WET SLUDGE	MOISTURE OF DRIED SLUDGE
Municipal	250T/D	Filter Press	70%	40%



JIAOZUO JOINCARE BIOTECHNOLOGICAL

SLUDGE TYPE	SLUDGE SCALE	DEWATERING TYPE	MOISTURE OF WET SLUDGE	MOISTURE OF DRIED SLUDGE
Medicine residue	180 T/D	Screw Press	65%	30%



YUMA SEWAGE TREATMENT PLANT (USA)

SLUDGE TYPE	SLUDGE SCALE	DEWATERING TYPE	MOISTURE OF WET SLUDGE	MOISTURE OF DRIED SLUDGE
Municipal	6.5m ³ /d	Screw Press	98%	30%



NAPLES SCALEA WWTP (ITALY)

SLUDGE TYPE	SLUDGE SCALE	DEWATERING TYPE	MOISTURE OF WET SLUDGE	MOISTURE OF DRIED SLUDGE
Municipal	3T/D	Filter Press	75%	20%



POLAND PHARMACEUTICAL PLANT

SLUDGE TYPE	SLUDGE SCALE	DEWATERING TYPE	MOISTURE OF WET SLUDGE	MOISTURE OF DRIED SLUDGE
Pharmaceutical	5T/D	Filter Press	83%	30%



SIGHISOARA SEWAGE TREATMENT PLANT (ROMANIA)

SLUDGE TYPE	SLUDGE SCALE	DEWATERING TYPE	MOISTURE OF WET SLUDGE	MOISTURE OF DRIED SLUDGE
Municipal	20T/D	Screw Press	80%	10%



STATEMENT:

We reserve the right to alter the specifications in case of technological upgrading without prior notice.

VERSION: 201907001



GUANGZHOU SHINCCI ENERGY EQUIPMENT CO., LTD.

NO. 8 CAOTANG YILU, TAIHE TOWN, BAIYUN DISTRICT,
GUANGZHOU, CHINA

T +86 20 3732 0835-8000 **W** www.shincci.com

Budgetary Proposal

Project Name:
Fort Bragg, CA

Proposal Number:
460254

Equipment Type:
Solstice SRT 11

90% Product Dryness

Proposal Date:
8/26/2020

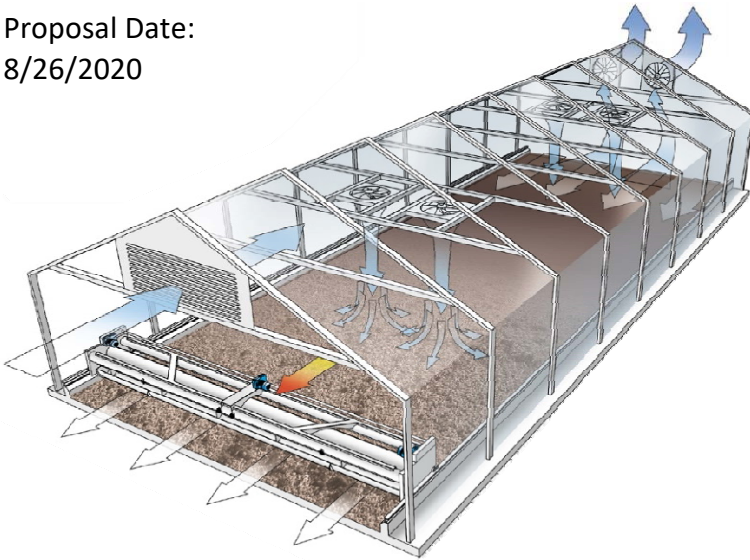

Huber Contacts:
John Lewis
Regional Sales Director - West
704-995-5451
John@hhusa.net

Represented by:
Ryan Spanton
Goble Sampson Associates
(801) 268-8790
rspanton@goblesampson.com

HUBER
TECHNOLOGY
WASTE WATER Solutions

Huber Technology, Inc.

**1009 Airlie Parkway
Denver, NC 28037**

Phone: (704) 949-1010

Fax: (704) 949-1020

Solstice Design Summary

Fort Bragg, CA

August 27, 2020

Sludge Characteristics:

Upstream Process: Activated Sludge with Secondary Clarifier
 Digestion Process: Aerobic Digester
 Sludge Type: Waste Activated Sludge
 Sludge VSS: Information not provided
 Sludge Protein Content: Information not provided

Project Design Parameters:

Sludge Feed Rate (given): 1,084 ton/yr
 Inlet Cake Concentration: 20%
 Calculated Sludge Loading Rate: 1,084 dry ton/yr (1,000 dry tonne/yr)
 5,421 wet ton/yr (2,700 wet tonne/yr)

	Temperature	Relative Humidity	Global radiation	Complete	External Input	Evaporation
January	48.8 °F	84.5%	0.19 kWh/ft ² /d	0.19 kWh/ft ² /d		0.005 ton/ft ²
February	49.1 °F	84.1%	0.26 kWh/ft ² /d	0.26 kWh/ft ² /d		0.007 ton/ft ²
March	49.9 °F	84.1%	0.39 kWh/ft ² /d	0.39 kWh/ft ² /d		0.011 ton/ft ²
April	51.3 °F	82.5%	0.52 kWh/ft ² /d	0.52 kWh/ft ² /d		0.014 ton/ft ²
May	54.5 °F	80.7%	0.63 kWh/ft ² /d	0.63 kWh/ft ² /d		0.018 ton/ft ²
June	58.1 °F	74.9%	0.68 kWh/ft ² /d	0.68 kWh/ft ² /d		0.020 ton/ft ²
July	61.6 °F	68.3%	0.66 kWh/ft ² /d	0.66 kWh/ft ² /d		0.021 ton/ft ²
August	62.0 °F	67.8%	0.58 kWh/ft ² /d	0.58 kWh/ft ² /d		0.019 ton/ft ²
September	61.3 °F	66.8%	0.48 kWh/ft ² /d	0.48 kWh/ft ² /d		0.016 ton/ft ²
October	57.5 °F	71.6%	0.35 kWh/ft ² /d	0.35 kWh/ft ² /d		0.012 ton/ft ²
November	52.4 °F	80.3%	0.22 kWh/ft ² /d	0.22 kWh/ft ² /d		0.007 ton/ft ²
December	48.9 °F	82.5%	0.17 kWh/ft ² /d	0.17 kWh/ft ² /d		0.005 ton/ft ²
Average			0.43 kWh/ft²/d			0.013 ton/ft²
Annually			156 kWh/ft²/a			

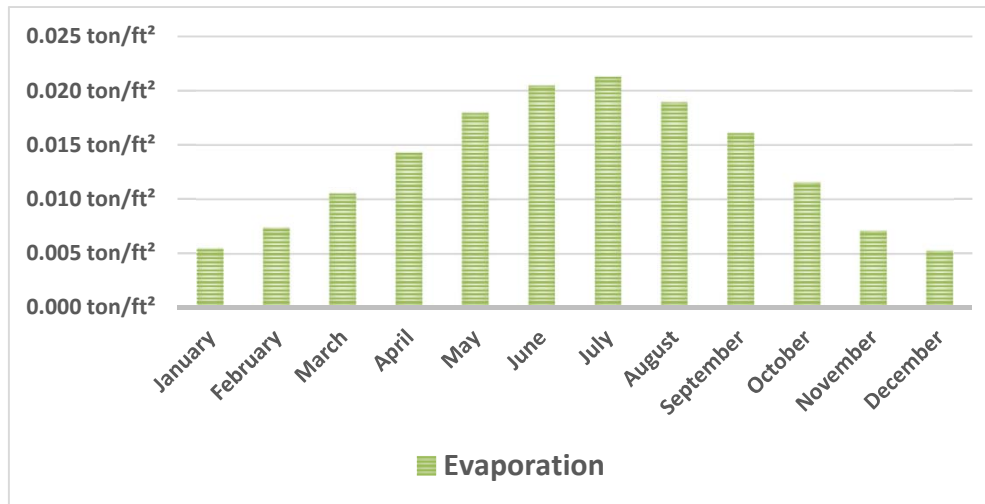
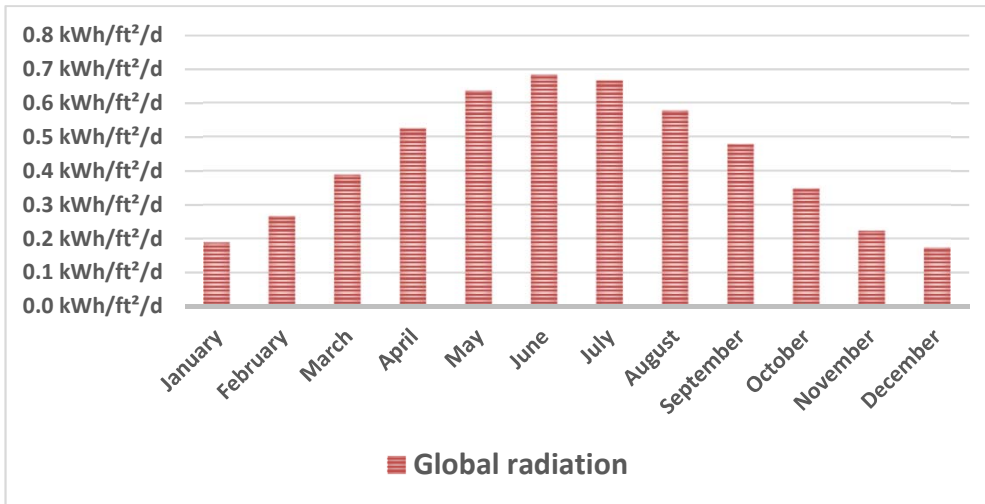
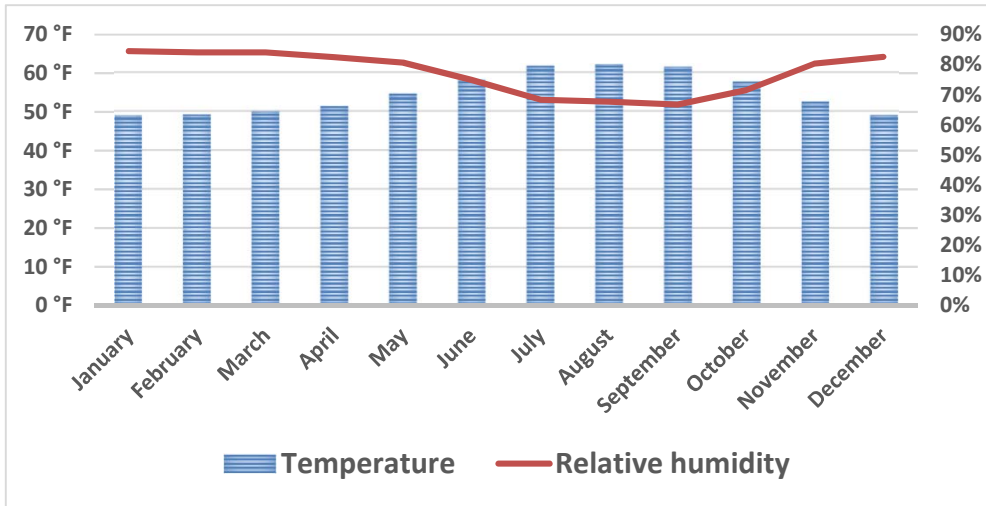

Equipment Recommendation:

Recommended unit model: Huber Dryer Solstice 11
 Recommended unit quantity: 3
 Recommended width of greenhouse: 118 ft (36 m)
 Recommended length of greenhouse: 354 ft (108 m)
 Length of drying field: 317 ft (97 m)
 Drying area (per unit): 11,438 ft² (1,063 m²)
 Total drying area (per greenhouse): 34,315 ft² (3,188 m²)

Project Design Calculations:

Estimated Dry Cake Solids Out: 90%
 Solids Loading Rate Out: 1,205 ton/yr
 Annual Water Evaporation Requirement: 4,216 ton water/yr

	Input	DSIn	Output	DSOut	Water evaporation	Sludge level
January	452 ton	20%	53 ton	90%	187 ton	10 in
February	452 ton	20%	72 ton	90%	252 ton	12 in
March	452 ton	20%	103 ton	90%	361 ton	12 in
April	452 ton	20%	140 ton	90%	489 ton	9 in
May	452 ton	20%	176 ton	90%	615 ton	4 in
June	452 ton	20%	139 ton	90%	487 ton	2 in
July	452 ton	20%	100 ton	90%	351 ton	2 in
August	452 ton	20%	100 ton	90%	351 ton	2 in
September	452 ton	20%	100 ton	90%	351 ton	2 in
October	452 ton	20%	100 ton	90%	351 ton	2 in
November	452 ton	20%	69 ton	90%	242 ton	4 in
December	452 ton	20%	51 ton	90%	179 ton	7 in
Sum/average	5421 ton	20%	1205 ton	90%	4216 ton	6 in

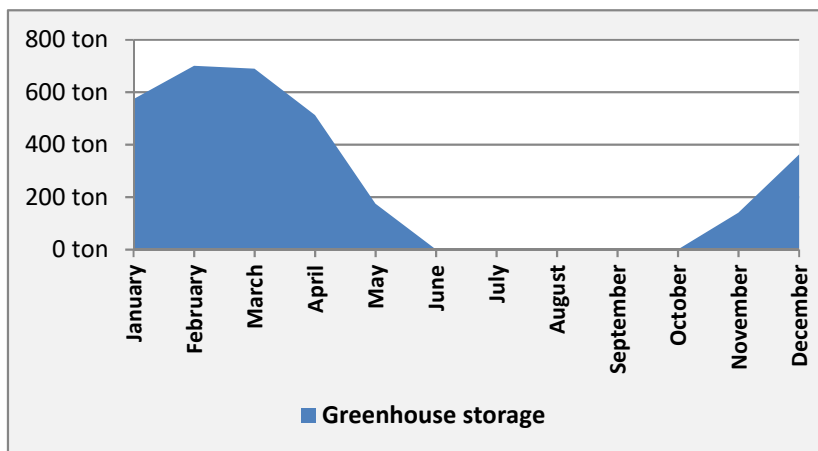

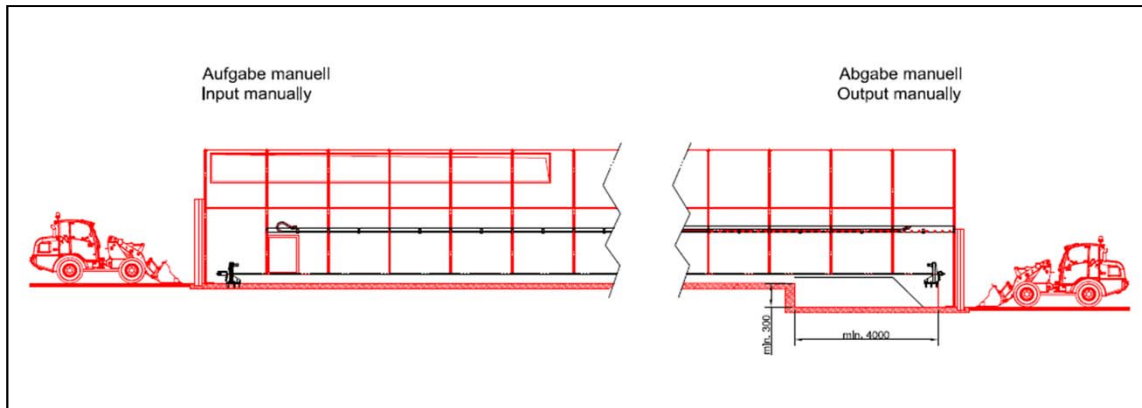
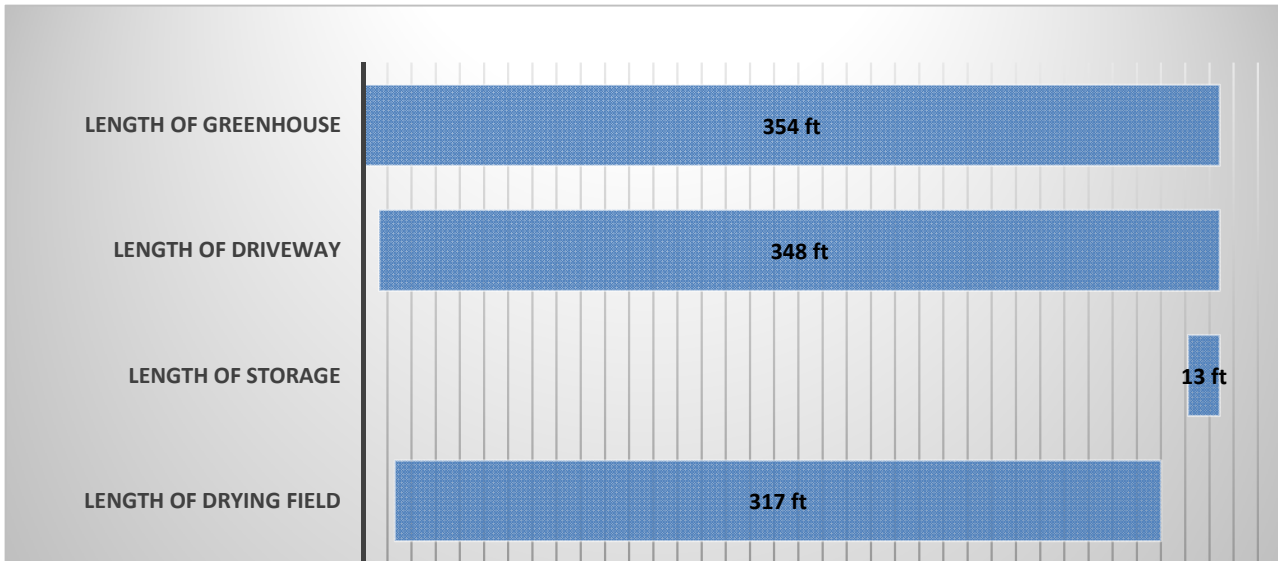

Electrical Consumption (Estimation):

	Numbers	Operation time	Effective power	Electrical consumption
Traction drive	3	2,292 h/a	2.20 kW	7,893 kWh
Sludge turning drives	3	1,146 h/a	5.50 kW	9,866 kWh
Lift drive shield	3	287 h/a	0.50 kW	43 kWh
Installation (estimation)	3	1,000 h/a	1.00 kW	3,000 kWh
Ventilators (all)	30	4,085 h/a	0.80 kW	98,040 kWh
SUM				118,843 kWh

Notes and Assumptions

Fort Bragg, CA

August 27, 2020

1. Equipment specification and drawings are available upon request.
2. If there are site-specific hydraulic constraints that must be applied, please consult the manufacturer's representative to ensure compatibility with the proposed system.
3. Huber Technology warrants all components of the system against faulty workmanship and materials for a period of 12 months from date of start-up or 18 months after shipment, whichever
4. Budget estimate is based on Huber Technology's standard Terms & Conditions and is quoted in US dollars unless otherwise stated.
5. Equipment recommendations are based on information provided to Huber Technology. Subsequent information which differs from what has been provided may alter the equipment
6. Pricing is based on Huber's standard control panel arrangement.
7. Greenhouse lengths may vary based on the required automation of the sludge input and discharge.
8. The offer is based on normal, homogenous municipal sludge with a minimum organic content of 45% and a maximum organic content of 70%. Sludge with organic content around 70% is assumed to have less than 45% protein value.
9. Feed sludge must be free of any pollutants which could be hazardous, toxic, radioactive, corrosive, flammable, or explosive.
10. Feed sludge must be free of lime which may have been added to stabilize or improve storage of the sludge. Sludge stabilized with lime can only be treated in drying plants which are specifically designed for this purpose.
11. Annual solids loading is based on 200,000 gal/wk at 2.5% feed solids to dewatering process with 100% capture rate.

Equipment Summary

Fort Bragg, CA

August 27, 2020

Dryer System:

Three (3) Huber SRT 11 Dryer, including:

- 304L stainless steel construction; pickled and passivated in acid bath
- Traction drive system and chain
 - 3HP, 460VAC, 3PH, 60Hz, VFD Motor
- Sludge turning unit
 - 10HP, 460VAC, 3PH, 60Hz, VFD Motor
- Galvanized steel rail system
- 21 Recirculation Fans
- 9 Exhaust Fans
- Dust Encapsulation
- Scraper Plate
 - 1.0HP, 460VAC, 3PH, 60Hz Motor

Control System - Solar Dryer, including:

- Solar Dryer Main Control Panel
- Solar Dryer Transfer Control Panel
- Junction Box

Greenhouse:

- Width and length to meet design criteria above
- Roof and side walls twin wall polycarbonate
- Galvanized steel frame
- Two (2) passage doors
- Two (2) overhead doors

Freight and Startup:

- Standard Huber Recommended Start-up Services
- Freight to jobsite.

Total Price: \$ 2,190,000 (for all units)

Dryer Options

Fort Bragg, CA

August 27, 2020

Optional Items which can be supplied by Huber (but are not included in the above pricing):

- Cake conveyance to the dryer
- Discharge and Dry Storage System
- Odor Control System

Items Not Supplied by Huber

Fort Bragg, CA

August 27, 2020

Items not included in the above offering:

- Wiring and piping between all supplied equipment
- Installation
- Concrete work
- Site Preparation
- Maintenance platforms and cranes

Sludge Treatment System Proposal

Project Entity	Fort Bragg
Project Description	Domestic Wastewater Sludge Drying
Project System	Low Temp Dehumidification Solids Treatment System
System Sludge Inlet	28,600 Gallons a day at 1.5% solids dewatered to 15% solids.
System Outlet Sludge	Approximately 2.3 Tons of dried solids per 24 hour day.
Project Designer	USA Sludge
Date	12/28/2020



Content

- [Background.....](#) 3
- [Dryer Overview](#) 4
- [Dryer Heat Pump Overview](#) 5
- [System Specifications.....](#) 6
- [Operating Cost/Unit Cost.....](#) 7
- [Pictures of Unit](#) 8-12
- [Installation.....](#) 13

USA Sludge is a High-Tech Enterprise devoted to dehumidification heat pump sludge drying.

This new line of dehumidification heat pump sludge dryers are the most advance sludge drying machines in the world.

USA Sludge has broken through the difficulties and the high costs associated with traditional gas drying equipment by implementation of a fin-type regenerative cycle with advance slitting, combined with double and triple effect heat pump cycling which dramatically lowers the cost of sludge drying by reusing the heat that would normally be discarded in a traditional sludge drying system.

This high-tech drying system has a small foot print, effectively treats many different kinds of sludge, requires no odor control equipment and doesn't require an fossil fuel emissions permit.



Dryer Overview

Below is a schematic of the USA Sludge Dryer. The dehumidification heat pump dries the wet sludge to dried Class A Fertilizer. The hot air and the condensate water are captured within the system.

There are no odor issues when using this closed cabinet drying system. The heat transferred from the compressor and fan motor is dissipated using a fan coil unit. The condensate water is captured and can be reused or recycled to the headworks of the treatment facility.

The dehumidification heat pump used in the proposed USA Sludge dryer utilizes the refrigeration principal to cool and dehumidify hot wet air. Through the heat pump principal, the heat pump recycles the latent heat released from steam congealing to water liquid. A dehumidification heat pump is equal to the dehumidification process (moisture removal or moisture dehumidifying) plus a heat pump process (energy recycling). A dehumidification heat pump can internally collect all the latent heat and sensible heat during air exhaust, bringing no waste heat to the outside.

The evaporation of sludge moisture absorbs latent heat; and the condensation of the generated vapor on the heat pump cycle releases latent heat. The evaporation process absorbs the same quantity of latent heat that the condensation process produces, according to the laws of thermodynamics and the law of conservation of energy. As a result, the drying process does not require additional heat capacity, resulting in the reduction of energy costs. The energy consumed during the process is only the electricity needed to operate the compressors and the air handlers.

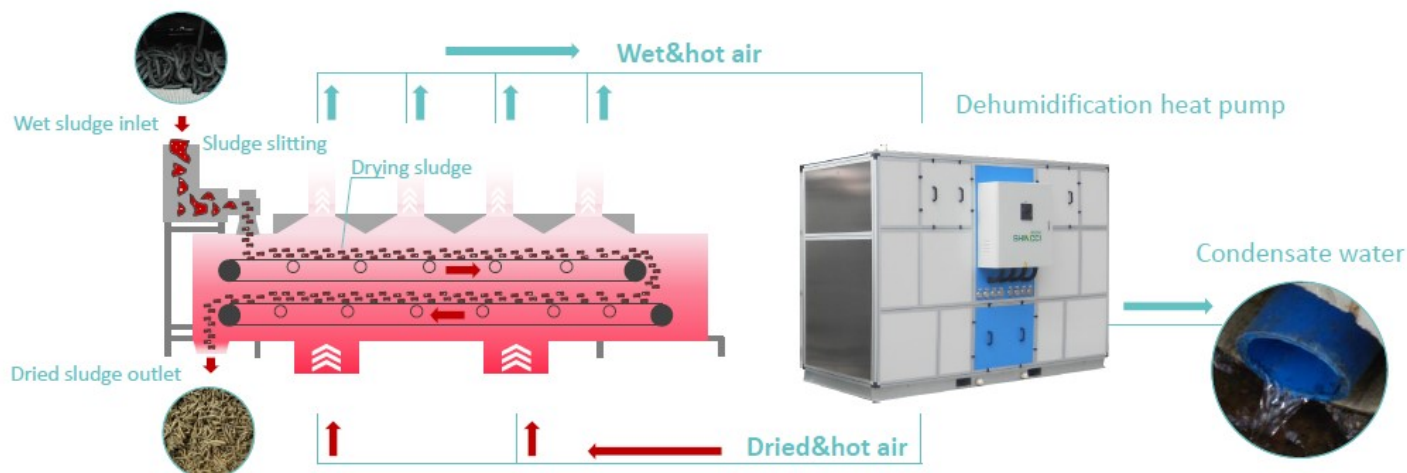

Material used in construction is anti-corrosive 304 stainless steel while the heat exchanger surface is specifically electroplated with an anti-corrosion material which extends the service life. The service life of the dryer is 20 years since there's no mechanical wear and tear during operation.

Triple effect and quadruple effect patented dehumidification technology can effectively maintain the air humidity lower than 10% which enables high drying efficiency and saves electrical consumption. The Independent layered blower system can satisfy the requirement of high-speed dehydration which shortens the period of low temperature drying. Modularized structure design enables high regulating capacity and easy installation. Conveyance motors and outlet conveyor have a frequency converter and infinitely variable speed enables regulated dried sludge moisture of between 10 and 50%

This heat pump system is designed to recycle the heat and reuse it in a closed cabinet dryer. One kilowatt hour is capable of drying 4 kg of H₂O. With a quadruple affect heat pump, electricity consumption of the dryer for 1 metric ton of sludge from 80% moisture to 10% moisture is 180 kilowatt hours . Electricity consumption of drying one metric ton of sludge from 80% moisture to 60% moisture is 118 kilowatt hours

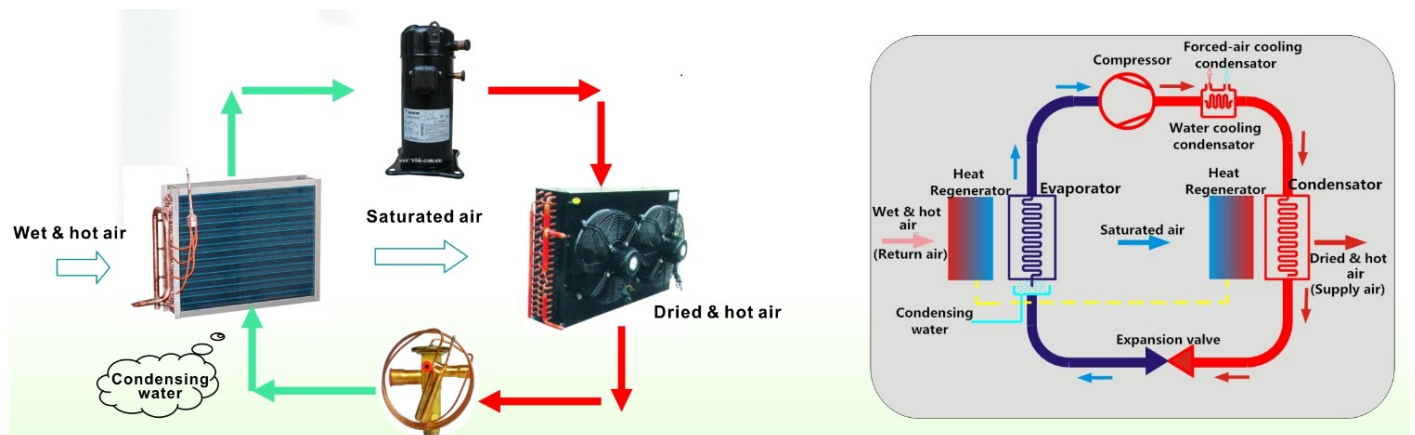

Product Specification

Model USA TSD 400E Sludge Drying System

Model	USA TSD 400E
Dehumidification Capacity Kg/Hr	400
Max Dehumidification Capacity T/24	9.6
Electric Consumed	104 kWh
Length	36feet (Required 46ft) Does Not included Conveyor
Width	8.5 feet (Required 20ft) Does Not include Conveyor
Height	9.1 feet (Required 16ft)
Weight (Full)	24,000 lbs.
Dehumidification Heat Pump Module	2 sets
Number of Compressors	16
Cooling Method	Forced Air
Refrigerant	R-134a
Power Supply	480 Volt 3PH 60Hz
Drying Temperature	118 - 132F (Recycle Air) / 148 - 176F (Supply Air)
Control System	Touch Screen + PLC Programmable Control System
Outlet Sludge	75% Solids

Operating Cost Heat Pump

Electrical consumption to dry to 75% solids

Energy consumption of low temperature heat pump drying system
(dry from 15% to 75% solids)

1. Per hour electricity consumption: 104 kWhs
2. Daily electricity consumption: 2496 kWhs

Water

System will condensate 105 gallons of water an hour or 2,520 Gallons a day.

Labor

The machine can operate unattended but pellet storage needs to be managed and the machine should be checked every hour. Filters need to be cleaned once a week and replaced every 90 days. Condensing coils need to be cleaned every 6 months and overall inspection once a year. Slitter combs need to be replaced once a year.

System Cost Heat Pump Dryer	\$499,800.
Inlet Conveyor 304 SS	\$40,000.
Total Project Cost	\$539,800.

Feed Hopper Inlet Conveyor

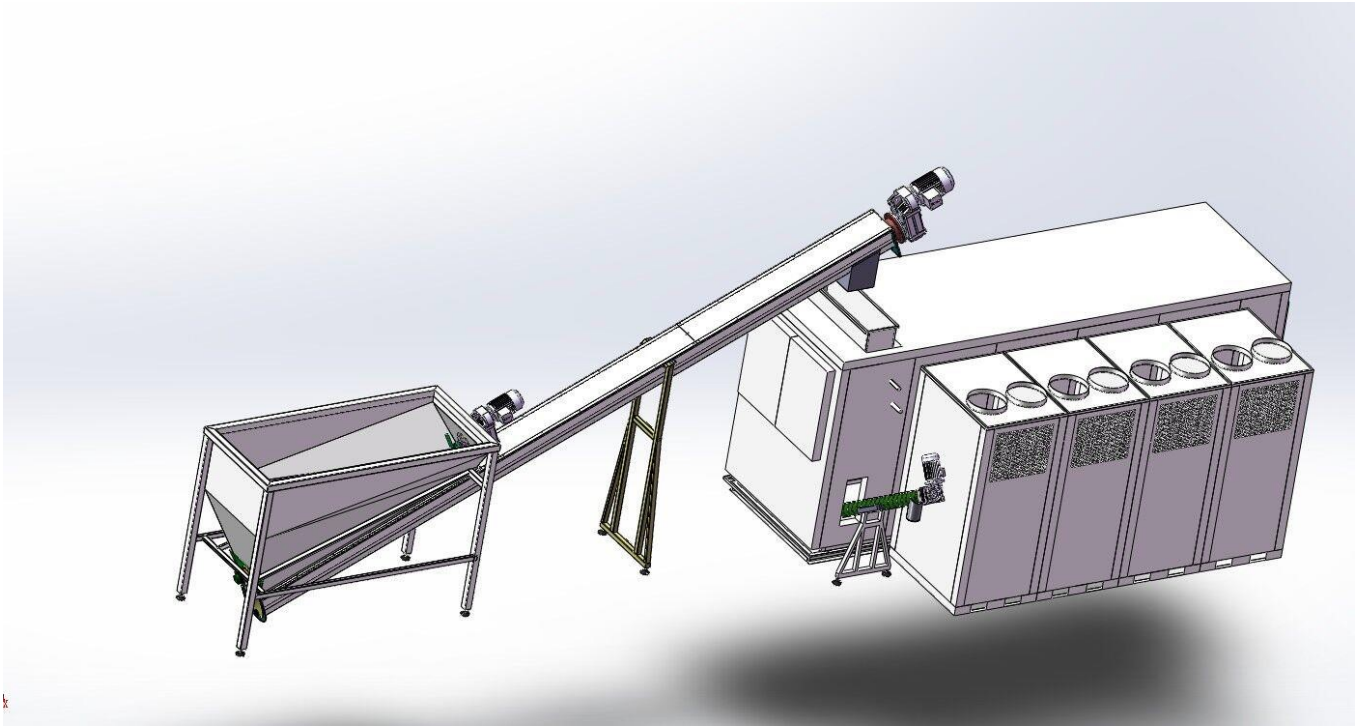

Belt Conveyor Pulled from Container



Second Forklift placed underneath Belt Conveyor



Truck drives away and Belt Conveyor transferred to forklift



Heat Pump Unit removed from Container



Belt Conveyor placed in Building





Compressors



Evaporators



Belt Section



Touch Screen



Sludge From Centrifuge

Sludge After Drying

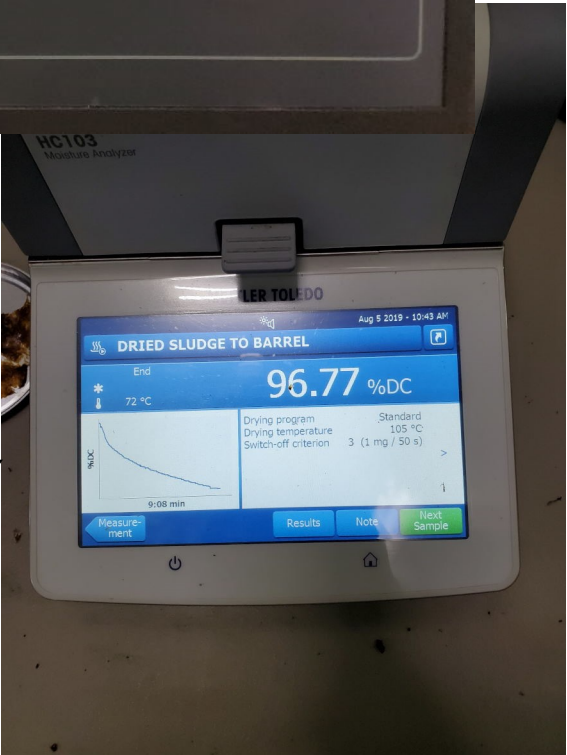



Delivery:

The unit will take 140 days from date of order to be delivered to your facility...Hopefully earlier.

Warranty:

5-year guarantee. USA Sludge Guarantee's Class A quality dried biosolids per the EPA 503 standards provided the sludge does not have "forever chemicals in the sludge.

Installation:

USA Sludge will have one engineer to help commission the unit. Commissioning will last no longer than 30 days. A Rigging company must be supplied to help install the unit.

Connections:

Plumbing connects 1" from the machine need to be completed by outside plumbing contractor.

Electrical connects to the machine need to be performed by outside electrical contractor.

A 200 Amp 480 3 Phase Disconnect.

A slab will need to be poured for the unit.

Date: December 10, 2020
To: Fort Bragg, CA WWTP
Proposal: ELODE Proposal No. FBCA-00010
Project: ELODE 2 Meter Unit, EODS-2000
Subject: ELODE Non-Thermal Sludge Dryer for Fort Bragg, CA WWTP

We are pleased to offer the following equipment and supply for your consideration relative to the above subject project.



ELODE USA, Inc. is located in Norwood, NJ (20 minutes outside of New York City) with our factory located in South Korea. ELODE has multi-installations throughout Asia and we are proud to introduce ELODE to US market with our proven track record. ELODE (Electro-Osmosis Dehydrator) is a Heat-less sludge dryer that dewater sludge cake using the lowest energy possible. Mechanisms of electro-osmosis and electrophoresis creates an ideal condition to apply 2nd stage dewatering process after your 1st stage dewatering press to further reduce water from your sludge cake. ELODE takes the sludge cake in between two electrically charged surfaces where it instantly starts to pull moisture away from the sludge, resulting in a moisture level far below any mechanical means.

Item #1

One (1) ELODE USA – 2 Meter ELODE Drying System. We are pleased to provide a preliminary budget estimate for electro-dewatering. Preliminary estimates are based on a sample testing conducted at ELODE USA, Norwood, NJ location on Nov. 24, 2020. Client supplied the sample via overnight carrier and test completed the following day.

The system includes the ELODE dewatering dryer, sludge leveling distribution system, cake entrance hopper, PLC based control panel (owner to specify control voltage/hertz).

Included: Some consumable parts [3 sets of filter belt, scraper, nozzles and 1 set of high pressure turbo nozzle hose] and Factory Limited Warranty, Commissioning of ELODE, (optional – central monitoring connection is an extra)

Preparation by Buyer:

- Foundation & Weather Enclosure
- Washer Water Supply
- Remove water and wash water drain system
- Vent Duct & Order Capture System
- Electrical Supply (180kw / unit, 3 phase, 240VAC or Higher)
- Compressed Air (low usage)
- Temperature Controlled Room for Control Unit
- Feed Pump or Conveyor to ELODE
- Conveyor to the dumpster from ELODE
- Unload Equipment & Move to site
- Hook up Power, Vent, Air, Control Panel and Plumbing

Item #2

The services of a factory trained representative for the purpose of installation supervision, inspection, startup, and operator training will be provided for a period not to exceed **five(5) days on-site, and to be completed in two (2) trips.**

Item #3

Final Information and Pricing for items listed above:

We propose to furnish the above described equipment for the Total Lot Net Selling Price of **\$763,000.00 USD**, to major US from shipping port – Busan, South Korea]. Customer is responsible for inland trucking & from receiving port and insurance.

Additional service may be requested at a rate of \$150 per hour, plus all travel and lodging expenses.

Please Note:

Except as otherwise noted herein, the following are not included in our offering:

Installation or off-loading, local, state or federal taxes, permits, or other fees, anchor bolts, local motor disconnects or lockouts, platforms, walkways, handrails or any structural and/or safety materials.

Warranty:

Our equipment shall be warranted against defects in workmanship and materials for a period of **eighteen (18)** months after delivery or **twelve (12)** months after start-up, whichever comes first. This warranty is based upon compliance with ELODE USA's handling, storage, installation, startup, operating and maintenance procedures.

Unless otherwise specified our standard payment terms are as follows;
Terms & Conditions:

- Payment schedule is as follows:
 - 25% with the purchase order
 - 35% after submittal of shop drawings
 - 35% upon equipment inspection at the factory (S. Korea)
 - 5% upon delivery of equipment and O&M manuals & commissioning. [Max. 4 weeks after delivery]

Early shipments and partial shipments will be invoiced as shipped on a prorated basis to be determined by ELODE USA.

Unless otherwise specified this proposal is offered for acceptance for (90) ninety days and is subject to review thereafter. Pricing is firm based upon receipt of a Purchase Order within this (90) ninety-day period. Delays in shipments caused by slow return of submittals or other delays caused by the contractor, owner, owner's agents or engineer may result in additional charge of 1% per month.

Submittal Schedule:

Approval submittals can be forwarded approximately **6-10 weeks** after our receipt and acceptance of your purchase order.

Delivery Schedule:

Shipment of equipment can be made approximately **20-24 weeks** after our receipt of approval and your release to manufacture.

These lead times are based upon typical Engineering and Shop loading, which may vary to some degree.

Offering Basis:

Please note that our offering, as described herein, is based upon ELODE standard model. Should the contents of any addenda (or other applicable documents) have an effect on our offering, we must reserve the right to modify that offering (and pricing/terms) accordingly. We request your assistance in keeping us abreast of all changes to the contract documents.

We wish you a success on this project and look forward to the opportunity of working with you.

Sincerely,

SIGN: _____

Hahn Min
President
ELODE USA, Inc.

May 3, 2021

City of Fort Bragg
416 N Franklin
Fort Bragg, CA 95437

ATTN : Alden Ramos

Dear Alden,

Below is your 2021 pricing for Sod Hypo 12.5% and SBS 25%.

Tank Type	Product	Tank Size	Price per Gallon	Contract Expires
Vertical Tank	Sodium Hypochlorite 12.5%	4000	\$1.40	4/12/22
Vertical Tank	Sodium Bisulfite 25%	3500	\$1.53	4/12/22

UNIVAR is the largest distributor of inorganic acids and bases in the Western United States. Because we specialize in these products, we have developed our capabilities to provide the specific safety, delivery, and quality services required by our customers. The following is a brief overview of some of these value-added services:

- **UNIVAR uses** company owned & maintained radio dispatched trucks. These trucks are equipped with permanently mounted, strong-tight storage tanks and low-pressure air diaphragm pumps for safety.
- **UNIVAR has** 24-hour emergency and weekend service available for our customers.
- **UNIVAR offers** safety seminars and training for our customers on the proper storage & handling of our products. In addition, we offer technical, environmental and regulatory assistance as needed.
- **UNIVAR has** liability insurance in excess of one million dollars.
- **UNIVAR offers** permanent and temporary tank & containment installations. In the event of an emergency with a customer's tank (or for routine maintenance), we have the capability of pumping product out of a tank to facilitate repairs/maintenance.

I appreciate your trust in UNIVAR as your chemical supplier. I will continue to stay in contact with you regarding our proposal. Again, should you have any questions please do not hesitate to contact me at 559-901-5129.

Sincerely,

Jeff Crenshaw

Jeff Crenshaw
Sales Account Manager, Mini-Bulk
Univar USA

All transactions are subject to Univar's Standard Terms & Conditions, available at <https://www.univarsolutions.com/sales-terms/> or upon request. Univar rejects all other terms and conditions unless otherwise agreed upon in writing by an authorized Univar representative. "This message and any attachment are privileged and confidential. If you are not the intended recipient, please telephone or email the sender and delete the message and any attachment from your system. If you are not the intended recipient you may not copy this message or attachment or disclose the contents to any other person."



City of Fort Bragg

416 N Franklin Street
Fort Bragg, CA 95437
Phone: (707) 961-2823
Fax: (707) 961-2802

Text File

File Number: 21-225

Agenda Date: 5/10/2021

Version: 1

Status: Business

In Control: City Council

File Type: Resolution

Agenda Number: 8D.

Receive Report and Consider Adoption of City Council Resolution Recommending and Encouraging Voluntary Implementation of Stage 1 Water Conservation Measures in Fort Bragg



AGENCY: City Council
MEETING DATE: May 10, 2021
DEPARTMENT: City Manager/Public Works
PRESENTED BY: T. Miller/J. Smith
EMAIL ADDRESS: tmiller@fortbragg.com
jsmith@fortbragg.com

AGENDA ITEM SUMMARY

TITLE:

Receive Report and Consider Adoption of City Council Resolution Recommending and Encouraging Voluntary Implementation of Stage 1 Water Conservation Measures in Fort Bragg

ISSUE:

The City of Fort Bragg Municipal Code Chapter 14.06, Water Conservation, sets forth the parameters for the City to declare a water emergency and implement mandatory water conservation consistent with the Stage or level of the emergency. However, staff has determined that the parameters as set forth in the Code occur too late in a water shortage for water conservation to be truly effective in managing a water emergency. Action is necessary before the City crosses those thresholds and not after.

The City has not met any of the thresholds to declare a water emergency and implement water conservation measures but staff feels it prudent to ask our water customers to target a Stage 1 conservation goal to reduce normal water usage by 10% for this time of year.

ANALYSIS:

Fort Bragg Municipal Code Chapter 14.06, Water Conservation, section 14.06.020 was most recently updated on January 25, 2016 and sets forth the three independent triggers that measure the City's ability to replenish water storage. The City has not currently met any one of those requirements.

However, Governor Newsom [declared a state of emergency](#) for Mendocino and Sonoma County due to drought conditions on April 21, 2021. That followed the declaration by USDA on March 5, 2021, that 50 counties in California were designated as primary natural disaster areas due to recent drought, including Mendocino County. Current flows in the Noyo River are now trending lower than any drought year on record, including 1977 (see Attachment 2). City staff is already preparing for drought conditions this summer by working with CalOES to procure additional water resources, including portable desalinization equipment.

The City of Fort Bragg's water supply system relies solely on three surface water sources: Waterfall Gulch (tributary to Hare Creek), Newman Gulch (tributary to Noyo River), and the Noyo River (diversion is at Madsen Hole). In 2015, the City's water supply system could only store small amounts of water that provided enough to maintain proper water system pressure and to provide a safety margin for fire-fighting flows. Five years later, the City has made great progress with water storage by including an additional 1.5 million gallon finished water storage tank and the Summers Lane Reservoir with a raw water capacity of 14.7 million gallons. This brings our total water storage capacity to 22.6 million gallons.

AGENDA ITEM NO. 8D

During the winter and spring, pumping of the Noyo River is used only to supplement the Waterfall Gulch and Newman Gulch sources. The two tributary sources generally provide a higher quality of raw water and they gravity-feed to the water treatment plant, whereas water from the City's Noyo River diversion must be pumped. As summer progresses and the flows in the tributary streams diminish, the Noyo River diversion is used more frequently and in greater quantities.

By making small reductions in our water usage today, we may avoid a higher level Water Emergency later. Under the current Municipal Code, the City cannot mandate a Stage 1 level of water conservation without meeting one of the three thresholds in section 14.06.020 or after conducting a public hearing with proper notice and making appropriate findings of necessity (California Water Code 375).

RECOMMENDED ACTION:

Adopt Resolution recommending and encouraging voluntary implementation of Stage 1 water conservation measures which target a 10% decrease in water usage from the same time in the base year.

ALTERNATIVE ACTION(S):

1. Do not adopt the Resolution.
2. Provide alternative direction to staff.

FISCAL IMPACT:

Reduced water usage will impact Water Fund revenues during the time frame customers practice water conservation, however, the water fund's reserves and fund balance can absorb the loss. A small reduction now may mitigate the necessity of more significant mandatory water conservation measures in the future that would have a greater impact on revenue.

GREENHOUSE GAS EMISSIONS IMPACT:

Reduced water usage will have an incremental reduction in pumping and water treatment, which will result in a small decrease in the use of electricity and resulting greenhouse gas emissions.

CONSISTENCY:

N/A

IMPLEMENTATION/TIMEFRAMES:

The request for voluntary compliance with Stage 1 water conservation measures would be immediate and if implemented water usage could be reduced immediately.

ATTACHMENTS:

1. Resolution
2. Noyo River Flows Graph

NOTIFICATION:

N/A.

RESOLUTION NO. ____-2021

**RESOLUTION OF THE FORT BRAGG CITY COUNCIL
RECOMMENDING AND ENCOURAGING VOLUNTARY IMPLEMENTATION
OF STAGE 1 WATER CONSERVATION MEASURES**

WHEREAS, the City of Fort Bragg has experienced significantly less rainfall over the past two years placing the City in an extreme drought condition; and

WHEREAS, the water flows from the City's three raw water sources continue on a downward trend; and

WHEREAS, the Noyo River flow is nearing 10.0 cubic feet per second (csf) and continues to decline at a rate of 0.5 cfs per day; and

WHEREAS, the high tides during periods of low flow levels on the Noyo River increases salinity content impairing the City's ability to replenish water supply from the Noyo River; and

WHEREAS, the weather forecasts continue to show no significant rainfall in the area in the coming weeks; and

WHEREAS, on April 21, 2021, Governor Newsom declared a state of emergency in Mendocino County due to drought conditions; and

WHEREAS, on March 5, 2021, the USDA declared that 50 counties in California, including Mendocino County were designated as a primary natural disasters area due to recent drought; and

WHEREAS, the City's water supply and ability to replenish its supply have not dropped to the levels established in the Fort Bragg Municipal Code section 14.06.020 which would require that the City declare a water emergency. However, implementing conservation measures now will reduce future impacts on the City's water supply and water storage levels and potentially avoid a greater level of water emergency; and

WHEREAS, based on all the evidence presented, the City Council finds as follows:

1. It is in the best interests of the City of Fort Bragg to encourage voluntary compliance with Stage 1 water conservation measures.
2. Waiting to implement water conservation measures until the established triggers set forth in Fort Bragg Municipal Code section 14.06.020 may be too late to avoid or reduce future water shortages.

NOW, THEREFORE, BE IT RESOLVED that the City Council of the City of Fort Bragg does hereby recommend and encourage voluntary implementation of water conservation measures consistent with a Stage 1 Water Emergency (Fort Bragg Municipal Code section 14.06.050 A) with a goal of reducing citywide water usage by 10%, as outlined below:

1. All users of potable water are strongly encouraged to reduce their potable water consumption by 10% as compared to the same month of the base year.
2. Consistent with state requirements to prevent the waste and unreasonable use of potable water and to promote water conservation, each of the following actions is strongly discouraged:

- a. The use of potable water on outdoor landscapes in a manner that causes runoff such that water flows onto adjacent property, nonirrigated areas, private and public walkways, roadways, parking lots, or structures.
 - b. The use of a hose that dispenses potable water to wash a motor vehicle, or to irrigate landscaped areas, including trees and shrubs located on residential and commercial properties that are not irrigated by a landscape irrigation system, except where the hose is fitted with a shut-off nozzle or device attached to it that causes it to cease dispensing water immediately when not in use.
 - c. The use of potable water to wash driveways, sidewalks, and similar hardscapes.
 - d. The use of potable water in a fountain or other decorative water feature, except where the water is part of a recirculating system.
 - e. The irrigation of outdoor landscapes during and within 48 hours after measurable rainfall.
 - f. The irrigation of residential and commercial landscapes, at any time other than before 10:00 a.m. and after 6:00 p.m.
 - g. The serving of drinking water other than upon request in eating or drinking establishments, including but not limited to restaurants, hotels, cafes, cafeterias, bars, or other public places where food or drink are served and/or purchased.
 - h. The irrigation with potable water of ornamental turf on public street medians.
 - i. The irrigation with potable water of landscapes outside of newly constructed homes and buildings in a manner inconsistent with regulations or other requirements established by the California Building Standards Commission and the Department of Housing and Community Development.
3. In addition, each of the following uses of potable water is strongly discouraged:
- a. The use of any hose or similar device, irrespective of whether a nozzle, valve, or other shut-off mechanism is attached thereto, for washing or cleaning the exterior surface of any dwelling, garage, commercial or industrial building. Persons painting building exteriors shall be exempted from this provision when potable water is used to clean or prepare a surface for painting.
 - b. The use of potable water for filling or refilling any existing or new swimming pool. Replenishing existing pools which have lost water due to evaporation shall be permitted.
 - c. The use of potable water in construction projects for backfill consolidation or compaction, or for dust control purposes; provided, however, that the City Manager may permit the use of potable water upon a determination by the City Manager that no other source of water for the purpose is available, or that no other method of

compaction, consolidation, or dust control is reasonably available. The reuse of water system flush water is permitted.

d. The use of water through, with or by any plumbing, sprinkler, watering or irrigation system, or other device, equipment, or appliance which is broken or defective, or which, for any reason, fails to use water in the ordinary and customary manner or quantity for which it was designed, constructed, or manufactured.

4. To promote water conservation, operators of hotels and motels should provide guests with the option of choosing not to have towels and linens laundered daily. Each hotel or motel shall prominently display notice of this option in each guestroom using clear and easily understood language.

5. To prevent waste and unreasonable use of potable water and to promote water conservation, lawn watering and landscape irrigation with potable water should be limited to no more than 2 days per week for all water users.

6. Residents and business owners should repair all water leaks as soon as feasibly possible, but no later than 5 days after notification by the City, unless other arrangements are made with the Public Works Director.

The above and foregoing Resolution was introduced by Councilmember _____, seconded by Councilmember _____, and passed and adopted at a regular meeting of the City Council of the City of Fort Bragg held on the 10th day of May, 2021, by the following vote:

**AYES:
NOES:
ABSENT:
ABSTAIN:
RECUSED:**

BERNIE NORVELL
Mayor

ATTEST:

June Lemos, CMC City Clerk

Noyo Flows

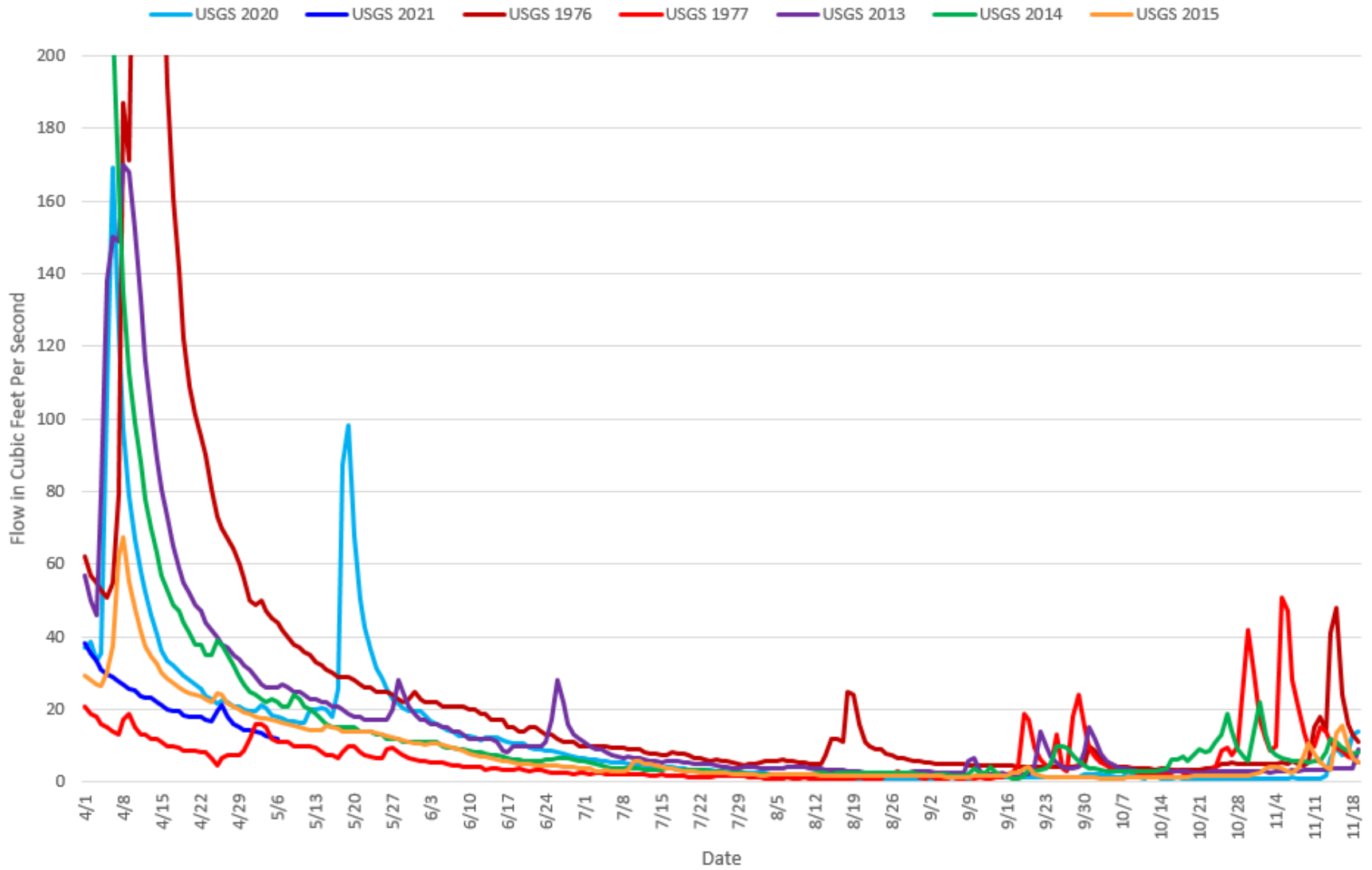

Noyo Flows

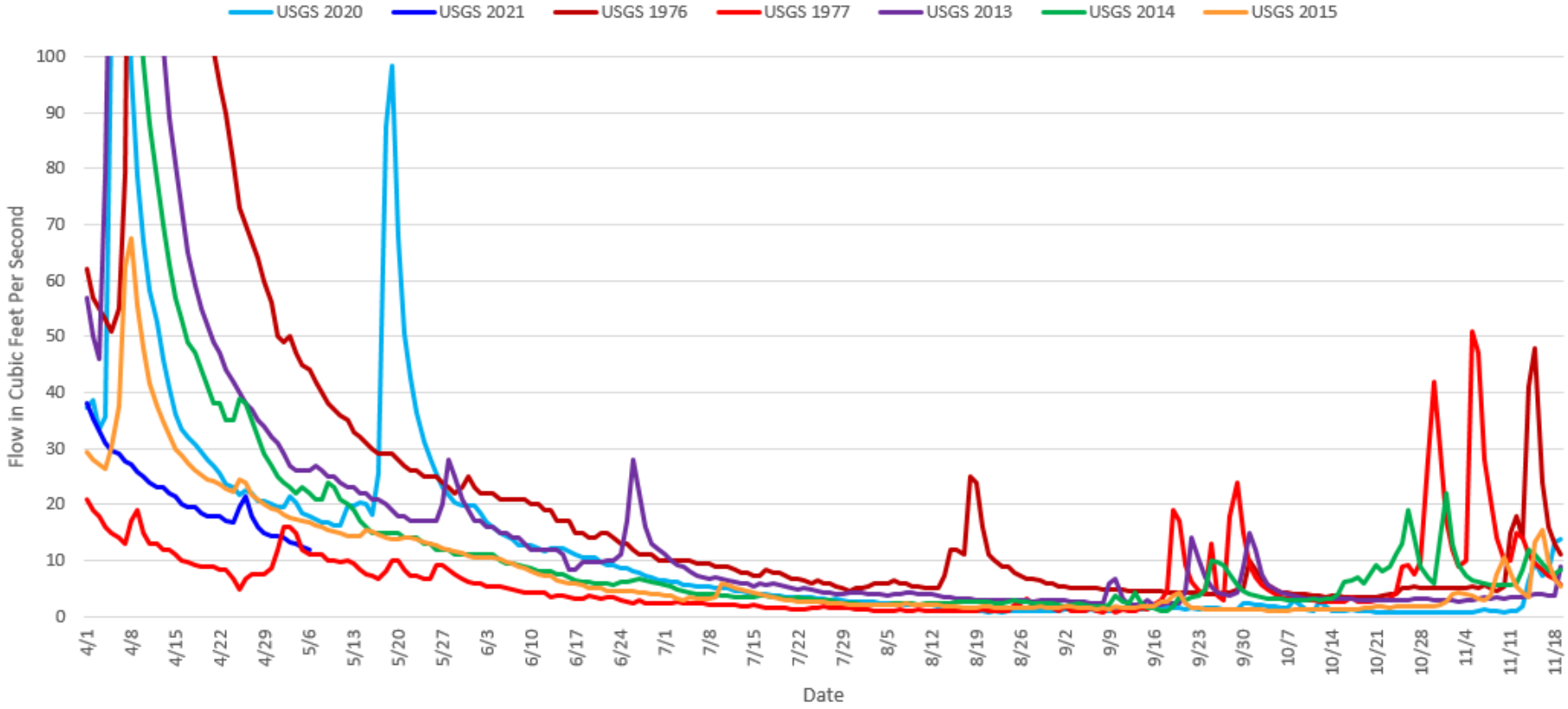

Noyo Flows

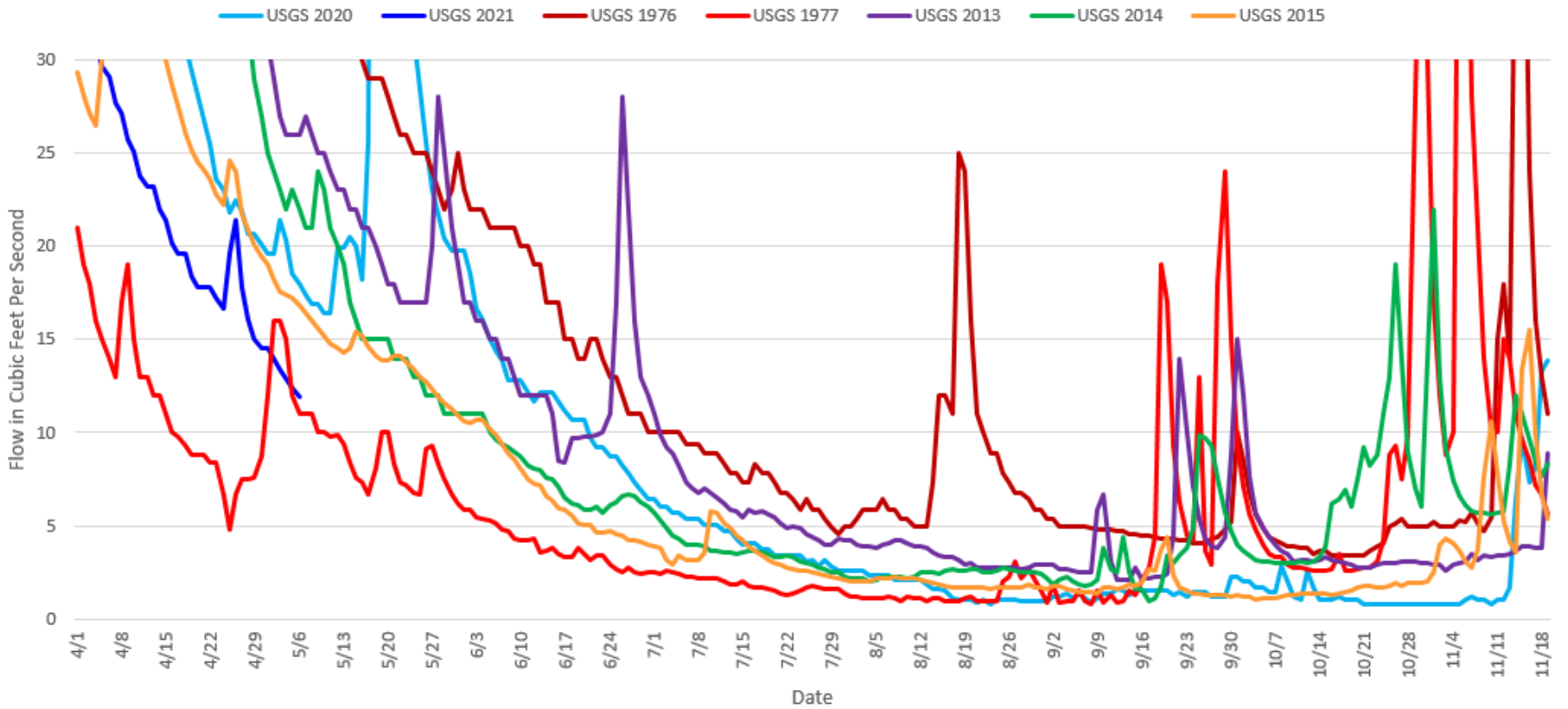

Lemos, June

From: Megan Caron <megancaron27@gmail.com>
Sent: Monday, May 10, 2021 7:44 PM
To: Lemos, June
Subject: Item 8 D Drought, Water emergency

Greetings Councilmembers,

Since we are at historically low water levels perhaps we need to have the lodging industry be more conservative with water consumption, how can we have them implement water conservation efforts with their guests? Lodging establishments should have water storage tanks for the summer months. It's kind of frightening to think that we could run out of water this summer and here we are washing linens all day long that have been used once by a visitor.

Megan Caron
Fort Bragg

Sent from my iPhone



City of Fort Bragg

416 N Franklin Street
Fort Bragg, CA 95437
Phone: (707) 961-2823
Fax: (707) 961-2802

Text File

File Number: 21-222

Agenda Date: 5/10/2021

Version: 1

Status: Business

In Control: City Council

File Type: Staff Report

Agenda Number: 8E.

City Council Report on Actions Following Adoption of Interim Urgency Ordinance Placing a 45-day Moratorium on the Approval of Applications and Permits for Formula Businesses in the Inland Zoning Area



AGENCY: City Council
MEETING DATE: May 10, 2021
DEPARTMENT: City Manager
PRESENTED BY: Tabatha Miller
EMAIL ADDRESS: tmiller@fortbragg.com

AGENDA ITEM SUMMARY

TITLE:

City Council Report on Actions Following Adoption of Interim Urgency Ordinance Placing a 45-day Moratorium on the Approval of Applications and Permits for Formula Businesses in the Inland Zoning Area

ISSUE:

The City Council discussed regulating formula businesses on October 24, 2019 and February 24, 2020. After the second discussion, the City Council directed staff to bring the matter to the Planning Commission to draft an ordinance that would apply to the Inland area of the City and bring back to City Council. After delays related to the COVID-19 pandemic, staffing reductions and staff turnover in the Community Development Department, the Planning Commission began working on developing a complete Ordinance in October 2020 and has continued its work.

Under [California Government Code Section 65858](#), a city or county may adopt an interim ordinance to temporarily prohibit certain land uses that may be in conflict with a contemplated general plan, specific plan or zoning proposal that the City Council and/or Planning Commission is considering or studying. The temporary prohibition or moratorium provides municipalities time to study the impact of certain activities and develop appropriate regulations, if deemed necessary.

On April 12, 2021, the City Council adopted Urgency Ordinance No. 964-2021, placing a 45-day moratorium on the approval of applications and permits for formula businesses in the Inland Zoning Area. Urgency Ordinances require four of five Councilmembers to approve and also to extend. On the same day, an Urgency Ordinance for a formula business moratorium in the Coastal Zoning Area failed.

Ten days prior to the expiration of the urgency ordinance or any extension, City Council must issue a written report describing the measures taken to alleviate the condition that led to the adoption. The City's current Moratorium will expire on May 27, 2021. Government Code Section 65858(d) provides:

(d) Ten days prior to the expiration of that interim ordinance or any extension, the legislative body shall issue a written report describing the measures taken to alleviate the condition which led to the adoption of the ordinance.

The attached report from the Fort Bragg Mayor and City Council meets the requirement of Government Code 65858(d).

After notice and a hearing, a local government can extend the ordinance for either ten months and 15 days, with the option to extend it once more for an additional one year, or once for 22 months and 15 days. Either option equates to an extension of up to two years and requires the four-fifths vote. The legislative body may rescind the urgency ordinance prior to its stated termination.

On May 24, 2021, staff will present the City Council with a new urgency ordinance to extend the moratorium for a period of ten months and fifteen days, as provided for in Government Code Section 65858. If adopted, staff anticipates that it will take far less than the 10 months and 15 days, as provided for in Government Code 65858, for the City Council to consider and possibly adopt an ordinance regulating formula businesses. City Council may terminate a moratorium prior to its stated expiration date and staff recommends such action after a formula business ordinance becomes effective or City Council decides not to pursue such regulation.

RECOMMENDED ACTION(S):

1. Present the City Council’s report to members of the public pursuant to Government Code 65858(d).

FISCAL IMPACT:

The impact of the moratorium on formula businesses to the City’s revenue is likely minimal.

GREENHOUSE GAS EMISSIONS IMPACT:

N/A

CONSISTENCY:

The City’s current Inland General Plan provides support for regulating formula businesses. The current purpose statement from Element 6 of the Inland General Plan:

A. Purpose

The Community Design Element establishes goals, policies, and programs to preserve and enhance Fort Bragg’s authentic, small town character. The community is defined in part by its isolated location on the magnificent coastline of Mendocino County. Its sense of place derives from its heritage as a regional center for the timber and fishing industries. As the economy evolves to a more tourism and service-based economy, the community has acknowledged the importance of maintaining the historic identify of downtown and the integrity of the residential neighborhoods, while enhancing views and access to the coastline and planning for continued growth and development.

The Community Design Element is concerned primarily with the visual quality of the City, or what residents and visitors see. The City’s appearance is essential to the quality of life in Fort Bragg. Visual quality and amenities go hand-in-hand with long-term economic development strategies, and strengthen the stability and desirability of the community. To be attractive to residents, visitors, and businesses, the City must be concerned about its appearance, physical character, and livability. Existing residential real estate values

and the desirability of businesses that depend on tourism are closely tied to the visual character of the community.

Policies and Goals from the City's General Plan include:

Policy LU-3.1 Central Business District: *Retain and enhance the small-scale, pedestrian friendly, and historic character of the Central Business District (CBD)*

Policy LU-3.6 Re-Use of Existing Buildings: *Encourage the adaptive re-use and more complete utilization of buildings in the Central Business District and other commercial districts.*

Goal LU-4 *Promote the economic vitality of the City's existing commercial areas.*

Policy LU-4.1 Formula Businesses and Big Box Retail: *Regulate the establishment of formula businesses and big box retail to ensure that their location, scale, and appearance do not detract from the economic vitality of established commercial businesses and are consistent with the small town, rural character of Fort Bragg.*

Policy LU-4.2 *Require that a fiscal and economic analysis be performed as part of the conditional use permit process for big box retail projects. The analysis shall evaluate the economic effects of the project for a minimum five-year time frame. A consultant selected by the City and paid for by the project proponent shall carry out the analysis.*

Goal C-5 *Regard the quality of life in Fort Bragg and maintaining community identity as more important than accommodating through-traffic.*

Policy C-5.1 Community Priorities for Transportation Improvements: *Place a higher priority on maintaining a sense of place and enhancing the attractiveness of the Central Business District than on efficient traffic flow and movement.*

Policy CD-1.5 Strip Development: *Discourage strip development along Main Street. Strip development is typically characterized by street frontage parking lots serving individual or strips of stores or restaurants. It differs from central business districts and shopping centers in that typically there are no provisions for pedestrian access between individual uses, the uses are only one-store deep, the buildings are arranged linearly rather than clustered, and there is no design integration among individual uses.*

Policy CD-2.3 Economic Vitality: *Continue to support the economic diversity and vitality of downtown businesses.*

Policy CD-2.5 Strengthen the Distinctive Identity of the Central Business District: *Strengthen the distinctive identity and unique sense of place of the Central Business District.*

Policy CD-3.2 Gateway Development: *Encourage a higher quality of development at the City's gateways.*

Policy CD-6.1 Protect and Preserve Buildings and Sites with Historic and Cultural Significance to the Community.

Attractive Commercial and Central Business Districts are a source of identity that when allowed to maintain a healthy mix of uses remains a source of identity for Fort Bragg and distinguishes our community from others. Many communities struggle with losing the diversity that smaller local businesses provide and the homogenous appearance resulting from the proliferation of chain formula businesses. When the same goods and services are offered in every community, our nation's communities start to look like Anywhere, USA. For communities, like Fort Bragg, which is dependent on tourism, this transition can be fiscally devastating. Most of the communities with successful formula business ordinances are small unique towns that depend on the local character to attract visitors and residents.

In October, 2020, staff conducted a non-scientific [survey of community members](#) to gauge support for or against further regulation of formula businesses. Over 1,100 responses were received and approximately two-thirds of respondents favored regulating formula businesses. Of those in favor, the largest number of respondents indicated a desire to regulate the total number and type of businesses allowed.

IMPLEMENTATION/TIMEFRAMES:

An urgency ordinance may remain in effect for only 45 days, unless it is extended by another four-fifths vote. Ten days prior to the expiration of the urgency ordinance or any extension, City Council must issue a written report describing the measure taken to alleviate the condition that led to the adoption. After notice and a hearing, a local government can extend the ordinance for either ten months and 15 days, with the option to extend it once more for an additional one-year, or once for 22 months and 15 days. Either option equates to an extension of up to two years and requires the four-fifths vote. The legislative body may rescind the urgency ordinance prior to its stated termination.

ATTACHMENTS:

1. Att. 1 – City Council Report

NOTIFICATION:

1. Economic Development Planning, **Notify Me subscriber list**
2. Tourism and Marketing, **Notify Me subscriber list**
3. Fort Bragg Downtown Businesses, **Notify Me subscriber list**



CITY OF FORT BRAGG

416 N. FRANKLIN, FORT BRAGG, CA 95437
PHONE 707/961-2823 FAX 707/961-2802

**REPORT ON MEASURES TAKEN TO ALLEVIATE THE CONDITIONS THAT LED TO
THE ADOPTION OF ORDINANCE NO. 964-2021, AN INTERIM URGENCY
ORDINANCE THAT PLACES A MORATORIUM ON THE APPROVAL OF
APPLICATIONS AND PERMITS FOR FORMULA BUSINESSES IN THE
INLAND ZONING AREA**

MEETING DATE: MAY 10, 2021
TO: GENERAL PUBLIC
**FROM: MAYOR AND CITY COUNCIL MEMBERS OF THE CITY
OF FORT BRAGG**

On April 12, 2021, the Fort Bragg City Council adopted Urgency Ordinance No. 964-2021 that placed a 45-day moratorium on the approval of applications and permits for formula businesses in the City's Inland Zoning Area. The moratorium was established to allow the City the opportunity to study and complete development of formula business regulations in order to address the unique health, safety and welfare impacts of such businesses.

Ordinance No. 964-2021 was adopted pursuant to California Government Code Section 65858 and provides that the ordinance shall expire 45 days from its date of adoption, unless the ordinance is extended by the Fort Bragg City Council after additional notice and a public hearing.

The noticed public hearing will be held on May 24, 2021, and the Fort Bragg City Council will be asked to consider extending the interim moratorium by adopting a new ordinance, as authorized by Government Code Section 65858. Staff will recommend an extension of the moratorium for a period of ten months and fifteen days, as provided for in Government Code Section 65858. However, staff anticipates that completion of and possible adoption of formula business regulations will take far less time than ten months and fifteen days. In which case, staff will request that the City Council terminate the temporary moratorium prior to its expiration date.

California Government Code Section 65858(d) requires that at least ten (10) days prior to the expiration (May 27, 2021) of the moratorium or any extension, the City Council issue a written report describing the measures taken to alleviate the conditions which led to the adoption of the ordinance. This memo serves as the required report.

Since the adoption of the moratorium, the City Manager's Office working with the City Attorney has continued to develop an ordinance to appropriately regulate formula

businesses in Fort Bragg in a manner that addresses the unique health, safety and welfare impacts of such businesses. The Planning Commission met on May 5, 2021 to review a draft ordinance that incorporates the input already provided by the Planning Commission at a series of prior meetings on: February 10, 2021; January 6, 2021; November 12, 2020 and October 14, 2020. A Planning Commission public hearing is expected for the first meeting in June 2021 and the Commission is expected to make a recommendation to the City Council to approve the formula business ordinance, to approve in a modified form or disapprove the proposed ordinance.

As set forth above, staff continues to work diligently on addressing the health, safety and welfare impacts of formula businesses but the work is not complete. Staff anticipates that the City Council will have an opportunity to review and consider a formula business ordinance before the end of the fiscal year (June 30, 2021) and it could be adopted and effective prior to the end of August 2021.

Respectfully submitted,

Mayor, Vice Mayor and City Council
Fort Bragg, California